

# Physics

For Rwanda Schools

Student's Book

Senior Two

©2020 Rwanda Basic Education Board

All rights reserved

This book is property of the Government of Rwanda.

Credit must be given to REB when the content is quoted

# Table of Contents

<i>Introduction</i> .....	<i>vii</i>
<b>Unit 1: Sources of Errors in Measurement of Physical Quantities</b> .....	<b>3</b>
1.1 Dimensions of physical quantities .....	4
1.2 Sources of errors in measurement of physical quantities .....	10
1.3 Estimating the uncertainty range of measurement .....	20
1.4 Significant figures of measurements .....	22
1.5 Rounding off numbers .....	25
1.6 Unit 1 assessment .....	26
<b>Unit 2: Quantitative Analysis of Linear Motion</b> .....	<b>31</b>
2.1 Types of Motion .....	32
2.2 Equation of uniform acceleration in one dimension .....	34
2.3 MOTION DUE TO GRAVITY .....	41
2.4 Determination of G: Use of a simple pendulum .....	46
2.5 Unit 2 assessment .....	50
<b>Unit 3: Frictional Force</b> .....	<b>53</b>
3.1 Nature of frictional force .....	54
3.2. Other resistance forces .....	59
3.3 Unit 3 assessment .....	64
<b>Unit 4: Density and Pressure in Solids and Fluids</b> .....	<b>69</b>
4.1 Pressure in solid .....	70
4.2 Pressure in liquids and gas .....	74
4.3 Atmospheric pressure .....	77
4.4 Simple pressure related applications .....	81
4.5 Common observations of pressure .....	83
4.6 Unit 4 assessment .....	86

<b>Unit 5: Measuring Liquid Pressure with a Manometer .....</b>	<b>89</b>
5.1 Pressure in liquids in equilibrium .....	90
5.2 Equilibrium of a liquid at rest .....	94
5.3 Applications of hydrostatics .....	99
5.4 Hare's apparatus .....	106
5.5 Unit 5 assessment .....	108
<b>Unit 6: Application of Pascal's principle .....</b>	<b>111</b>
6.1 Static pressure in fluids at rest.....	112
6.2 Pascal's principle and its application .....	114
6.3 Application .....	117
6.4 Unit 6 assessment .....	120
<b>Unit 7: Archimedes' Principle and Atmospheric Pressure .....</b>	<b>125</b>
7.1 Atmospheric pressure .....	126
7.2 ARCHIMEDES PRINCIPLE .....	136
7.3 APPLICATION OF ARCHIMEDES PRINCIPLE IN AIR.....	147
7.4 Unit 7 Assessment .....	149
<b>Unit 8: Work, Power and Energy .....</b>	<b>151</b>
8.1 Relating Work and Energy .....	152
8.2 Power.....	154
8.3 Categories of energy in our environment .....	155
8.5 Measure personal power.....	160
8.6 Unit 8 assessment .....	161
<b>Unit 9: Conservation of Mechanical Energy in Isolated System .....</b>	<b>163</b>
9.1 Isolated and open systems .....	164
9.2 Kinetic and potential energy of a system .....	166
9.3 Mechanical energy .....	172
9.4 Law of conservation of energy .....	172
9.5 Applications of law of conservation of mechanical energy .....	174
9.6 Unit 9 assessment .....	176



<b>Unit 10: Gas Laws' Experiments</b> .....	<b>181</b>
10.1 Introduction .....	182
10.2 Three gas laws .....	183
10.3 Ideal gas.....	192
10.4 Unit 10 assessment .....	200
<b>Unit 11: Magnetization and Demagnetization</b> .....	<b>203</b>
11.1 Structure of an atom and magnetism.....	204
11.2 MAGNETIC DOMAIN.....	207
11.3 Magnetisation and demagnetisation .....	208
11.4 SOME APPLICATIONS OF MAGNETISM .....	213
11.5 UNIT 11 ASSESSMENT.....	215
<b>Unit 12: Applications of Electrostatics</b> .....	<b>217</b>
12.1 Introduction .....	218
12.2 Static Electricity.....	219
12.3 Electric field .....	219
12.4 Electric field lines.....	222
12.5 Electric field strength due to the distribution (superposition) of electric field .....	224
12.6 Electric potential.....	225
12.7 Relationship between E and V .....	229
12.8 Charge distribution.....	230
12.9 Application of electrostatics.....	233
12.10 Van de Graff generator, electrostatic precipitator .....	242
12.11 Unit 12 assessment .....	248
<b>Unit 13: Arrangement of Resistors in an Electric Circuit</b> .....	<b>251</b>
13.1 Simple circuit elements .....	252
13.2 Arrangement of resistors .....	257
13.3 Electric potential and electric potential difference.....	263
13.4 Ohm's law .....	266
13.5 Energy and power .....	267

13.6 Magnetic effects of electric current.....	269
13.7 The Heating effect of electricity.....	271
13.8 The Chemical effect of the electric current .....	272
13.9 Unit 13 assessment .....	274
<b>Unit 14: Reflection of light in curved mirrors .....</b>	<b>281</b>
14.1 Recall reflection of light in plane mirrors.....	282
14.2 Curved mirrors.....	285
14.3 Uses of spherical mirrors .....	292
14.4 The mirror and magnification equations.....	292
14.5 Other types of curved mirrors .....	297
14.6 Unit 14 assessment .....	298
<b>Unit 15: Basic Electronic Components.....</b>	<b>301</b>
15.1 Definition of electronics .....	302
15.2 Illustration of standard symbols of some electronic components ..	303
15.3 Electronic components on a motherboard .....	307
15.4 Current–voltage characteristic.....	309
15.5 An example of electronic devices .....	315
15.6 Working principle of basic electronic devices .....	318
15.7 Unit 15 assessment .....	319
<i>Bibliography.....</i>	<i>322</i>

# Introduction

## Activity-based learning

This book is full of **activities** for you to do, as well as information for you to read.

These activities will help you learn to find out more information for yourself.

**Do all the activities.** They are the most important part of the book.

## Research

Since you have to find out information for yourself, many activities in this book call you to do research using books in the library, the internet and other sources such as newspapers and magazines.

## Icons

To guide you, each activity in the book is marked by a symbol or **icon** to show you what kind of activity it is. The icons are as follows:



Fieldwork Activity

### Fieldwork icon

Fieldwork means learning outside the classroom either in the school compound, the local area or in the learner's home area. It is suitable since it engages the learners and makes them involved in the learning process. Fieldwork can be used in all subjects.



Discussion/Vocabulary Reading

### Discussion icon

Some activities require you to discuss an issue with a partner or as part of a group. It is similar to group work, but usually does not require any writing, although some short notes can be written for remembrance..



Computer/Internet Activity

### Computer/Internet Activity icon

Some activities require you to use a computer/Internet in your computer laboratory, research or elsewhere.



Observation Activity

### Observation Activity icon

Learners are expected to observe and write down the results from activities including experiments or social settings overtime.



Practical Activity

### Practical Activity icon

The hand indicates a practical activity, such as a role play on resolving a conflict, taking part in a debate or following instructions on a map. These activities will help you to learn practical skills which you can use when you leave school.



Writing/Research Activity

### Writing Activity icon

Some activities require you to write in your exercise book or elsewhere.



Group Activity

### Group Work icon

Group work means that you are expected to discuss something in groups and report back on what your group discussed. In this way you learn from each other and how to work together as a group to address or solve a problem.

Good luck in using the book.

# **Mechanics**

Physical quantities





# Unit 1

## Sources of Errors in Measurement of Physical Quantities

### Key unit competence

By the end of this unit, I will be able to identify and explain sources of errors in measurements and report.

### My goals

By the end of this unit, I will be able to:

- state and explain types of errors in measurements.
- distinguish random and systematic errors.
- distinguish between precision and accuracy.
- explain the concept of significant figures.
- explain the error propagation in derived physical quantities.
- explain rounding off numbers.
- state the fundamental and the derived quantities and determine their dimensions.
- choose appropriate measuring instruments.
- report measured physical quantities accurately.
- reduce random and systematic errors while performing experiments.
- state correct significant figures of given measurements considering precision required.
- estimate errors on derived physical quantities.
- use dimension analysis to verify equations in physics.
- suggest ways to reduce random errors and minimise systematic errors.

## Key concepts

1. How does the precision of measurements affect the precision of scientific calculations?
2. How can one minimise the errors of measurement?



## Vocabulary

Accuracy, uncertainty, precision, random, systematic error, rounding off, significant figures.



## Reading strategy

As you read this section, mark paragraphs that contain definitions of key terms. Use the information you have learnt to write a definition of each key term in your own words.

## 1.1 Dimensions of physical quantities

### 1.1.1 Selecting an instrument to use for measuring



#### Activity 1.1: Selecting a measuring instrument

Suppose we have to measure the following quantities:

- The length and width of classroom.
- The thickness of paper.
- The diameter of a wire.
- The length of a football pitch.
- Diameter of a small sphere.
- The mass of a stone
- The mass of a feather

Discuss these questions:

1. How would you measure each quantity?
2. What would you use to measure each quantity?
3. Where else would measurements be applied in real life?



In science, **measurement** is the process of obtaining the magnitude of a quantity, such as length or mass, relative to a unit of measurement, such as a meter or a kilogram. The term can also be used to refer to the result obtained after performing the process.

The different instruments used differ in sensitivity and therefore, we must always choose one which is most suitable for measuring the quantity depending on the sensitivity required for the measurement and on the order of size of the required measurement. The sensitivity of the measuring instrument is the smallest reading which one can make with certainty using the instrument. And the accuracy of the readings made on the instrument depends on its sensitivity.

**For example,**

1. The **tape measure** is the most suitable instrument for the measurement of the length of a football field because the order of the size of the field is within the accuracy which can be obtained from a tape measure and the tape measure measures up to 50m.
2. To measure the diameter of a wire, you use a **micrometer screw gauge** because it gives the accuracy matching the order of the size of the diameter of wire.

Note that each of the instruments has its own advantages and disadvantages when used. Another important point to note is that we must read the instruments properly in order to get accurate readings. Inaccurate measurements come about if an inaccurate instrument is used or if the readings are not properly taken from the instrument.

### Checking my progress

1. What do you understand by the term measurement of physical quantity?
2. Discuss and explain the proper instrument that should be used to measure the following quantities
  - a. The mass of your physics book
  - b. The length of your desk table
  - c. The diameter of a tennis ball
  - d. The thickness of a coin

3. List at least four objects or where the following instruments should be used
  - a. Beam balance
  - b. Tape measure
  - c. A ruler
  - d. A stop watch
  - e. A vernier caliper
  - f. A micrometer screw gauge
  - g. An electronic balance

### 1.1.3 Fundamental and derived physical quantities and their dimension



#### Activity 1.2 Investigating the physical quantities

Among the following list, which are physical quantities? List the Physical quantities selecting which are fundamental and which are derived physical quantities.

Time, anger, mass, area, pressure, light, length, kilogram, density, love, volume, amount of substance, velocity, distance, kilometer.

Physical quantities are divided into two categories, those with dimensions and those that are dimensionless. Physical quantities with dimensions are classified into **Fundamental** and **derived quantities**.

Each of the seven base quantities used in the SI is regarded as having its own dimension, which is symbolically represented by a single roman capital letter.

The symbols used for the base quantities, and the symbols used to denote their dimension, are given as follows.

**Table 1.1:** Base quantities and dimensions used in the SI

Fundamental (base) quantities and their dimension		
Name	Symbol for quantity	Symbol for dimension
Length	$l$	L
Time	$t$	T
Mass	$m$	M
Electric current	$i$	I
Thermodynamic temperature	$T$	$\theta$ or K
Amount of substance (mole)	$n$	N
Luminous intensity (candela)	$I_v$	J

The dimensions of the derived quantities are written as products of powers of the dimensions of the base quantities using the equations that relate the derived quantities to the base quantities.

In general the dimension of any quantity  $Q$  is written in the form of a dimensional product,  $\dim Q = L^a M^b T^c I^d N^e J^g$  where the exponents  $a$ ,  $b$ ,  $c$ ,  $d$ ,  $e$ , and  $g$ , which are generally small integers that can be positive, negative or zero, are called the **dimensional exponents**.

#### Example:

1. Length may have units of meters, centimetres, hectometres, millimeters or micrometers; but any length always has a dimension of L, independent of what units are arbitrarily chosen to measure it.
2. The physical quantity, speed, may be measured in units of metres per second; but regardless of the units used, speed is always a length divided by a time, so we say that the dimensions of speed are length divided by time, or simply  $\frac{L}{T}$  or  $LT^{-1}$
3. The dimensions of area are  $L^2$  since area can always be calculated as a length times a length.

There are some derived quantities  $Q$  for which the defining equation is such that all of the dimensional exponents in the expression for the dimension of  $Q$  are zero. For instance quantity that is defined as the ratio

of two quantities of the same kind. Such quantities are described as being dimensionless, or alternatively as being of dimension one.

The unit of a physical quantity and its dimension are related, but not identical concepts. The units of a physical quantity are defined by convention and related to some standard;

**Example:**

The dimension for relative density (RD) or specific gravity (SG) is zero as:

$$SG = \frac{\text{density of a substance (} r_{sub} \text{)}}{\text{density of a standard substance (} r_{s.sub} \text{)}}$$

Hence, this makes the relative density quantity to be dimensionless.

$$SG = \frac{M^1L^{-3}}{M^1L^{-3}} = M^1L^{-3}M^{-1}L^3 = M^0L^0$$

### 1.1.4 Dimensional analysis



#### Activity 1.3 Investigating about dimensional analysis

Using a dictionary or search internet, find and discuss on dimensional analysis of physical quantity. Discuss your findings

It is important to realize that it only makes sense to add the same sort of quantities, e.g. area may be added to area but area may not be added to temperature! These considerations lead to a powerful method to analyze scientific equations called dimensional analysis. One should note that while units are arbitrarily chosen (an alien civilization will not use seconds or weeks), dimensions represent fundamental quantities such as time.

Dimensional analysis is the analysis of the relationships between different physical quantities by identifying their base quantities (such as length, mass, time and electric charge) and units of measure.

The fact that an equation must be homogenous enables predictions to be made about the way in which physical quantities are related to each other.

## Checking my progress

- Calculate the dimensions of the following quantities
  - Volume
  - Speed
  - Acceleration
  - Densit
- Pick out the units that have a different dimension to the other three.
  - $kgm^2s^{-2}$
  - $kg^2ms^{-2}$
  - $gmm^2s^{-2}$
  - $mgcm^2s^{-2}$
- Newton's law of gravity states that the gravitational force between two masses,  $m_1$  and  $m_2$ , separated by a distance  $r$  is given by  $F = G \frac{m_1 m_2}{r^2}$ . What are the dimensions of  $G$ ?
  - $L^3 M^{(-1)} T^{(-2)}$
  - $M^2 L^{(-2)}$
  - $M L T^{-2}$
  - $M^{-1} L^{-3} T^2$
- The coefficient of thermal expansion,  $\alpha$  of a metal bar whose length expands by  $\Delta l$ , when its temperature increases by  $\Delta T$  is given by  $\Delta l = a l \Delta T$ . What are the dimensions of  $\alpha$ ?
  - $K^{-1}$
  - $L^2 T^{-1}$
  - $L^2 T^{-1}$
  - $L^{-2} K^{-1}$

## 1.2 Sources of errors in measurement of physical quantities



### Activity 1.4: Investigating sources of errors

Take the case of measuring the length and width of an A4 paper.

**Material:**

- A4 paper
- Ruler

**Procedure:**

Measure the sizes (width and length) of the provided paper using the ruler and record your results.

Discovery:

1. Compare your results with those of other learners.
2. You may be having same outcomes, but some are having different outcome. Why there might be some differences while you are using same ruler and measuring same paper?
3. What do you think brings those differences and suggest some factors that may cause those differences?

A **measurement** is an observation that has a numerical value and unit.

In order for a measurement to be useful, a standard measurement must be used.

**Standard measurement** is an exact quantity that people agree on to be used for comparison or as a reference to measure other quantities.

We have three kinds of standards:

- International standard,
- Regional standard and
- National standard.

The science of measurement is called **metrology**. It has three branches to know: Legal metrology, Industrial metrology and Material testing.

## 1.2.1 Types of errors



### Activity 1.5: Investigating types of errors

#### Materials:

- Tape measure
- Table

#### Procedure:

- Using the tape-measure, measure the length of your table and record the result.
- Repeat the same measurement several times and record the results.
- Compare your findings.

#### Questions:

1. Are your results the same?
2. (If not) What may have caused the differences?
3. Where do you think errors come from?

Experimental errors are inevitable. In absolutely every scientific measurement there is a degree of uncertainty (experimental error) we usually cannot eliminate. Understanding errors and their implications is the only key to correctly estimating and minimising them.

The experimental error can be defined as: “the difference between the observed value and the true value” (Merriam-Webster Dictionary).

The uncertainties in the measurement of a physical quantity (errors) in experimental science can be separated into two categories: **random** and **systematic**.

#### ● **Random errors**

**Random errors** fluctuate from one measurement to another. They may be due to: poor instrument sensitivity, random noise, random external disturbances, and statistical fluctuations (due to data sampling or counting).

A random error arises in any measurement, usually when the observer has to estimate the last figure possibly with an instrument that lacks sensitivity. Random errors are small for a good experimenter and taking the mean of a number of separate measurements reduces them in all cases.

- **Systematic errors**

Systematic errors usually shift measurements in a systematic way. They are not necessarily built into instruments. Systematic errors can be at least minimised by instrument calibration and appropriate use of equipment.

A systematic error may be due to an incorrectly calibrated instrument, for example a ruler or an ammeter. Repeating the measurement does not reduce or eliminate the error and the existence of the error may not be detected until the final result is calculated and checked, say by a different experimental method. If the systematic error is small a measurement is accurate.

There are two main causes of error: **human** and **instrument**.

- **Human error** can be due to mistakes (misreading 22.5cm as 23.0cm) or random differences (the same person getting slightly different readings of the same measurement on different occasions). For example:

- the experimenter might consistently read an instrument incorrectly, or might let knowledge of the expected value of a result influence the measurements (Bias of the experimenter)
- incorrect measuring technique: For example, one might make an incorrect scale reading because of parallax error (reading a scale at an angle)
- failure to interpret the printed scale correctly.

- **Instrument errors** can be systematic and predictable (a clock running fast or a metal ruler getting longer with a rise in temperature). The judgment of uncertainty in a measurement is called the absolute uncertainty, or sometimes the raw error. For example:

- errors in the calibration of the measuring instruments.
- zero error (the pointer does not read exactly zero when no measurement is being made).
- the instrument is wrongly adjusted.

The goal of a good experiment is to reduce the systematic errors to a value smaller than the random errors. For example a meter stick should have been manufactured such that the millimeter markings are located much more accurately than one millimeter.



## 1.2.2 Accuracy and Precision

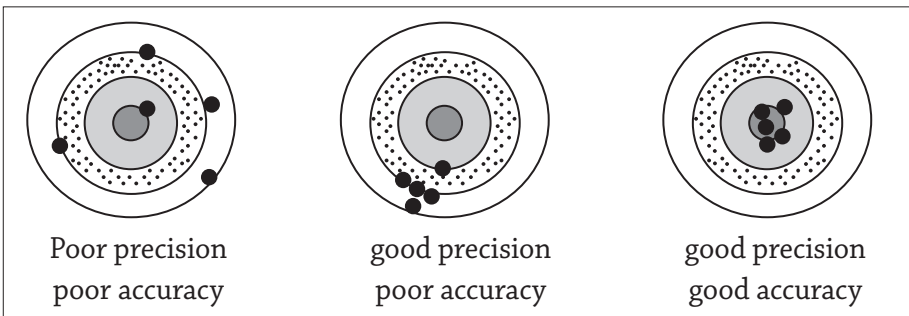
The terms accuracy and precision are often misused.

- Experimental **precision** means the degree of exactness of the experiment or how well the result has been obtained. Precision does not make reference to the true value; it is just a quality attribute to the repeatability or reproducibility of the measurement.
- **Accuracy** refers to correctness and means how close the result is to the true value. Accuracy depends on how well the systematic errors are compensated. Precision depends on how well random errors are reduced.

Accuracy is the degree of veracity (“how close to true”) while precision is the degree of reproducibility (“how close to exact”).

Accuracy and precision must be taken into account simultaneously. All measurements have a degree of uncertainty: no measurement can be perfect!

A measurement system can be accurate but not precise, precise but not accurate, neither, or both. For example, if an experiment contains a systematic error, then increasing the sample size generally increases precision but does not improve accuracy. Eliminating the systematic error improves accuracy but does not change precision.



**Fig. 1.1:** Accuracy and precision

A measurement system is called **valid** if it is both **accurate** and **precise**.

**Uncertainty** depends on both the accuracy and precision of the measurement instrument. The lower the accuracy and precision of an instrument, the larger the measurement uncertainty is. Often, the uncertainty of a measurement is found by repeating the measurement enough times to get a good estimate of the standard deviation of the values.

### 1.2.3 Calculations of errors

When combining measurements in a calculation, the uncertainty in the final result is larger than the uncertainty in the individual measurements. This is called **propagation of uncertainty** and is one of the challenges of experimental physics.

There are simple rules that can provide a reasonable estimate of the uncertainty in a calculated result:

#### A. ABSOLUTE AND RELATIVE ERRORS (UNCERTAINTIES)

When reading a scale it is standard practice to allow an error of one half of a scale division (depending on the scale being used and the operator's eyesight). But as well as the reading being judged there is also the zero setting to be judged and this also has an uncertainty of half of a scale division. So for most instruments the total error for a measurement is  $\pm 1$  scale division.

*Take the case of a standard measurement sometimes called true value and a measured value  $l$ :*

• **Absolute error** denoted as  $\Delta l_a$  is given by the relation  $\Delta l_a = |l_o - l|$

where the vertical bars means the absolute value and the  $l_o \neq 0$

• **Relative error** denoted as  $\Delta l_r$  is given by the relation

$$\Delta l_r = \frac{|l_o - l|}{l_o}$$

• **Percentage error** denoted as  $\Delta l_{\%}$  is given by the relation

$$\Delta l_{\%} = \frac{|l_o - l|}{l_o} \times 100\% = \frac{\Delta l_a}{l_o} \times 100\%$$

**Example 1.** If the measurement is 5.2 cm and the uncertainty is 0.1 cm, the percent uncertainty is:

**Solution:** Given  $l_o = 5.2 \text{ cm}$  and the uncertainty (absolute error)  $\Delta l_a = 0.1 \text{ cm}$ ,

Hence the percentage error

$$\begin{aligned} \Delta l_{\%} &= \frac{|l_o - l|}{l_o} \times 100\% = \frac{\Delta l_a}{l_o} \times 100\% \\ &= \frac{0.1 \text{ cm}}{5.2 \text{ cm}} \times 100\% = 2\% \end{aligned}$$

**Example 2.** You measure the length of the object to be 10.2cm, with an absolute error of 0.2cm; the length the object will then be reported as  $(10.2 \pm 0.2)\text{cm}$ .

The percentage error is then given by:

$$\frac{\Delta L}{L} \times 100 = \frac{0.2}{10.2} \times 100 = 1.961\%$$

In experimental measurements, the uncertainty in a measurement value is not specified explicitly. In such cases, the uncertainty is generally estimated to be half units of the last digit specified. For example, if a length is given as 5.2cm, the uncertainty is estimated to be 0.5mm.

## B. OPERATIONS WITH ERRORS

### 1. Addition and Subtraction of errors

Let consider two quantities

$$x_m = x \pm \Delta x \quad \text{and} \quad y_m = y \pm \Delta y$$

- For the addition (Sum)

$$\begin{aligned} S_m &= s \pm \Delta s = x_m + y_m \\ &= (x \pm \Delta x) + (y \pm \Delta y) \\ &= (x + y) \pm (\Delta x + \Delta y) \end{aligned}$$

$$\text{Hence, } s = x + y \quad \text{while} \quad \Delta s = \Delta x + \Delta y$$

- For subtraction (difference)

$$\begin{aligned} D_m &= d \pm \Delta d = x_m - y_m \\ &= (x \pm \Delta x) - (y \pm \Delta y) \\ &= (x - y) \pm (\Delta x + \Delta y) \end{aligned}$$

$$\text{Hence, } d = x - y \quad \text{while} \quad \Delta d = \Delta x + \Delta y$$

When measurements with uncertainties are added or subtracted, add the *absolute uncertainties* of either addition or subtraction errors in order to obtain the absolute uncertainty of the measurement.

### Example 1:

You measure a zero value (starting point) of a meter stick as;  $x = (0.10 \pm 0.05)\text{cm}$ . You measure the position of the end of an object as being  $y = (10.34 \pm 0.05)\text{cm}$ . Calculate the length of the object

**Solution**

The length of the object is just the difference: The uncertainty is given by the rule for addition/subtraction

$$\begin{aligned}l &= y - x \\ &= 10.34 \text{ cm} - 0.10 \text{ cm} \\ &= 10.24 \text{ cm}\end{aligned}$$

$$\begin{aligned}\Delta l &= \Delta x + \Delta y \\ &= 0.05 \text{ cm} + 0.05 \text{ cm} \\ &= 0.10 \text{ cm}\end{aligned}$$

The length of the object is then

$$l_m = l + \Delta l = (10.24 \pm 0.10) \text{ cm}$$

**Example 2:**

Uwimana measured the temperature of water in their water pot in the morning and she recorded it to be  $(27.6 \pm 0.5)^\circ\text{C}$ . After school she again measured the temperature of the water and this time it was  $(99.2 \pm 0.5)^\circ\text{C}$ .

The Change in Temperature is calculated as follows:

$$\begin{aligned}\Delta T &= T_2 - T_1 = (99.2 \pm 0.5)^\circ\text{C} - (27.6 \pm 0.5)^\circ\text{C} = (71.6 \pm 1.0)^\circ\text{C} \\ &= 71.6^\circ\text{C} \pm 1.4\%\end{aligned}$$

**2. Multiplication and Division****Multiplication and Division by a constant**

Multiplication and Division by a constant C

Given quantity  $x_m = x \pm \Delta x$  and a constant C.

Then:

- For multiplication by a constant c

$$c \times x_m = c \times (x \pm \Delta x) = c \times x \pm c \times \Delta x$$

- For Division by a constant c:  $\frac{x_m}{c} = \frac{x \pm \Delta x}{c} = \frac{x}{c} \pm \frac{\Delta x}{c}$

Multiplication and division by a constant C just multiplies or divides the absolute uncertainty by the same constant, C.

**NOTE:** The relative error,  $\frac{\Delta z}{z}$ , is not affected!

### Example

The radius of a circle is given by  $r = \frac{d}{2}$ , where  $d$  is the diameter of the circle.

If you measure  $d \pm \Delta d = (1.2 \pm 0.05)$  cm, the uncertainty in the radius  $r$  is given by the rule for division by a constant:

$$\begin{aligned} r \pm \Delta r &= \frac{d}{2} = \frac{(1.20 \pm 0.05) \text{ cm}}{2} \\ &= (0.60 \pm 0.025) \text{ cm} \end{aligned}$$

### 3. Multiplication and Division of $x$ and $y$

Let consider two quantities with uncertainty

$$x_m = x \pm \Delta x \quad \text{and} \quad y_m = y \pm \Delta y$$

- For multiplication

$$\begin{aligned} z &= x_m \times y_m = (x \pm \Delta x) \times (y \pm \Delta y) \\ &= x \times y \pm \left( \frac{\Delta x}{x} + \frac{\Delta y}{y} \right) \end{aligned}$$

- For division

$$\frac{x_m}{y_m} = \frac{(x \pm \Delta x)}{(y \pm \Delta y)} = \frac{x}{y} \pm \left( \frac{\Delta x}{x} + \frac{\Delta y}{y} \right)$$

For the area of a rectangle is given by  $A = l \times w$ , where  $l$  and  $w$  are the length and width of the rectangle. You measure  $l \pm \Delta l = 2.4 \pm 0.05 \text{ cm}$  and  $w \pm \Delta w = 0.8 \pm 0.05 \text{ cm}$ .

The area  $A = l \times w = (2.4) \times (0.8) = 1.9 \text{ cm}^2$ , to one of decimals.

The uncertainty in the area  $\Delta A$  is given by the rule for multiplication, where  $x = l$ ,  $y = w$  and  $z = A$ :

$$\frac{\Delta A}{A} = \frac{\Delta l}{l} + \frac{\Delta w}{w}$$

First we need to find the relative errors  $\frac{\Delta l}{l}$  and  $\frac{\Delta w}{w}$ :

$$\frac{\Delta l}{l} = \frac{0.05}{2.4} = 0.021$$

$$\frac{\Delta w}{w} = \frac{0.05}{0.8} = 0.063$$

The relative error in A is just the sum of the relative errors in l and w:

$$\frac{\Delta A}{A} = \frac{\Delta l}{l} + \frac{\Delta w}{w} = 0.021 + 0.063 = 0.084$$

The absolute and relative errors in A are reported as

$$\Delta A = A \frac{\Delta A}{A} = 1.9 \times 0.084 = 0.160 \text{cm}^2, \text{ to one place of decimal.}$$

$$= 0.2 \text{cm}^2$$

$$A \pm \Delta A = (1.9 \pm 0.2) \text{cm}^2$$

We round the absolute uncertainty to 1 sig fig and match precisions in our final answer; the relative uncertainty is rounded to the same sig figs as the answer in the absolute case.

**Example 1.** A rectangular plate has a length of  $(21.3 \pm 0.05) \text{cm}$  and a width of  $(9.80 \pm 0.05) \text{cm}$ . Find the area of the plate and the uncertainty in the calculated area.

**Answer:**  $A = lw = (21.3)(9.80) = 208.74 \text{cm}^2$

$$\begin{aligned} \frac{\Delta A}{A} &= \frac{\Delta l}{l} + \frac{\Delta w}{w} \\ &= \frac{0.05}{21.3} + \frac{0.05}{9.8} \\ &= 0.002 + 0.005 \\ &= 0.007 \end{aligned}$$

$$\begin{aligned} \Delta A &= A \times 0.007 \\ &= 208.74 \times 0.007 \\ &= 1.461 \text{ cm}^2 \end{aligned}$$

$$\therefore A \pm \Delta A = (208.74 \pm 1.461) \text{ cm}^2$$

To one place of decimals

$$A \pm \Delta A = (208.7 \pm 1.5) \text{cm}^2$$

**Example 2.** Fraction of used capacity is given by  $F = \frac{V_{used}}{V_{tot}}$ , where  $V_{used}$  and  $V_{tot}$  are the used and total volumes of a container.

You found  $V_{used} \pm \Delta V_{used} = 0.9 \pm 0.1 \text{cm}^3$  and

$$V_{tot} \pm \Delta V_{tot} = 1.7 \pm 0.1 \text{cm}^3.$$

The fraction of used capacity is  $F = \frac{V_{used}}{V_{tot}} = \frac{0.9}{1.7} = 0.529$

The uncertainty in the fraction of used capacity,  $\Delta F$  is given by the rule for division,

$$\frac{\Delta F}{F} = \frac{\Delta V_{used}}{V_{used}} + \frac{\Delta V_{tot}}{V_{tot}}$$

First we need to find the relative errors  $\frac{\Delta V_{used}}{V_{used}}$  and  $\frac{\Delta V_{tot}}{V_{tot}}$ :

$$\frac{\Delta V_{used}}{V_{used}} = \frac{0.1}{0.9} = 0.111 \text{ and } \frac{\Delta V_{tot}}{V_{tot}} = \frac{0.1}{1.7} = 0.059$$

The relative error in  $F$  is just the sum of the relative errors in  $V_{used}$  and  $V_{tot}$ :

$$\frac{\Delta F}{F} = \frac{\Delta V_{used}}{V_{used}} + \frac{\Delta V_{tot}}{V_{tot}} = 0.111 + 0.059 = 0.1700$$

The absolute and relative errors in  $F$  are reported as:

$$\Delta F = F \frac{\Delta F}{F} = 0.529 \times 0.17 = 0.089895 \text{ cm}^3$$

$$F \pm \Delta F = (0.53 \pm 0.09) \text{ cm}^3$$

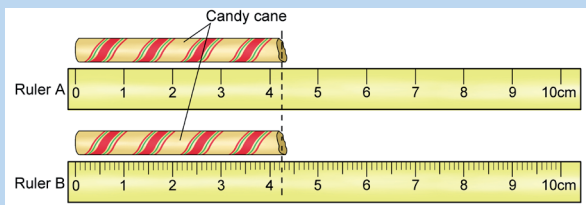
We round the absolute uncertainty to 1 sig fig and match precisions in our final answer; the relative uncertainty is rounded to the same sig figs as the answer in the absolute case.

## Checking my progress

1. Which measurements are consistent with the metric rulers shown in Figure below?

(a) Ruler A: 2 cm, 2.0 cm, 2.05 cm, 2.5 cm, 2.50 cm

(b) Ruler B: 3.0 cm, 3.3 cm, 3.33 cm, 3.35 cm, 3.50 cm



2. Given that the radius of a circular disc was measured to be  $r = (1.25 \pm 0.05) \text{ cm}$ , calculate

- Its circumference
- Its area

3. The width and length of a rectangle were measured to be  $w = (2.3 \pm 0.5) \text{ cm}$  and  $l = (7.3 \pm 0.1) \text{ cm}$  respectively. Calculate its
  - a. Perimeter
  - b. Area
4. Discuss the difference between accuracy and precision
5. When do we say that a measurement is valid?

### 1.3 Estimating the uncertainty range of measurement

Repeated measurements allow you to not only obtain a better idea of the actual value, but also enable you to characterise the uncertainty of your measurement. Below are a number of quantities that are very useful in data analysis. The value obtained from a particular measurement is repeated  $N$  times. Often times in lab  $N$  is small, usually no more than 5 to 10. In this case we use the formulae below:

**Table 1.3: Uncertainty calculation**

<b>Mean (<math>x_{avg}</math>)</b>	The average of all values of $x$ (the “best” value of $x$ )	$x_{avg} = \frac{x_1 + x_2 + \dots + x_N}{N}$
<b>Range (R)</b> <b>Uncertainty in a measurement (<math>\Delta x</math>)</b>	The “spread” of the data set. This is the difference between the maximum and minimum value of $x$ .  Uncertainty in a single measurement of $x$ . You determine this uncertainty by making multiple measurements. You know from your data that $x$ lies somewhere between $x_{max}$ and $x_{min}$ .	$R = X_{max} - X_{min}$  $\Delta x = \frac{R}{2} = \frac{x_{max} - x_{min}}{2}$
<b>Uncertainty in the mean (<math>\Delta x_{avg}</math>)</b>	Uncertainty in the mean value of $x$ . The actual value of $x$ will be somewhere in a neighborhood around $x_{avg}$ . This neighborhood of values is the uncertainty in the mean.	$\Delta x_{avg} = \frac{\Delta x}{\sqrt{N}} = \frac{R}{2\sqrt{N}}$
<b>Measured value (<math>x_m</math>)</b>	The final reported value of a measurement of $x$ contains both the average value and the uncertainty in the mean.	$x_m = x_{avg} \pm \Delta x_{avg}$



The average value becomes **more and more precise** as the number of measurements  $N$  increases. Although the **uncertainty** of any single measurement is always, the **uncertainty in the mean**, it becomes smaller (by a factor of ) as more measurements are made.

### Example:

Given the table below, use these measurements recorded in the two data sets and calculate the mean, the range, the uncertainty measurement, the uncertainty in the mean and the measured value.

**Table 1.4:** Measurement data

Measurement	Data set 1 (cm)	Data set 2 (cm)
$x_1$	72	80
$x_2$	77	81
$x_3$	82	81
$x_4$	85	81
$x_5$	88	82

For Data Set 1, to find the best value, you calculate the mean (i.e. average value):

$$\begin{aligned} X_{avg} &= \frac{x_1 + x_2 + x_3 + x_4 + x_5}{5} \\ &= \frac{72 \text{ cm} + 77 \text{ cm} + 82 \text{ cm} + 85 \text{ cm} + 88 \text{ cm}}{5} \\ &= 80.8 \text{ cm} \end{aligned}$$

The **range**, **uncertainty** and **uncertainty** in the mean for Data Set 1 are then:

$$R = 88 \text{ cm} - 72 \text{ cm} = 16 \text{ cm}$$

$$\Delta x = \frac{R}{2} = \frac{16 \text{ cm}}{2} = 8 \text{ cm}$$

$$\Delta x_{avg} = \frac{\Delta x}{2\sqrt{N}} = \frac{R}{2\sqrt{N}} = \frac{16 \text{ cm}}{2\sqrt{5}} = 3.6 \text{ cm}$$

We report the measured lengths  $X_m$  as:  $X_m = (80.8 \pm 3.6) \text{ cm}$

For Data Set 2 yields the same average but has a much smaller range.

## Checking my progress

Use the following data sets and estimate the measured value for each case. Calculate the mean, the range, the uncertainty measurement, the uncertainty in the mean and the measured value

### 1. Length in cm

$x_1$	$x_2$	$x_3$	$x_4$	$x_5$	$x_6$
23.53	24.10	24.65	25.32	25.48	25.87

### 2. Temperature in °C

$T_1$	$T_2$	$T_3$	$T_4$	$T_5$	$T_6$	$T_7$
37.1	36.8	36.5	35.6	37.5	36.9	34.9

## 1.4 Significant figures of measurements

No quantity can be measured exactly. All measurements are approximations. A digit that was actually measured is called a **significant digit**. Significant digits may be shown on measuring devices (rulers, meters, etc.) as tick marks or displayed digits, although you can't always be sure. The number of significant digits is called **precision**. It tells us how precise a measurement is—how close to exact. For example if you say that the length of an object is 0.428 m, you imply an uncertainty of about 0.001m.

### 1.4.1 The rules for identifying significant digits

The rules for identifying significant digits when writing or interpreting numbers are as follows:

- All non-zero digits are considered significant. For example, 91 has two significant figures (9 and 1), while 123.45 has five significant figures (1, 2, 3, 4 and 5).
- Zeros appearing anywhere between two non-zero digits (trapped zeroes) are significant. Example: 101.12 has five significant figures: 1, 0, 1, 1 and 2.
- Leading zeros (zeroes that precede all non-zero digits) are not significant. For example, 0.00052 has two significant figures: 5 and 2. Leading zeroes are always placeholders (never significant). For example, the three zeroes in the quantity 0.002 m are just

placeholders to show where the decimal point goes. They were not measured. We could write this length as 2 mm and the zeroes would disappear.

- Trailing zeros (zeros that are at the right end of a number) in a number containing a decimal point are significant. For example, 12.2300 has six significant figures: 1, 2, 2, 3, 0 and 0. The number 0.000122300 still has only six significant figures (the zeros before the 1 are not significant). In addition, 120.00 has five significant figures. This convention clarifies the precision of such numbers; for example, if a result accurate to four decimal places is given as 12.23 then it might be understood that only two decimal places of accuracy are available. Stating the result as 12.2300 makes it clear that it is accurate to four decimal places.

Generally, the same rules apply to numbers expressed in scientific notation. For example, 0.00012 (two significant figures) becomes  $1.2 \times 10^{-4}$ , and 0.000122300 (six significant figures) becomes  $1.22300 \times 10^{-4}$ .

In particular, the potential ambiguity about the significance of trailing zeros is eliminated. For example, 1300 to four significant figures is written as  $1.300 \times 10^3$ , while 1300 to two significant figures is written as  $1.3 \times 10^3$ . Numbers are often rounded off to make them easier to read. It's easier for someone to compare (say) 18% to 36% than to compare 18.148% to 35.922%.

**Note:**

Zeros at the end of a number but to the left of a decimal, in this handbook will be treated as not significant for example 1 000 m may contain from one to four significant figures, depending on precision of the measurement, but in this hand book it will be assumed that measurements like this have one significant figure.

- Do not confuse significant figures with decimal places. For example, consider measurements yielding 2.46 s, 24.6 s and 0.002 46 s. These have two, one, and five decimal places, but all have three significant figures.
- If a number is written with no decimal point, assume infinite accuracy; for example, 12 means 12.0000....

## Checking my progress

- State the number of significant digits in the following measurements:
 

(a) 12,345 cm	(b) 0.123 g
(c) 0.5 mL	(d) 102.0 s
- State the number of significant digits in the following measurements:
 

(a) 0.025 cm	(b) 0.2050 g
(c) 25.0 mL	(d) 2500 s

### 1.4.2 Special rules of calculation with significant figures

The final answer should not be more precise than the least precise measurement in your data. For example, though your calculator gives an answer to nine digits, do not give this number of digits in your final answer.

**Example:** Perform these calculations, following the rules for significant figures

- Addition or subtraction:** the final answer should have the same number of digits to the right of the decimal as the measurement with the smallest number of digits to the right of the decimal.

$$97.3 + 5.85 = 103.15 \cong 103.2$$

$$8.82\text{m} + 4\text{m} = 12.82 \cong 13\text{m}$$

( $\cong$  Means, approximately equal to)

- Multiplication or division:** the final answer has the same number of figures as the measurement having the smallest number of significant figures.

$$123 \times 5.35 = 658.05 = 658$$

$$11.2 \times 6.8 = 77 \text{ (6.8 has the least number of significant figures, namely two)}$$

$$2035\text{cm} \times 12.5\text{m} = 254.375\text{m}^2 = 2.54 \times 10^4 \text{cm}^2 \text{ (it is better to make the conversion to the same units before doing any more arithmetic)}$$

## 1.5 Rounding off numbers



### Activity 1.6: Rounding off a number

Using your ruler; measure the width ( $w$ ) of your Physics notebook and express your result in metres. Measure it other six times and note the results in metres.

$w_1$	$w_2$	$w_3$	$w_4$	$w_5$	$w_6$	$w_7$

#### Questions:

1. Calculate the average of your measurement
2. Round off your result to 2 decimal places

- Round off your result to 2 decimal places

The concept of significant figures is often used in connection with rounding. For example, the population of a city might only be known to the nearest thousand and be stated as 52,000, while the population of a country might only be known to the nearest million and be stated as 52,000,000. When we compute with measured figures, we often round off numbers so that they will show the precision or accuracy that is appropriate.

In rounding off, we drop digits or replace digits with zeros to make numerals easier to use and interpret. Instead of saying 45,125 people attended the football match last Sunday; we would probably round the value to 45,000 people. When we replace digits with zeros by rounding off, the zeros are not significant. In rounding off a number, the digits dropped must be replaced by 'place holding' zeros. The following rules will be found useful when rounding off figures:

- If the first of the digits to be dropped (reading from left to right) is 1, 2, 3 or 4, simply replace all dropped digits with the appropriate number of zeros. For example, 57,384 rounded off to the nearest thousands becomes 57,000.
- If the first of the digits to be dropped (reading from left to right) is 6, 7, 8 or 9, increase the preceding digit by 1. For e.g., 5,383 rounded off to the nearest hundred becomes 5,400.

- If only one digit is to be dropped and this digit is 5, increase the preceding digit by 1 if it is odd, and leave it unchanged if it is even. Thus, if 685 is to be rounded off to the nearest tens it becomes 680, while 635 rounded off to the nearest tens becomes 640.
- If a decimal fraction is rounded off, zeros should not replace the digits that are to the right of the decimal, because zeros to the right of a decimal are significant. For example, 73.2 rounded off to one significant figure becomes 70 and not 70.0 to the nearest tens.

### Checking my progress

1. Round off the following numbers to three significant digits:  
(a) 22.250                      (b) 0.34548  
(c) 0.072038                  (d) 12,267
2. Round off the following numbers to four significant digits:  
(a) 12.514748                  (b) 0.6015261  
(c) 192.49032                  (d) 14652.832

## 1.6 Unit 1 assessment

1. The learners listed below measured the density of a piece of lead three times. The density of lead is actually  $11.34 \text{ g/cm}^3$ . Below are their results;
  - a) Rachel:  $11.32 \text{ g/cm}^3$ ,  $11.35 \text{ g/cm}^3$ ,  $11.33 \text{ g/cm}^3$
  - b) Daniel:  $11.43 \text{ g/cm}^3$ ,  $11.44 \text{ g/cm}^3$ ,  $11.42 \text{ g/cm}^3$
  - c) Leah:  $11.55 \text{ g/cm}^3$ ,  $11.34 \text{ g/cm}^3$ ,  $11.04 \text{ g/cm}^3$ 
    - (i) Whose results were accurate?
    - (ii) Whose were precise?
    - (iii) Whose measurements were both accurate and precise?

2. Arrange the following measurements in order of precision beginning with the most precise: 17.04cm; 843 cm; 0.006cm; 342.0cm.
3. Round off to;
- the nearest unit: 6.8; 10.5; 801.625,
  - the nearest tenth 5.83; 480.625; 0.234; 0.285; 6.58; 36.092,
  - the nearest hundredth: 3.632; 812.097; 0.71
  - the nearest thousandth: 0.2827; 0.0066.
  - the nearest tens: 56; 44; 17; 656,
  - the nearest hundreds: 219; 256; 71,550; 930.7,
  - the nearest thousands: 890; 1600; 10 500; 13 856; 5420.5
4. Round off the following measurement so that all have the same degree of accuracy: 468.5m; 0.00708m; 3.467m; 56.93m; 3.004m
5. Perform the following operations, rounding off each answer to the proper degree of accuracy:
- $6.574 + 34.57 =$
  - $23.12 \times 34.9 =$
  - $5.2 - 5.7 =$
  - $625/15 =$
  - $\text{Sqrt}(5625) =$
6. Round off the numbers below to the shown number of significant figures in the brackets:
- |                 |               |
|-----------------|---------------|
| f) 245 086 (4); | h) 8 465 (3); |
| g) 406.50 (3)   | i) 84.25 (2); |
7. Multiple choice
- A. The number of significant digits in 0.0006032 is
- |      |      |      |      |
|------|------|------|------|
| a) 8 | b) 7 | c) 4 | d) 2 |
|------|------|------|------|
- B. The length of a body is measured as 3.51m. If the accuracy is 0.01 m, then the percentage error in the measurement is;
- |           |            |
|-----------|------------|
| a) 351 %  | b) 1 %     |
| c) 0.28 % | d) 0.035 % |
- C. The dimensional formula for gravitational constant is;
- |                         |                      |
|-------------------------|----------------------|
| a) $M^1L^3T^{-2}$       | b) $M^{-1}L^3T^{-2}$ |
| c) $M^{-1}L^{-3}T^{-2}$ | d) $M^1L^{-3}T^2$    |

- D. The velocity of a body is expressed as  $v = (x/t) + yt$ . The dimensional formula for  $x$  is;
- a)  $ML^0T^0$                       b)  $M^0LT^0$   
 c)  $M^0L^0T$                       d)  $MLT^0$
8. What is the absolute error if the central value is 120s and the relative error is 5%?
- a) 1.2s                                  b) 5s                      c) 6s
9. Which measurement is most precise?
- b)  $T = 7.5 \text{ s} \pm 0.2\text{s}$   
 c)  $L = 10.0\text{m} \pm 0.2\text{m}$   
 d)  $D = 5.6\text{cm} \pm 4\%$
10. A bulb thermometer recorded an indoor temperature reading of  $21^\circ\text{C}$ . A digital thermometer in the same room gave a reading of  $20.7^\circ\text{C}$ . Which device is more precise? Explain.
11. Suppose that two quantities  $A$  and  $B$  have different dimensions. Determine which of the following arithmetic operations *could* be physically meaningful:
- a)  $A + B$                                   c)  $A - B$   
 b)  $\frac{A}{B}$     d)  $A \times B$
12. If an equation is dimensionally correct, does this mean that the equation must be true? If an equation is not dimensionally correct, does this mean that the equation cannot be true?
13. Is it possible to add a vector quantity to a scalar quantity? Explain.
14. If  $\mathbf{A} = \mathbf{B}$ , what can you conclude about the components of  $\mathbf{A}$  and  $\mathbf{B}$ ?



# **Mechanics**

## Motion





# Unit 2

## Quantitative Analysis of Linear Motion

### Key unit competence

By the end of this unit I should be able to interpret and solve problems related to linear Motion.

### My goals

By the end of this unit, I will be able to:

- Describe and define linear motion and list examples of linear motion.
- Explain the difference between instantaneous and average speed, velocity and acceleration.
- Derive the equations of linear motion.
- Describe and explain the acceleration of a free falling body near the earth's surface and describe the motion of a free falling body.
- Describe the conditions applicable to equations of uniformly accelerated motion.
- Distinguish between linear motions from other motions.
- Solve problems related to linear motion.
- Apply the scientific techniques in solving problems related to the motion of bodies moving against gravitational acceleration

## Key concepts

1. What is needed to describe motion completely?
2. When is an object in motion?
3. Why is distance and displacement different?
4. How do you add and subtract displacements?
5. How are instantaneous speed and average speed different?



## Vocabulary

Motion, kinematics, trajectory, position, displacement, speed, average speed, acceleration, translational motion, average acceleration, accelerated motion.



## Reading strategy

Study the Newton's laws of motion and relate them to the situations and common problems in motion of bodies.

## 2.1 Types of Motion

### 2.1.1 Definition and types of linear motion



### Activity 2.1: Investigating about types of motion.

Take the case of car moving from your school to town.

Questions:

1. Describe different parts of the road from your school to town?
2. If a part of the road is straight, which types of motion the car will undergo?
3. If a part of the road is curved, which types of motion the car will undergo?
4. Describe the motion of hands of a clock.

When a body moves in a straight line, then we say that it is executing **linear motion**. When it moves without rotating, it is said to have translational motion. A car moving down a highway is an example of translational motion.

When a body moves in a straight line, then the linear motion is called **rectilinear motion**.



**Fig. 2.1:** *Rwanda Air plane running to take off from air port.*

**Example:** An athlete running along a straight track is said to be in rectilinear motion.

When a body moves along a curved path then the motion is called **curvilinear motion**. E.g., a planet revolving around its parent star.



**Fig. 2.2:** *A boat moving in curvilinear motion in a river*

Other motion problems examine the effects of forces such as gravity on an object's rectilinear motion. One common example involves shooting a projectile up into the air.

## Checking my progress

1. Describe using typical examples the following types of motion
  - a. Rectilinear motion
  - b. Curvilinear motion
  - c. Rotatory motion
2. Which types of motion a bird takes when it is flying?
3. Which type of motion a wheel of car takes when the car is moving?
4. State and describe other types of motion you know.

## 2.2 Equation of uniform acceleration in one dimension

### 2.2.1 Acceleration



### Activity 2.2: Comparing the velocity change of a marble

#### Materials:

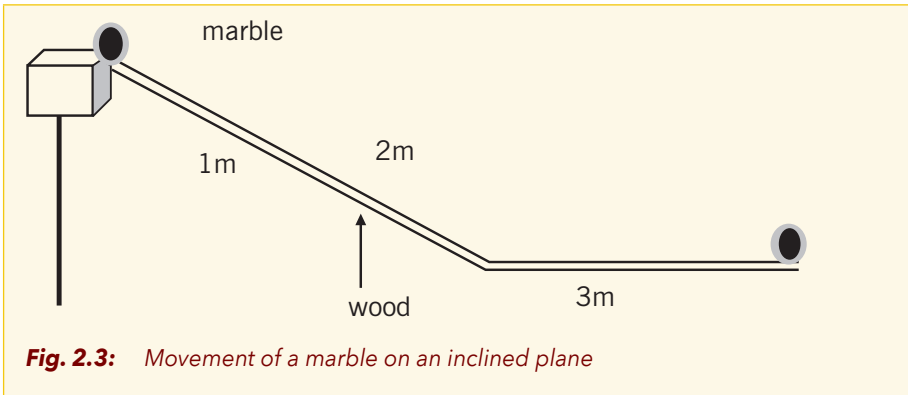
A marble, Stop watch; an inclined rail with marked strips 1m each

#### Procedure:

- Arrange the incline plane as shown in Figure 2.3.
- Allow a marble to roll from rest down the rail.
- Time the marble as it moves the first 1 m.
- Time the marble as it moves through the first 2 m.
- Time the marble as it moves the 3 m.

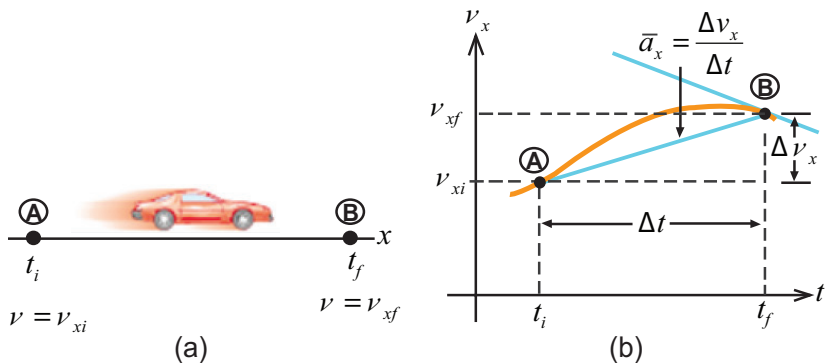
#### Questions:

1. What is the average velocity as the marble moves the first 1m?
2. What is the average velocity of the marble as it moves the second 1 m?
3. What is the average velocity of the marble as it moves the third 1 m?
4. Where is the marble moving fastest?
5. Is the velocity increasing or decreasing?



When the velocity of a body is changing, the body is said to be accelerating. **Acceleration** is defined as the rate of change of velocity with time.

$a = \frac{\Delta v}{\Delta t} = \frac{v_f - v_i}{t_f - t_i}$  where  $v_f$  is the final velocity at time  $t_f$  and  $v_i$  is the initial velocity at time  $t_i$ .



**Fig. 2.4:** A car, modeled as a particle, moving along the  $x$  axis

In Fig. 2.4 we have (a) A car, modeled as a particle, moving along the  $x$  axis from (A) to (B) has velocity  $v_{xi}$  at  $t = t_i$  and velocity  $v_{xf}$  at  $t = t_f$ . (b) Velocity–time graph for the particle moving in a straight line. The slope of the blue straight line connecting (A) and (B) is the average acceleration in the time interval  $\Delta t = t_f - t_i$ .

### Types of acceleration

- **Uniform acceleration:** When acceleration is constant both in direction and in magnitude, the object is said to be undergoing uniformly accelerated motion.

• **Positive acceleration:** A body whose velocity is increasing is said to be accelerating or have positive acceleration.

• **Negative acceleration:** A decrease in velocity or slowing down indicates a retardation or deceleration or negative acceleration.

• **Zero acceleration:** When a body's velocity is neither increasing nor decreasing it is said to have zero acceleration. During uniform rectilinear motion, a body has zero acceleration.

Considering a moving body changing its velocity from initial velocity  $u$  to its final velocity  $v$  or vice versa in a given time  $t$  we have the relations

Acceleration:

$$a = \frac{\Delta v}{\Delta t} = \frac{v-u}{t} \quad \text{considering } \Delta t = t - t_0 = t$$

Deceleration or retardation: 
$$d = \frac{\Delta v}{\Delta t} = \frac{u-v}{t}$$

**Example 1.** If an object gains a velocity of  $10\text{m/s}$  in  $5\text{s}$ , its average

acceleration is 
$$a = \frac{\text{change in velocity}}{\text{time taken}}$$

$$= \frac{10\text{m/s}}{5\text{s}}$$

$$= 2\text{ms}^{-2}$$

**Example 2.** A motor car is uniformly retarded and brought to rest from a speed of  $108\text{ km/h}$  in  $15\text{ s}$ . Find its acceleration.

**Answer:**

Given:  $u = 108\text{ km/h} = 30\text{ m/s}$  and  $v = 0\text{ m/s}$

$$a = \frac{\Delta v}{\Delta t} = \frac{v-u}{\Delta t} = \frac{0-30}{15} = -2\text{m/s}^2$$

The minus sign here simply means that the car is accelerating in the opposite direction to its initial velocity.

## 2.2.2 Velocity with constant acceleration

By rearranging the equation for acceleration, we can find a value for the final velocity

$$a = \frac{\Delta v}{\Delta t} = \frac{v-u}{\Delta t}$$

This gives the equation 
$$v = at + u$$



Do not confuse acceleration and velocity. Acceleration tells us how fast the velocity changes, whereas velocity tells us how fast the position changes.

### 2.2.3 Displacement with constant acceleration

For an object moving with constant acceleration, the average velocity is equal to the average of the initial velocity and final velocity;

$$\bar{v} = \frac{v+u}{2}$$

To find an expression for the displacement ( $S$ ) from initial position to its final position  $S$  in terms of the initial and final velocity, we can set the expressions for average velocity equal to each other:

$$\bar{v} = \frac{\Delta S}{\Delta t} = \frac{v+u}{2} \text{ (where } \Delta S = S - S_0 \text{ and } \Delta t = t - t_0 \text{)}$$

Multiplying both sides of the equation by  $\Delta t = t$  where  $t_0 = 0$  leaves us with an expression for the displacement of any object moving with constant acceleration:

$$\Delta S = \left(\frac{v+u}{2}\right)t$$

Substituting  $v = at + u$  into  $\Delta S = \left(\frac{v+u}{2}\right)t$  gives:

$$\Delta S = \frac{1}{2}at^2 + ut \Leftrightarrow S - S_0 = \frac{1}{2}at^2 + ut$$

$$\boxed{S = \frac{1}{2}at^2 + ut + S_0}$$

When the  $S_0 = 0$  or when it is not given, then

$$\boxed{S = \frac{1}{2}at^2 + ut}$$

**Example 1.** A race car reaches a speed of 42m/s. It immediately then begins a uniform negative acceleration, using its braking system, and comes to rest 5.5s later. Find how far the car moves while stopping.

**Answer:**

Use the equation for displacement;

$$\begin{aligned}\Delta S &= \left(\frac{v+u}{2}\right)t = \frac{0+42}{2} \times 5.5\text{m} \\ &= 115.5\text{m}\end{aligned}$$

**Example 2.** A plane starting at rest at one end of a runway undergoes a constant acceleration of  $4.8\text{m/s}^2$  for 15s before takeoff. What is its speed at takeoff? How long must the runway be for the plane to be able to take off?

**Answer**

Use the equation for the velocity of a constantly accelerated object:

$$\begin{aligned}v &= u + a\Delta t \\ &= 0 + 4.8\text{m/s}^2 \times 15\text{s} \\ &= 72\text{m/s}\end{aligned}$$

Use the equation for the displacement:

$$\begin{aligned}\Delta S &= u\Delta t + \frac{1}{2}a(\Delta t)^2 \\ &= \left[0 + \frac{1}{2} \times 4.8 \times (15)^2\right]\text{m} \\ &= 540\text{m}\end{aligned}$$

Additional relations between displacement, velocity and acceleration can be derived.

We have

$$v = at + u \quad \text{hence, } t = \frac{v-u}{a}$$

Then replacing the value of time  $t$  in

$$S = \frac{1}{2}at^2 + ut + S_0 \quad \text{we get}$$

$$S = \frac{1}{2}a\left(\frac{v-u}{a}\right)^2 + ut + S_0$$

$$\begin{aligned}S - S_0 &= \frac{1}{2}a \frac{v^2 - 2uv + u^2}{a^2} + u\left(\frac{v-u}{a}\right) \\ &= \frac{v^2 - 2uv + u^2 + 2uv - 2u^2}{2a} \\ &= \frac{v^2 - u^2}{2a}\end{aligned}$$

$$\text{Hence, } \boxed{v^2 - u^2 = 2a(S - S_0)}$$

When  $S_0 = 0$  we get

$$v^2 - u^2 = 2aS \quad \text{or} \quad v^2 = u^2 + 2aS$$

This relation is useful when time is not known explicitly

If we know any three of  $u$ ,  $v$ ,  $a$ ,  $S$  and  $t$  the others can be found from these equations.

$$a = \frac{\Delta v}{\Delta t} = \frac{v-u}{t} \quad (1) \text{ Equation for acceleration}$$

$$v = at + u \quad (2) \text{ Equation for velocity}$$

$$S = \frac{1}{2}at^2 + ut + S_0 \quad (3) \text{ Equation for distance / displacement when time } t \text{ is known}$$

$$v^2 - u^2 = 2a(S - S_0) \text{ or } (4) \text{ Equation for } v, u, a \text{ or } S \text{ when time } t \text{ is not known}$$

$$v^2 = u^2 + 2a(S - S_0)$$

These formulae only apply to cases of particles moving under constant acceleration. If this condition does not apply to the situation under consideration, then you cannot use these formulae.

### Sign Convention

Before we start applying these formulae, let us introduce a sign convention. Since we are working in one dimension, there are only two directions we need to worry about. For instance, if we consider motion in a horizontal direction, the only two directions are left and right. Likewise, if we consider motion in a vertical direction, the only two directions are up and down.

Mathematically, we can denote the two directions with a sign. The convention that must be used for quantities associated with the body with respective motion below:

#### Horizontal Motion

Right is (+).

Left is (-).

#### Vertical Motion

Up is (+).

Down is (-).

For example: If a rocket is moving up at the speed of  $10,000\text{m/s}$ , we can just write the rocket's velocity as  $10,000\text{m/s}$ . If the rocket had been moving downward, then the sign in front of the  $10,000\text{m/s}$  would have been negative, (-).

**Example 1.** What is the velocity of an object, at rest, if it experiences a constant acceleration of  $10\text{m/s}^2$  to the right after a period of 3s?

**Answer:**

The initial velocity of the object is because we stated that it was initially at rest.

The constant acceleration is  $a = 10\text{m/s}^2$  to the right. The time that the object accelerates is  $t = 3\text{s}$ .

Using velocity formula  $v = v_o + at$  gives:

$$v = 0\text{m/s} + (10\text{m/s}^2 \times 3\text{s}) = 30\text{m/s}$$

The object will move at a velocity of  $30\text{m/s}$  to the right after undergoing a constant acceleration of  $10\text{m/s}^2$  to the right for  $3\text{s}$ .

**Example 2.** As a bus comes to stop, it slows from  $9.00\text{m/s}$  to  $0.00\text{m/s}$  in  $360\text{s}$ . Find the average acceleration of the bus.

**Answer:**

$$v = v_o - at$$

$$0 = 9\text{m/s} - a \times 360$$

$$a \times 360\text{s} = 9\text{m/s}$$

$$a = \frac{9\text{m/s}}{360\text{s}}$$

$$a = \frac{1}{40} \text{ m/s}^2$$

$$= 0.025\text{m/s}^2$$

**Check my progress**

- 1) What is the average speed of a cheetah that runs  $65\text{ m}$  in  $3.0$  seconds?
- 2) A bicycle travels  $15\text{ km}$  in  $30$  minutes. What is its average speed?
- 3) A jet on an aircraft carrier can be launched from  $0$  to  $50\text{ m/s}$  in  $2.0$  seconds

What is the acceleration of the jet?

- 4) A skateboarder starting from rest accelerates down a ramp at  $4.0\text{ m/s}^2$  for  $4.0\text{s}$ . What is the final speed of the skateboarder?
- 5) How much time does a car with an acceleration of  $4.0\text{ m/s}^2$  take to go from  $10\text{ m/s}$  to  $30\text{ m/s}$ ?
- 6) Starting from rest, a car undergoes a constant acceleration of  $6.0\text{ m/s}^2$ . How far will the car travel in the first second?

## 2.3 MOTION DUE TO GRAVITY

### 2.3.1 Acceleration due to gravity and free fall motion



#### Activity 2.3: Investigating about motion under gravity

##### Materials:

- A stop clock.
- Five stones of different masses between 0.5kg → 5kg.
- A long wooden pole.

##### Procedure:

- Measure out a distance of 2m from the floor of your laboratory but against a pole.
- From the smallest stone to the biggest stone, drop the stones one by one. Using the stop clock, find out how long each stone takes to reach the floor.
- Repeat this three times for each stone and find out the average time for each stone.
- Determine the average speed of each stone after falling for 2m.

##### Questions:

1. What causes the stones to fall down?
2. How fast did the different stones fall?
3. Take a paper and a stone. Drop them at the same time from the same height. Which one comes to the ground first?

The falling bodies undergo motion with uniform acceleration i.e. as they fall, their velocity increases by equal steps in equal time intervals. This acceleration, which the falling bodies have, is called **acceleration due to gravity** and is denoted by the letter, 'g'. The acceleration due to gravity is the same for all objects, provided where there is very limited or no air resistance.

The kind of fall where the bodies fall under the influence of gravity only regardless of its initial motion is called **free fall motion**. In free fall, the only outside force acting on the falling body is the pull of gravity with different masses.

The presence of air affects the motion of falling bodies partly through buoyancy and partly through air resistance. Thus two different objects falling in air from the same height will not, in general, reach the ground at exactly the same time. Because air resistance increases with velocity, eventually a falling body reaches a *terminal velocity* that depends on its mass, size, and shape, and it cannot fall any faster than that.

**Example 1.** Let's say you are standing next to a cliff and decide to drop a ball. What is the ball's velocity after 4s?

**Answer:**

$$\begin{aligned} \text{From } v &= u - gt \\ v &= u - gt \\ &= 0 - 9.81\text{m/s} \times 4\text{s} \\ &= -39.32\text{m/s} \end{aligned}$$

The negative sign shows this – the motion is downwards.

**Example 2.** A stone dropped from the top of a building takes 6s to reach the ground below.

- What is the height of the building?
- How far will the stone fall during the fifth second of its falling?

**Answer:**

$$\begin{aligned} \text{a) Using the equation } h &= ut - \frac{gt^2}{2} \\ h &= 0 - \frac{10\text{m/s}^2 \times (6\text{s})^2}{2} \\ &= \frac{-360\text{ m}}{2} \\ &= -180\text{m} \end{aligned}$$

The negative sign indicates that the height of the building was calculated from the point of release of the stone downwards to the bottom of the building.

- The fifth second begins immediately after the end of the fourth second and stops at the end of the fifth second.

$$\begin{aligned} \text{For } t = 4\text{s}, h_1 &= ut - \frac{gt^2}{2} \\ &= 0 - \frac{10 \times (4)^2}{2} \\ &= -80\text{m} \end{aligned}$$

$$\begin{aligned}
 \text{for } t = 5s, h_2 &= ut - \frac{gt^2}{2} \\
 &= 0 - \frac{10 \times (5)^2 m}{2} \\
 &= -125m
 \end{aligned}$$

The height the stone falls through in the fifth second is then given by:

$$\begin{aligned}
 \Delta h &= h_2 - h_1 \\
 &= -125 - (-80) \\
 &= -45m.
 \end{aligned}$$

The negative sign indicates that measurement was from up to down, following the motion of the stone.

### 2.3.2 EQUATIONS OF MOTION UNDER GRAVITY

- For a falling body (Free fall motion)

$$\begin{cases} h = \frac{1}{2}gt^2 + ut \\ v = gt + u \\ v^2 - u^2 = 2gh \end{cases} \quad (+g)$$

Where the motion is accelerated motion as the object falls down

- For an object thrown upward

$$\begin{cases} h = -\frac{1}{2}gt^2 + ut \\ v = -gt + u \\ v^2 - u^2 = -2gh \end{cases} \quad (-g)$$

As the motion is decelerated due to the decrease in velocity.

### 2.3.3 MAXIMUM HEIGHT

When an object is thrown vertically upward, it ends coming back due to the gravitation attraction. This means that at the top velocity is 0

$$v = -gt + u = 0 \text{ m/s}$$

Hence:

$$-gt + u = 0 \Leftrightarrow t = \frac{u}{g}$$

$$\text{Hence } \boxed{t_{\max} = \frac{u}{g}}$$

$t_{\max}$  time that a body takes to reach the maximum height

Total time for an object thrown upward, go and back to the ground is given by the relation

To reach maximum height ( $h_{\max}$ ) it takes a time period equal

to  $t_{\max} = \frac{u}{g}$ . Replacing the value of  $t_{\max}$  in the relation:

$$h = -\frac{1}{2}gt^2 + ut \quad \text{We get:}$$

$$h = -\frac{1}{2}gt^2 + ut \quad (\text{with } t = t_{\max} = \frac{u}{g})$$

$$\begin{aligned} h_{\max} &= -\frac{1}{2}gt_{\max}^2 + ut_{\max} \\ &= -\frac{1}{2}g\left(\frac{u}{g}\right)^2 + u\left(\frac{u}{g}\right) \\ &= \frac{u^2}{2g} \end{aligned}$$

$$\text{Hence, } \boxed{h_{\max} = \frac{u^2}{2g}}$$

**Example 1.** A man fires a stone out of a slingshot directly upwards. The stone has an initial velocity of  $15\text{m/s}$ . How long will it take for the stone to return to the level he fired it at?

**Answer:**

Using the equation

$$\text{we have: } h = ut - \frac{gt^2}{2}$$

$$0 = 15t - \frac{10t^2}{2}$$

$$\frac{10t^2}{2} = 15t$$



$$\frac{10t}{2} = 15s$$

$$10t = 30s$$

$$t = 3s$$

**Example 2.** A falling body travels 68m in the last second of its free motion: Assuming that the body started from rest, determine how long it took to reach the ground and the altitude from which the body fell.

**Answer:**

A convenient axis is one with origin at the point of dropping and pointing downward. Let  $t_1$  be the time one second before hitting the ground and  $h_1$  the corresponding distance travelled. Let  $t_2$  be the time to hit the ground and  $h_2$  the corresponding distance travelled. (Use  $g = 9.8 \text{ m/s}^2$ )

Then  $t_2 - t_1 = 1 \text{ s}$  and  $h_2 - h_1 = 68\text{m}$ .

From the equation  $h = ut - \frac{gt^2}{2}$

$$\text{then } h_1 = 0 - \frac{9.8 \times t_1^2}{2}$$

$$= -4.9t_1^2$$

$$\text{Similarly } h_2 = -4.9t_2^2$$

$$\text{But } h_2 - h_1 = 68\text{m}$$

$$\text{and } t_2 = t_1 + 1$$

$$\text{Then } -4.9(t_1 + 1)^2 + 4.9t_1^2 = 68$$

$$-4.9t_1^2 - 9.8t_1 - 4.9 = -4.9t_1^2 + 68$$

$$9.8t_1 = 68 - 4.9$$

$$9.8t_1 = 63.1$$

$$t_1 = 6.48$$

$$\text{using } t_2 = t_1 + 1$$

$$t_2 = 6.48 + 1$$

$$= 7.48 \text{ s}$$

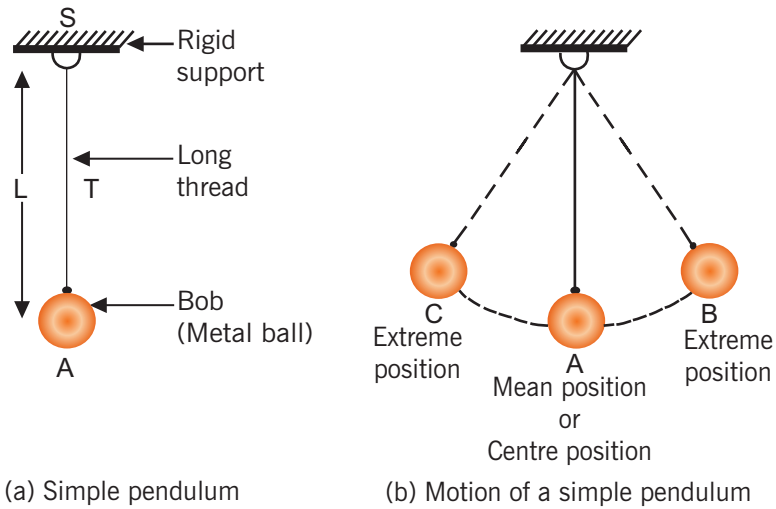
The altitude is then  $h_2 = -4.9\text{m/s}^2 (7.48\text{s})^2 = 274.16\text{m}$

## Checking my progress

1. A stone is thrown vertically upwards with an initial velocity of 14m/s. Neglecting air resistance, find:
  - a) The maximum height reached;
  - b) The time taken before it reaches the ground. (acceleration due to the gravity is  $9.8\text{m/s}^2$ )
2. A person throws a ball upward into the air with an initial velocity of 15.0 m/s. Calculate:
  - a) How high it goes.
  - b) How much time it takes for the ball to reach the maximum height.
  - c) How long the ball is in the air before it comes back to his hand.
  - d) The velocity of the ball when it returns to the thrower's hand.
  - e) At what time, the ball passes a point 8.00m above the thrower's hand. We are not concerned here with the throwing action, but only with the motion of the ball after it leaves the thrower's hand.
3. A stone is dropped from a balloon that is descending at a uniform rate of 0.2m/s when it is 1000m from the ground.
  - a) Calculate the velocity and position of the stone after 10s and the time it takes the stone to hit the ground.
  - b) Solve the same problem as for the case of a balloon rising at a velocity of 0.1m/s.

## 2.4 Determination of G: Use of a simple pendulum

Many things in nature swing in a periodic motion. That is, they vibrate. One such example is a **simple pendulum**. If we suspend a mass at the end of a piece of string, and we allow the mass to swing up and down along the vertical axis, we have a simple pendulum. Here, the to and fro motion represents a periodic motion used in times past to control the motion of clocks.

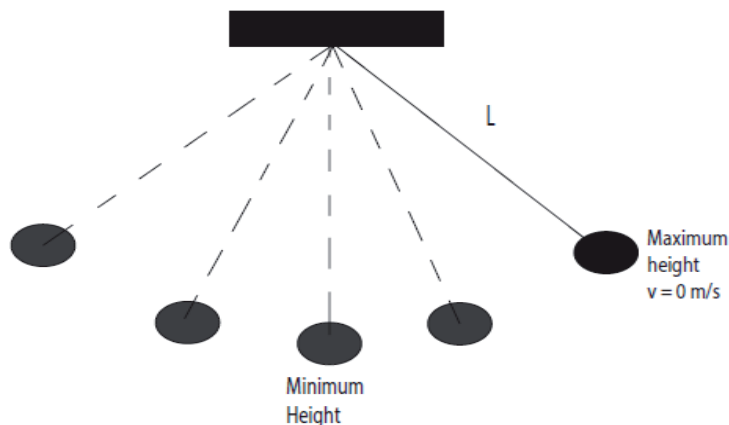


**Fig. 2.5:** A Pendulum bob

Such oscillatory motion is called **simple harmonic motion**. It was Galileo who first observed that the time a pendulum takes to swing back and forth through small angles depends only on:

The **length of the pendulum**, the **time of this to and fro motion**, called the **period**, and does not depend on the mass of the pendulum. Another factor involved in the period of motion is, **the acceleration due to gravity ( $g$ )**, which on the earth is  $9.8\text{m/s}^2$  at the equator.

A long pendulum has a greater period than a shorter pendulum.



**Fig. 2.6:** A Pendulum bob swinging

With the assumption of small angles of projection, the frequency and period of the pendulum are independent of the initial angular displacement.

All simple pendulums have the same period regardless of their initial angle (and regardless of their masses of the bobs).

The period,  $T$  for a simple pendulum does not depend on the mass or the initial angular displacement, but depends only on the length,  $L$  of the string and the value of the gravitational field strength,  $g$ ;

$$T = 2\pi \sqrt{\frac{L}{g}}$$



### 2.4.1 checking my progress

Referring to the above concept, use the formula given below and try to answer the questions.

#### Materials:

- Strings
- A pendulum bob (mass)
- Masses of 10, 20, 30, 40 and 50 gms
- Stop watch
- A paper and a pencil
- Metre rule
- Retort stand

#### Procedure:

1. The period,  $T$  of a simple pendulum (measured in seconds) is given by the formula:

$$T = 2\pi \sqrt{\frac{L}{g}} \quad (1)$$

$$T = \frac{\text{Time for 30 oscillations}}{30 \text{ oscillations}} \quad (2)$$

2. Using equation (1) to solve for “ $g$ ”,  $L$  is the length of the pendulum (measured in meters) and  $g$  is the acceleration due to gravity (measured in meters/sec<sup>2</sup>). Now with a bit of algebraic rearranging, we may solve Eq. (1) for the acceleration due to gravity  $g$ . (You should derive this result on your own).

$$g = 4\pi^2 \frac{L}{T^2} \quad (3)$$

3. Measure the length of the pendulum from the clamp of the retort stand to the middle of the pendulum bob. Record the length of the pendulum in a table. Attach a mass of 10 gms to the end of the given string. Clip the other end of the string to a rigidly fixed retort stand.
4. Set the pendulum in motion until it completes 30 to and fro oscillations, and for 4 sets of dings, record this time and determine the period.
5. You will make a total of eight measurements for  $g$  using two different masses at four different values for the length,  $L$ .

**Note:**  $\pi = 3.14$ ,  $4\pi^2 = 39.44$

L (meters)	Mass	Time for 30 oscillations	Period T (seconds)	$T^2$	$g = 39.44L/T^2$

**Average value of  $g$  = \_\_\_\_\_**

### Questions:

1. From your data what effect does changing the mass have on the period?
2. Would you conclude that Galileo was correct in his observation that the period of a simple pendulum depends only on the length of the pendulum?
3. On the moon, the acceleration due to gravity is one-sixth that of earth.

What effect, if any, would this have on the period of a pendulum of length,  $L$ ?

How would the period of the pendulum on the moon differ from an equivalent one on earth?

## 2.5 Unit 2 assessment

1. If the velocity of a particle is non-zero, can its acceleration be zero? Explain.
2. If the velocity of a particle is zero, can its acceleration be nonzero? Explain.
3. Two cars are moving in the same direction in parallel lanes along a highway. At some instant, the velocity of car, A exceeds the velocity of car, B. Does this mean that if the acceleration of the car reduces, A is greater than that of car, B? Explain.
4. You are standing on top of a cliff and you decide to throw a stone upward at a speed of  $15\text{m/s}$ . After  $4.0\text{s}$ , you see the stone hit the base of the cliff. How far down is the base of the cliff? In addition, what is the velocity of the stone when it reaches the base of the cliff?
5. A feather and a coin are released from the same height at the same time. Which one reaches the ground first? Explain why they do not reach the ground at the same time.
6. How long will it take a car to accelerate from  $10\text{m/s}$  to  $35\text{m/s}$  at a constant acceleration of  $5\text{m/s}^2$  in a straight line.
7. Imagine a ball that is thrown upward with a velocity of  $5\text{m/s}$ . If the ball experiences a downward constant acceleration of  $10\text{m/s}^2$ , how long will it take for its velocity to reach  $25\text{m/s}$  downward?
8. Assume there is a jet plane initially moving to the right at  $10\text{m/s}$ . Furthermore, then it accelerates for  $90\text{s}$  and ends up with a speed of  $20\text{m/s}$  but moving to the left. Assuming the acceleration was constant, what is the constant acceleration the jet plane undergoes?
9. A car accelerates along a straight road from rest to  $75\text{km/h}$  in  $5.0\text{s}$ . What is the magnitude of its average acceleration?
10. An car with an initial speed of  $4.3\text{m/s}$  accelerates at the rate of  $3.0\text{m/s}^2$ . Find the final speed and the displacement after  $5.0\text{s}$ .
11. A ball is thrown upwards with an initial velocity  $u$ . After  $3\text{s}$  the velocity of the ball upwards is determined to be  $10\text{m/s}$ . Calculate the value of the initial velocity  $u$ . Use  $g = 10\text{m/s}^2$ .
12. A car with an initial speed of  $23.7\text{km/h}$  accelerates at a uniform rate of  $0.92\text{m/s}^2$  for  $3.6\text{s}$ . Find the final speed and the displacement of the car during this time.

# **Mechanics**

## Forces







# Unit 3

## Frictional Force

### Key unit competence

---

By the end of this unit I should be able to explain the effects of friction and its importance in life.

### My goals

---

By the end of this unit, I will be able to:

- Explain the nature and effects of frictional force.
- Discuss advantages and disadvantages of frictional forces.
- Measure static and dynamic coefficients of friction.
- Describe technological applications of frictional force.
- Identify factors affecting frictional force and Methods of reducing friction.
- Solve problems on frictional force.

### Key concepts

---

1. What is needed to describe frictional force?
2. Which factors cause friction?
3. Discuss different types of friction?
4. How is friction advantageous in real life?
5. What are the disadvantages of friction in real life?
6. How can you overcome friction?
7. How can you increase friction?



## Vocabulary

Frictional force, resistance force, weight, roughness, smoothness, coefficient of friction, viscosity, air resistance.



## Reading strategy

As you read this section, re-read the paragraphs that contain definitions of key terms. Use all the information you have learnt to write a definition of each key term in your own words. Then practice more examples and activities to help you in performing your assessment.

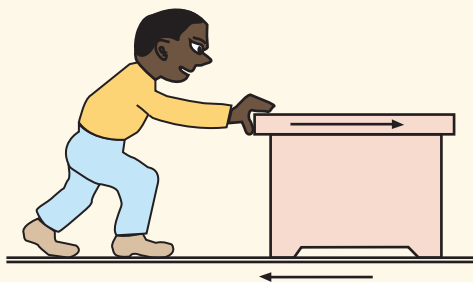
### 3.1 Nature of frictional force

#### 3.1.1 Definition of friction force



### Activity 3.1: Experiencing friction while pushing a desk

Carry out the following activity and discuss your observation.

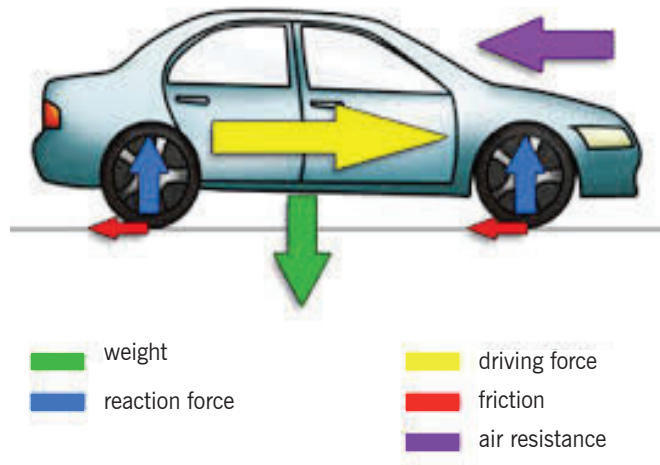


**Fig. 3.1:** Pushing a box

Push a heavy object (such as your desk), gradually till it moves at a steady speed. Carefully describe your observation.

#### Questions:

1. Was it easy to make the desk move?
2. What do you think was hindering the desk to move easily?
3. If you think there was a force, which type of force?
4. Describe the effects of that force.



**Fig. 3.2:** Frictional force on car tyres

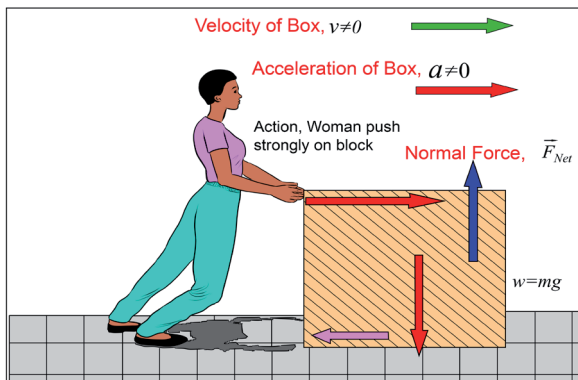
**Friction is the force that opposes the motion of an object as it moves across a surface or as it makes an effort to move across it.**

For example, if a book slides across the surface of a desk, then frictional force will act in the opposite direction to motion.

### 3.1.2 Types of frictional forces

Friction is a surface force that opposes motion. The frictional force is directly related to the normal force which acts to keep two solid objects separated at the point of contact. There are two broad classifications of frictional forces: static friction and kinetic friction.

- a) Static friction is a force between two bodies in physical contact that are not in motion (i.e at rest). The bodies are stationary.



Mathematically this force is given by:

$$F_{fs} = \mu_s F_N$$

where  $\mu_s$  is the coefficient of static friction and  $F_N$  is the normal force where the body's weight is acting

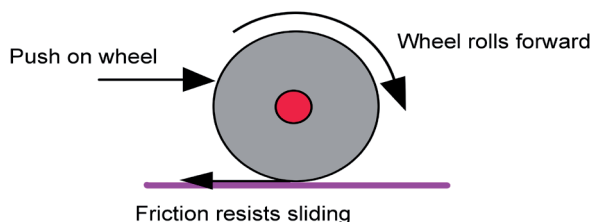
where  $\mu_s$  is the coefficient of static friction.

- b) Kinetic friction or sliding friction is the frictional force between bodies that are in physical contact but are in motion relative to one another.

Mathematically:  $F_{kf} = \mu_k F_N$

where  $\mu_k$  is the coefficient of kinetic friction and  $F_N$  is the normal reaction.

Rolling friction or rolling drag, is the force resisting the motion when a body (such as a ball, tire, or wheel) rolls on a surface. The coefficient of rolling resistance is generally much smaller than the coefficient of sliding friction.



The general equation for rolling friction is:

$$F_r = \mu_r F_N$$

where:  $F_r$  is the resistive force of rolling friction,  $\mu_r$  is the coefficient of rolling friction for the two surfaces and  $F_N$  is the normal force pushing the wheel to the surface

### 3.1.3 The laws of solids friction

Experimental results on solid friction are summarised in the laws of friction which state:

- The frictional force between two surfaces opposes their relative motion.
- The frictional force is independent of the area of contact of given surfaces when the normal reaction is constant.

- The limiting frictional force is proportional to the normal reaction for the case of static friction.
- The frictional force is proportional to the normal reaction for the case of kinetic (dynamic) friction, and is independent of the relative velocity of the surfaces.

The symbol  $\mu$  represents the **coefficient of sliding friction** between the two surfaces and depends on the roughness of the surfaces e.g. for wood on wood  $\mu = 0.4$ , for steel on steel  $\mu = 0.2$

**Experimentally for most surface interfaces, the coefficient of kinetic friction is less than the coefficient of static friction as shown in the following table.**

**Table 3.1: Coefficients of Friction**

	$\mu_s$	$\mu_k$
Steel on steel	0.74	0.57
Aluminum on steel	0.61	0.47
Copper on steel	0.53	0.36
Rubber on concrete	1.0	0.8
Wood on wood	0.25 – 0.5	0.2
Glass on glass	0.94	0.4
Ice on ice	0.1	0.03

### 3.1.4 Advantages and disadvantages of friction

- **Advantages**

Friction is very important because it **enables us to move**. If there was no friction, our feet would slip, just as they do on smooth surface. Friction also **enables us to write, to make fire, the brakes of cars or bicycles use friction to slow them down**.

- **Disadvantages**

It is also a nuisance because **it wears the soles of our shoes and the car tyres, causes the unnecessary heat and undesirable noise, lowers efficiency of machines**. In a machine such as a bicycle, **friction hinders the wheels from turning freely**. This is also true in other machines like cars, lorries, buses. This means that they use more fuel in order to move because they have to overcome friction.

### 3.1.5 Factors affecting friction and how to reduce it

Experiments show that the force of friction between two surfaces in contact depends on:

- The nature of the surfaces. Rough surfaces give more friction than smooth ones. So if we want to make a machine in which very little friction acts, we make the surfaces smooth.
- The force pressing the surfaces together. The bigger this force is, the greater the force of friction.
- The type of shape also, where some shapes meet less resistance than others. The shapes which meet the least resistance are said to be **streamlined**.
- The size of frictional force also depends the speed of the moving object.

The frictional force or resistance met by an object through air is always much less than it experiences when moving through a liquid.

The moving machine parts are always oiled or greased in order to reduce friction. This helps the moving parts to slip more easily over each other. The liquid is usually oil, which we refer to as a lubricant (reduce friction by separating two contacting surfaces with an intermediate layer of softer material). And we call the effect **lubrication**. The 2<sup>nd</sup> method involves reducing the roughness of the surfaces in contact; we can also use a ball or roller bearings.

#### Checking my progress

1. Friction is a force that acts in an \_\_\_\_\_ direction of movement.
  - a. similar
  - b. opposite
  - c. parallel
  - d. west
2. Which type of friction occurs when solid surfaces slide over each other?
  - a. rolling
  - b. static
  - c. sliding
  - d. fluid

3. Which type of friction occurs when an object rolls over or rotates on a surface?
  - a. sliding
  - b. static
  - c. fluid
  - d. rolling
4. Which type of friction occurs when objects are not moving?
  - a. static
  - b. sliding
  - c. fluid
  - d. rolling
5. Discuss and explain the advantages and disadvantages of frictional force.

## 3.2. Other resistance forces

### 3.2.1 Tensional forces



#### Activity 3.2: Investigation of tension force

##### Material:

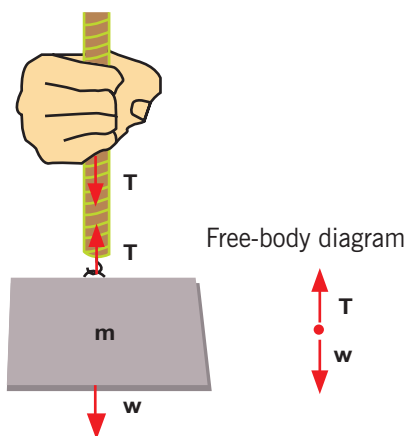
- Rope
- Six stones of different masses
- Spring balance (Newton meter).

##### Procedure:

- Measure the mass and the weight of each stone using a spring balance.
- Tie the rope on the stone and hang it on the spring balance fixed on a ceiling and note the reading on the spring balance.
- Change the stone and repeat the first two steps and note the observation.

##### Questions:

1. What force did you observe in the experiment?
2. Where may this type of force appear?



**Fig. 3.3:** Tension force

The tension force  $T$  in Fig. 3.3, is the force which is transmitted through a string, rope, cable or wire which are massless, frictionless, unbreakable, and unstretchable when it is pulled tight by forces acting from opposite ends. The tension force is directed along the length of the wire and pulls equally on the objects on the opposite ends of the wire.

### 3.2.2 Normal Forces



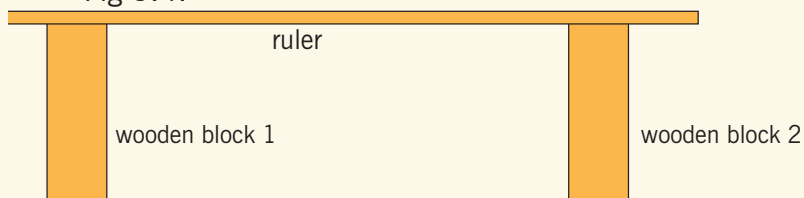
#### Activity 3.3: Investigating the normal force

**Materials:**

- Five books
- Two wooden blocks
- A meter ruler

**Procedure:**

- Arrange the blocks and the ruler as a bench as follows in Fig 3.4:



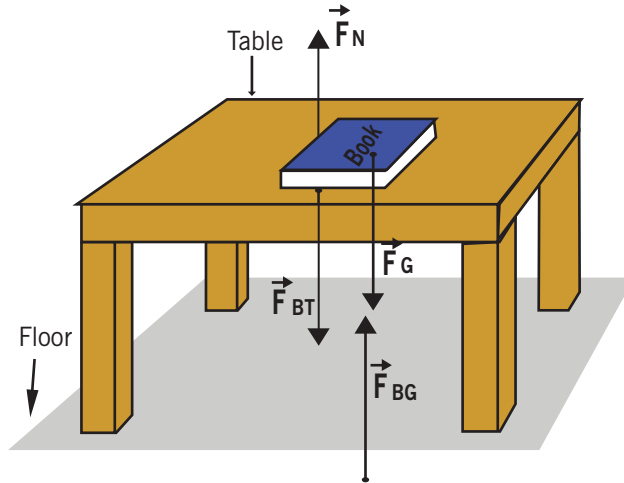
**Fig. 3.4:** Wooden blocks and the ruler laid in the form of a table.

- Lay the five books on the ruler at its middle and note your observations.
- Remove some books and note the change; then discuss the changes.

**Questions:**

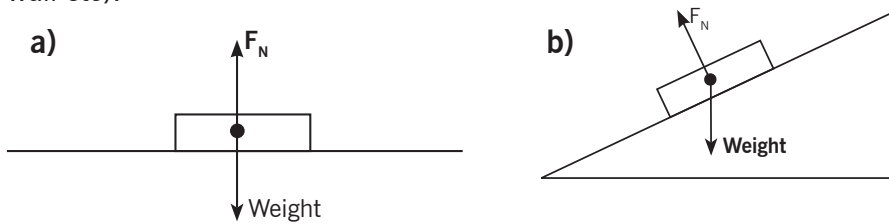
1. What are the forces involved in the experiment?
2. Which force is opposing the books not to break the ruler down?





**Fig. 3.5:** Normal forces

The normal force is a component of the contact force that is perpendicular to the surface of contact exerted on an object by the surface (of a table, wall etc).



**Fig. 3.6**

The normal force here represents the force applied by the table against the book that prevents it (the book) from sinking through the table.

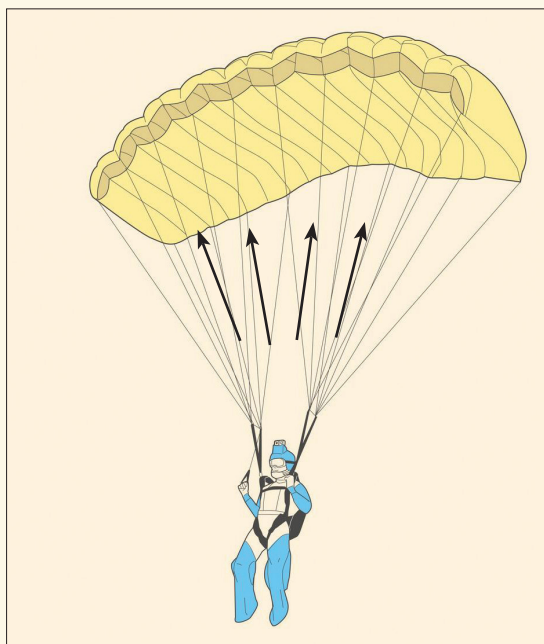
The normal force acts as resistive force that balances with the weight of the body in vertical direction as shown in fig. 3.5

### 3.2.3 Air resistance forces



#### Activity 3.4: Investigating the air resistance

Take the case of the parachute as in fig. 3.7 and answer to the following questions.



**Fig. 3.7:** Air resistance in parachutes

1. What is happening to the parachute?
2. Name the forces involved in the downward motion of the parachutist?

The air resistance is a special type of frictional force which acts upon objects as they travel through the air. The force of air resistance is often observed to oppose the motion of an object. This force will frequently be neglected due to its negligible magnitude. It is most noticeable for objects which travel at high speeds (e.g., a skydiver or a downhill skier) or for objects with large surface areas.

## 3.2.4 Spring Force

**Activity 3.5: Investigating the spring force****Materials:**

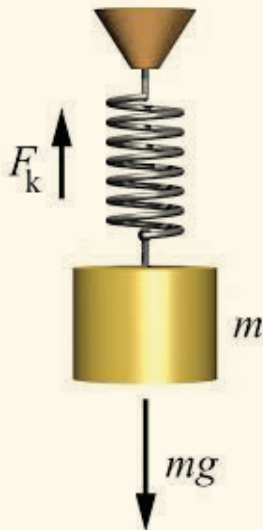
- Spring balance
- Object (Stone (s))

**Procedures:**

- Hang the spring balance in a fixed position.
- Put the stone of mass,  $m$  and notice the change on the spring balance.
- Change the stone and continue to note your observations.

**Questions:**

1. What are the forces involved in this system?
2. Which force does the spring exert on the stone?



**Fig. 3.8:** Spring forces

The spring force (**Elastic force**) is the force exerted by a compressed or stretched spring upon any object which restores its original position. An object which compresses or stretches a spring is always acted upon by a force the object to its rest or equilibrium position. The spring for  $F_k$  acts as a resistive force as shown in the figure 3.8.

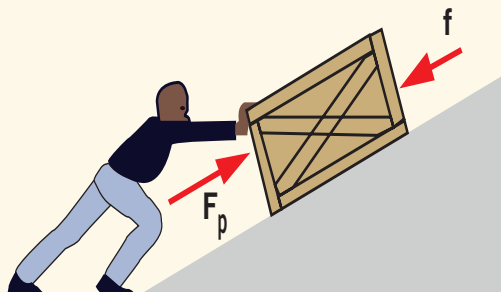
### 3.2.5 Applied forces



#### Activity 3.6 Investigating applied force

Take the case of a man pushing the box as in fig.3.9. and answer the following questions:

1. What is being done?
2. Which forces are involved in the process?
3. Name the force the man is using to push the box.



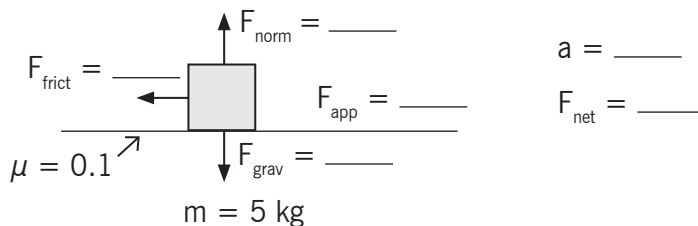
**Fig. 3.9:** Applied forces

An applied force  $F_p$  is a force in an action on the body that makes it to move or tend to move. The fig. 3.9 above shows a person pushing a body along an inclined plane. The push is the applied force acting upon the body. The force that resists (opposes) motion in the figure is denoted by  $f$ .

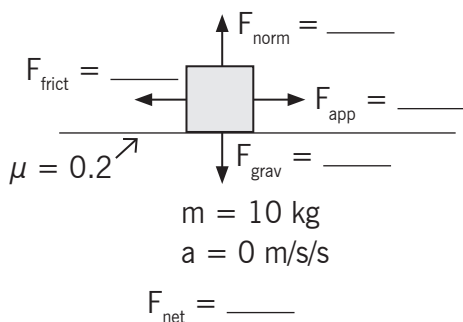
### 3.3 Unit 3 assessment

1. Fill in the blanks.
  - (a) Friction opposes the \_\_\_\_\_ between the surfaces in contact with each other.
  - (b) Friction depends on the \_\_\_\_\_ of surfaces.
  - (c) Friction produces \_\_\_\_\_.
  - (d) Sprinkling of powder on the carrom board \_\_\_\_\_ friction.
  - (e) Sliding friction is \_\_\_\_\_ than the static friction.
2. Four children were asked to arrange forces due to rolling, static and sliding frictions in a decreasing order. Their arrangements are given below. Choose the correct arrangement.
  - (a) rolling, static, sliding
  - (b) rolling, sliding, static
  - (c) static, sliding, rolling
  - (d) sliding, static, rolling

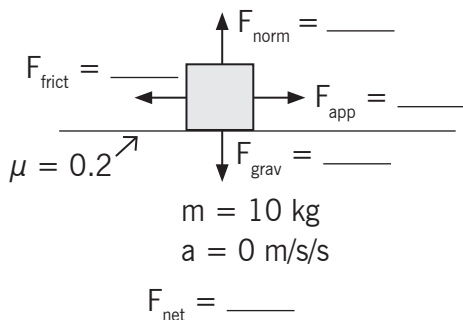
3. Alida runs her toy car on a dry marble floor, wet marble floor, a newspaper and a towel spread on the floor. The force of friction acting on the car on different surfaces in increasing order will be;
  - (a) Wet marble floor, dry marble floor, newspaper and towel.
  - (b) Newspaper, towel, dry marble floor, wet marble floor.
  - (c) Towel, newspaper, dry marble floor, wet marble floor.
  - (d) Wet marble floor, dry marble floor, towel, newspaper.
4. Suppose your writing desk is tilted a little. A book kept on it starts sliding down. Show the direction of frictional force acting on it.
5. You spill a bucket of soapy water on a marble floor accidentally. Would it make it easier or more difficult for you to walk on the floor? Why?
6. Explain why athletes use shoes with spikes.
7. Ineza has to push a lighter box and Shema has to push a similar heavier box on the same floor. Who will have to apply a larger force and why?
8. Explain why sliding friction is less than static friction.
9. Give examples to show that friction is both a friend and a foe.
10. Explain why objects moving in fluids must have special shapes.
11. A 5kg object is sliding to the right and encountering a friction force which slows it down. The coefficient of friction ( $\mu$ ) between the object and the surface is 0.1. Determine the force of gravity, the normal force, the force of friction. (Neglect air resistance).



12. A rightward force is applied to a 10-kg object to move it across a rough surface at constant velocity. The coefficient of friction between the object and the surface is 0.2. Use the diagram to determine the gravitational force, normal force, applied force, frictional force, and net force. (Neglect air resistance).



13. A rightward force is applied to a 5kg object to move it across a rough surface with a rightward acceleration of  $2\text{m/s}^2$ . The coefficient of friction between the object and the surface is 0.1. Use the diagram to determine the gravitational force, normal force, applied force, frictional force, and net force. (Neglect air resistance).



14. Eduardo applies a 4.25N rightward force to a 0.765kg book to accelerate it across a table top. The coefficient of friction between the book and the table top is 0.410. Determine the acceleration of the book.

# **Mechanics**

## Force







# Unit 4

## Density and Pressure in Solids and Fluids

### Key unit competence

At the end of this unit I should be able to define pressure and explain factors affecting it.

### My goals

By the end of this unit, I will be able to:

- Define and explain the pressure as a relationship of force acting on a surface area.
- Identify force and area as factors affecting pressure in solids and give the relationship between force, pressure and area.
- Explain how pressure varies with force and the area of contact.
- Describe liquid (mercury) in glass barometer.
- Describe how to measure atmospheric pressure and carry out calculations using the equation **Pressure = force/area** and  **$P = \rho gh$** .
- Explain the variation in atmospheric pressure with altitude.
- Explain the change in pressure by reducing or increasing area of contact and vice versa.
- Measure atmospheric pressure using a barometer, liquid in glass barometer.
- Explain the functioning of aneroid barometer.
- Describe and explain pressure transmission in hydraulic systems and explain functioning of a hydraulic press and hydraulic brakes.

## Key concepts

1. How experimentally can one determine the effect of force exerted on a solid?
2. How can one define pressure in a fluid?
3. How can pressure in liquids be measured?
4. What instrument should be used in measuring pressure?
5. Where can pressure in solids and liquids be applied in real life?



## Vocabulary

Pressure, atmospheric pressure, fluids, hydrostatic pressure, barometer, manometer.



## Reading strategy

As you read this unit – mark the paragraphs that contain definitions of key terms. Use all the information to write a definition of each key term in your own words. Perform calculations related to pressure in solids and fluids.

## 4.1 Pressure in solid

### 4.1.1 Force acting on a surface



### Activity 4.1: Investigation pressure of a solid

#### Materials:

- One concrete brick
- Balance
- A pile of sand
- A ruler
- A long beam of wood

#### Procedures:

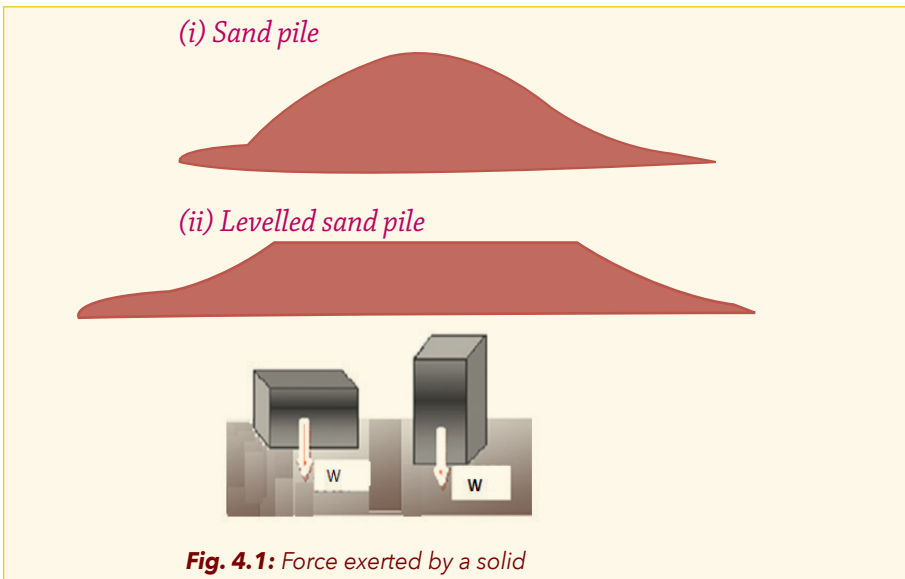
Measure the mass ( $m$ ) of the brick and calculate its weight ( $w = mg$ ).

Pour two bucketfuls of sand outside your laboratory such that it forms a pile as shown in (i).

Use the long wooden beam to spread the sand such that you have a fairly large plain surface on top of the sand pile, as shown in (ii).

- Take measurement of dimensions of one of the large surface side and calculate its area  $A_1$ .
- Take measurement of the dimensions of the small side and calculate its area  $A_2$ .
- Gently place the brick in the sand on its big side and let it rest on the sand for 15s. Carefully remove the brick from the sand. Note the depression formed on the sand and carefully measure its depth. Measure the depth at four different places and determine the average depth of the depression on the sand left by the brick. Calculate pressure exerted by the brick using  $P_1 = \frac{W}{A_1}$
- Gently place the brick on the sand on its smaller side but at a point away from the first experiment. Calculate the pressure exerted by the brick  $P_2 = \frac{W}{A_2}$

Compare and discuss the result obtained.



**Fig. 4.1:** Force exerted by a solid

If the force is concentrated on a small area, it will exert higher pressure than if the same force is distributed over a larger surface area.

**Examples:**

1. If we try and cut a fruit with the flat side of the knife it obviously won't cut. But if we take the sharp side, it will cut smoothly. The reason is, the flat side has a greater surface area (less pressure) and so it does not cut the fruit. When we take the thin side, the surface area is very small and so it cuts the fruit easily and quickly.
2. A bus or truck is heavy. It may have large tyres, so that its weight is spread over a large area. This means that the pressure on the ground is reduced; so it is less likely to sink in soft ground. This is one example of a practical application of pressure.

**4.1.2 Definition and units of pressure**

**Pressure** (symbol “ $P$ ”) is the force acting normally per unit area applied in a direction perpendicular to the surface of an object. The pressure is directly proportional to the force and inversely proportional to the area. In mathematical terms, pressure can be expressed as:  $p = \frac{F}{A}$

Pressure is a scalar quantity—that is, it has magnitude but no particular direction associated with it in space.

**4.2.1 Unit of pressure**

The unit is the pascal and is named after Blaise Pascal, the eminent French mathematician, physicist, and philosopher noted for his experiments with a barometer, an instrument to measure air pressure. The name Pascal was adopted for the SI unit Newton per square meter by the 14<sup>th</sup> CGPM in 1971.

**Example**

1. The force of 500 Newton works on a surface of 2.5 m<sup>2</sup>. Determine pressure.

**Solution :** Force ( $F$ ) = 500 Newton

$$\text{Surface area (A)} = 2.5 \text{ m}^2$$

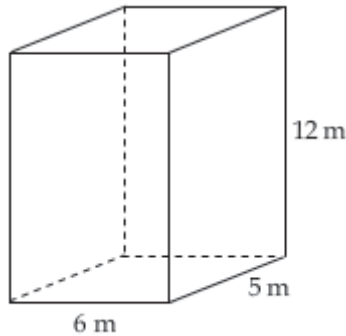
Pressure ( $P$ ) :

$$p = \frac{F}{A} = \frac{500 \text{ N}}{2.5 \text{ m}^2}$$

$$P = 200 \text{ N/m}^2$$

$$P = 200 \text{ Pa}$$

2. Mass of a box = 75 kg and acceleration due to gravity ( $g$ ) =  $10 \text{ m/s}^2$ . Determine the pressure on the floor.



**Solution:**

$$\text{Mass (m)} = 75 \text{ kg}$$

$$\text{Acceleration due to gravity } g = 10 \text{ m/s}^2$$

$$\begin{aligned} \text{Weight } w &= m g = 75 \text{ kg} \times 10 \text{ m/s}^2 \\ &= 750 \text{ kg/ms}^2 = 750 \text{ N} \end{aligned}$$

$$\text{Surface area } A = 6 \text{ m} \times 5 \text{ m} = 30 \text{ m}^2$$

$$p = \frac{F}{A} = \frac{W}{A} = \frac{750 \text{ N}}{30 \text{ m}^2} = 25 \text{ Pa}$$

### Checking my progress

1. What factors affect pressure in solids?
2. What are some examples of pressure?
3. How do solids exert pressure?
4. Find the pressure from a force of 100 N on an area of  $0.25 \text{ m}^2$
5. Find the pressure produced by a kilogram of lead on a horizontal surface if the area it rests on is  $0.02 \text{ m}^2$ ?

## 4.2 Pressure in liquids and gas



### Activity 4.2 Investigating pressure in liquids

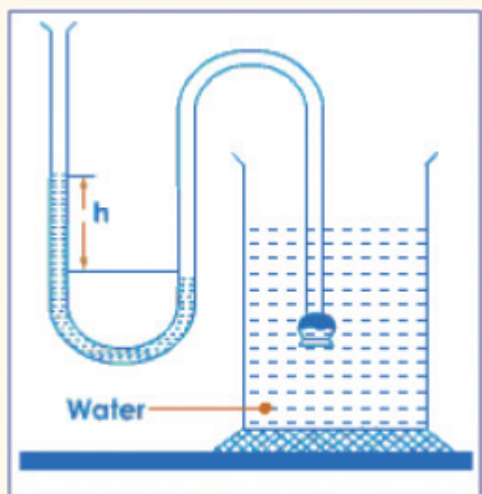
#### Materials:

- Manometer
- Water
- Beaker
- A ruler (Optional)

#### Procedures:

Try to refer to the Fig. below and do the following:

- Pour water into the beaker.
- Note the level of the manometer liquid.
- Lower the manometer nozzle in water.
- Note the change in the level of the manometer liquid.
- Lower it deeper than before and note the new changes.



**Fig. 4.2 A manometer**

#### Questions:

1. What changes are you observing?
2. Discuss the meaning and the cause of that change.
3. Prove that liquids exert pressure on a body submerged in.

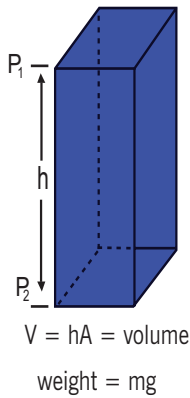
The pressure exerted by a static fluid depends only upon the **depth of the fluid, the density of the fluid,** and the **acceleration of gravity.**

The pressure in a static fluid arises from the weight of the fluid and is given by the expression:

$$P_{\text{staticfluid}} = \rho gh$$

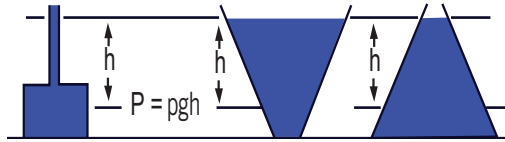
Where  $\rho$  is the density of fluid;  $g$  is acceleration of gravity; and  $h$  is depth of fluid.

The pressure from the weight of a column of liquid of area  $A$  and height  $h$  is:



Static fluid pressure does not depend on the shape, total mass, or surface area of the liquid.

$$\text{Pressure} = \frac{\text{weight}}{\text{area}} = \frac{mg}{A} = \frac{\rho Vg}{A} = \rho gh$$



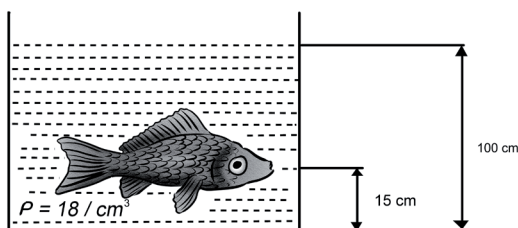
**Fig. 4.3:** Pressure in liquid

The most remarkable thing about this expression is what it does not include. The fluid pressure at a given depth does not depend upon the total mass or total volume of the liquid. The above pressure expression is easy to understand for the straight, unobstructed column, but not obvious for the cases of different geometry which are shown.

Because of the ease of visualising a column height of a known liquid, it has become common practice to state all kinds of pressures in column height units, like mmHg. Pressures are often measured by manometers in terms of a liquid column height.

### Example

Acceleration due to gravity is 10 N/kg. The surface area of fish pressed by the water above it is 6 cm<sup>2</sup>. Determine the force of water above fish that acts on fish.



**Solution:**

Acceleration due to gravity  $g = 10 \text{ N / kg}$

Surface area of fish  $A = 6 \text{ cm}^2 = 6 \times 10^{-4} \text{ m}^2$

Density of water  $r_w = 1 \text{ gram / cm}^3 = 10^3 \text{ kg / m}^3 = 1000 \text{ kg / m}^3$

Height of water  $h_w = 100 \text{ cm} - 15 \text{ cm} = 85 \text{ cm} = 85 \times 10^{-2} \text{ m}$

Unknown : Force of the water above fish that acts on fish

Using equation of pressure:

$$P = \frac{F}{A}$$

$$F = PA$$

$$F = \rho_w g h_w A$$

$$F = (1000)(10)(85 \times 10^{-2})(6 \times 10^{-4} \text{ m}^2)$$

$$F = (10^4)(510 \times 10^{-6})$$

$$F = 510 \times 10^{-2}$$

$$F = 5.1 \text{ N}$$

**Checking my progress**

1. What factors that pressure in liquids depends on?
2. How does pressure vary in liquids?
3. If the density of sea water is  $r_w = 1030 \text{ kgm}^{-3}$ , what is the pressure at 10m below sea level?
4. The density of mercury is  $r_{Hg} = 13600 \text{ kgm}^{-3}$ , what is the gauge pressure under ten metres of mercury?



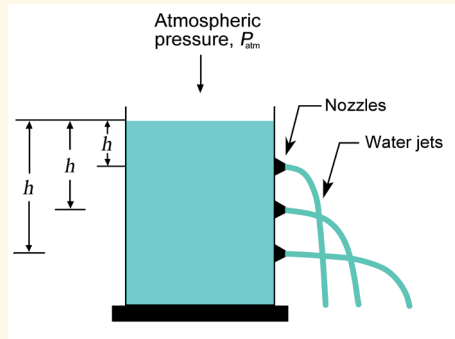
## 4.3 Atmospheric pressure

### 4.3.1 Measuring atmospheric pressure



#### Activity 4.3: Investigating about atmospheric pressure.

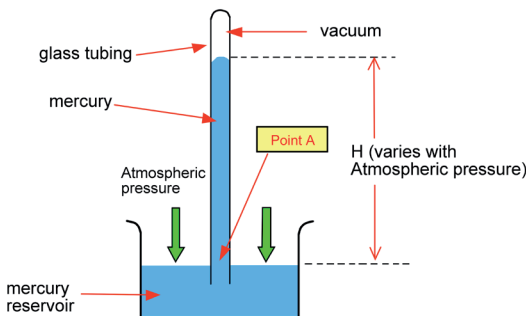
Take the case of an open container full of water. When a pin or a nail makes a hole (nozzle) near its bottom, water leaks as a jet of water (see the fig bellow).



**Fig.4.4:** Pressure in liquid

#### Questions:

1. What forces water to flow out like that?
2. Discuss and explain the properties and effects of that force..



**Fig. 4.5:** Mercury barometer

The atmospheric pressure is the weight exerted by the overhead mass of air on a unit area of surface. It can be measured with a mercury barometer,

consisting of a long glass tube full of mercury inverted over a pool of mercury:

When the tube is inverted over the pool, mercury flows out of the tube, creating a vacuum in the head space, and stabilises at an equilibrium height,  $h$  over the surface of the pool. This equilibrium requires that the pressure exerted on the mercury at two points on the horizontal surface of the pool, (inside the tube) and (outside the tube), be equal. The pressure at the point inside the tube is that of the mercury column overhead, while the pressure at that point is that of the atmosphere overhead. We obtain, from measurement of  $h$ ,

$$p = r_{Hg}gh$$

Where  $r_{Hg} = 13.6 \text{ gcm}^{-3}$  is the density of mercury and  $g = 9.8 \text{ ms}^{-2}$  is the acceleration of gravity. The mean value of  $h$  measured at sea level is 76.0 cm of mercury (Hg), and the corresponding atmospheric pressure is

$$\begin{aligned} p = r_{Hg}gh &= 13600 \text{ kgm}^{-3} \times 9.8 \text{ m/s}^2 \times 0.76 \text{ m} \\ &= 101292.8 \text{ kgm}^{-1}\text{s}^{-2} \text{ in SI units} \\ &\approx 101300 \text{ Pa} = 1.013 \times 10^5 \text{ Pa} \end{aligned}$$

. The most commonly used pressure unit is the atmosphere (atm):

$$1 \text{ atm} = 1.013 \times 10^5 \text{ Pa}$$

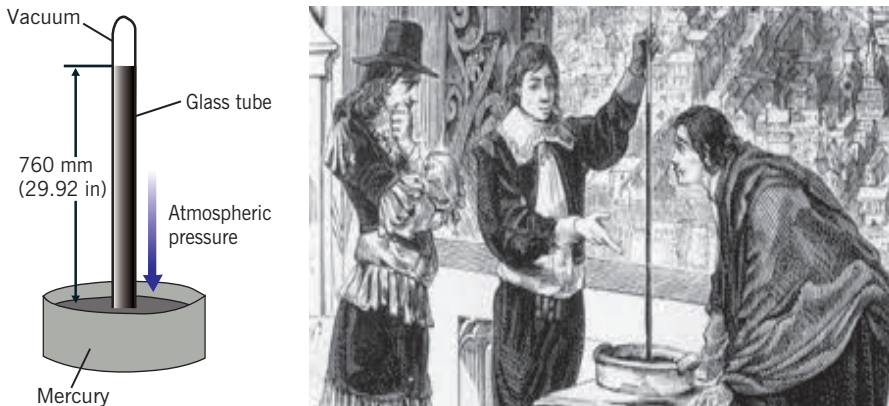
Other units of atmospheric pressure:

- **bar (b):**  $1 \text{ b} = 100000 \text{ Pa} = 10^5 \text{ Pa}$
- **millibar (mb):**  $1 \text{ mb} = 100 \text{ Pa}$
- **torriceli (torr) :**  $1 \text{ torr} = 1 \text{ mm Hg} = 134 \text{ Pa}$
- **hectopascal (hpa):**  $1 \text{ hPa} = 1 \text{ mb} = 100 \text{ Pa}$

The mean atmospheric pressure at sea level is given equivalently to:

$$\begin{aligned} P &= 1 \text{ atm} = 1.013 \times 10^5 \text{ Pa} = 1013 \text{ hPa} \\ &= 1013 \text{ mb} = 760 \text{ torr.} \end{aligned}$$

### 4.3.2 Torricelli's experiment



**Fig. 4.6:** Torricelli experiment of a simple mercury barometer

**Torricelli's experiment** was a curious project made in 1643 by the Italian physicist and mathematician Evangelista Torricelli (1608-1647) in a laboratory that attained to measure the atmospheric pressure for the first time.

#### Process:

Torricelli filled a 1 metre long tube with mercury, (closed at one end) and inverted it on a tray full of mercury. Immediately the column of mercury went down several centimetres, remaining static at some 76cm (760mm) of height. As it was observed that the pressure was directly proportional to the height of the mercury column (Hg), the millimetre of mercury was adopted as a measurement of pressure. That way, the pressure corresponded to a column of 760mm.

#### Conclusion:

The column of mercury did not fall due to the fact that the atmospheric pressure exerted on the surface of the mercury was able to balance the pressure exerted by his weight.

$$1 \text{ atm} = 760 \text{ mmHg} = 76 \text{ cmHg} = 0.76 \text{ mHg}$$

$$= 1.013 \text{ b} = 1013 \text{ hPa}$$

$$1 \text{ mb} = 1 \text{ hPa} = 0.750 \text{ mmHg}$$

### 4.3.3 Gas pressure



#### Activity 4.4: Investigating gas pressure

Imagine the case of pumping air in the ball (e.g Football):

##### Materials:

- Bicycle tube
- Brick
- Plank of wood
- Bicycle pump

##### Procedures:

- Take an empty bicycle tube.
- Lay a plank of wood across it.
- Place the brick at the centre of the plank.
- Take the pump and start to pump the gas into the bicycle tube.
- Note the changes in the position of the brick as one continues to pump.

##### Questions:

1. Explain why pumping air into the bicycle tube results in rise of the brick placed on the wooden plank.
2. Explain what would happen, if one continues to pump in more and more gas.

Pressure is determined by the flow of mass from a high pressure region to a low pressure region. Air exerts a pressure which we are so accustomed to that we ignore it. The pressure of water on a swimmer is more noticeable. You may be aware of pressure measurements in relation to your bicycle tyres.

Atmospheric pressure varies with **height** just as water pressure varies with **depth**. As a swimmer dives deeper, the water pressure on his/her increases. **As a mountain climber ascends to higher altitudes, the atmospheric pressure on him/her decreases.** His body is compressed by a smaller amount of air above it. The atmospheric pressure at 6100m is only one-half of that at level because about half of the entire atmosphere is below this elevation.

## Checking my progress

1. What do you understand by atmospheric pressure?
2. What are the factors affecting atmospheric pressure?
3. Change these quantities as indicated:
  - a.  $2.4 \text{ atm} = \dots? \dots \text{ Pa}$
  - b.  $196 \text{ kPa} = \dots? \dots \text{ atm}$
  - c.  $7.5 \text{ b} = \dots? \text{ atm} = \dots? \text{ Pa}$
4. Discuss and explain how air exerts pressure.

## 4.4 Simple pressure related applications

### 4.4.1 Drinking straw



### Activity 4.5: Investigation of atmospheric pressure in using drinking straws

#### Materials:

- Drinking straws
- Very clean bottles of mineral water
- Safe drinking water
- 50mm beakers

#### Procedures:

- Make a hole on the cover of the mineral water bottle that exactly fits the straw tube.
- Insert the straw tube through the hole such that its bottom is about 5mm from the bottom of the plastic water bottle.
- Fill the water bottle with clean and safe water and close.
- Make sure that the contacts between the tube and cover are airtight.
- Fill your beaker with safe drinking water and suck it using a straw.
- Take water/juice in the bottle (closed such that no air can get inside), but with an opening of the straw only and suck.

**Questions:**

1. What have you noticed when drinking from the glass?
2. What have you noticed when drinking from the bottle?
3. Discuss and explain the causes of your observations.



**Fig. 4.7:** Drinking straw

A drinking straw is used to create suction with your mouth. This causes a decrease in air pressure inside the straw. Since the atmospheric pressure is greater on the outside of the straw, liquid is forced into and up the straw.

**4.4.2 Siphon**



**Activity 4.6: Investigation of the siphon**

**Materials:**

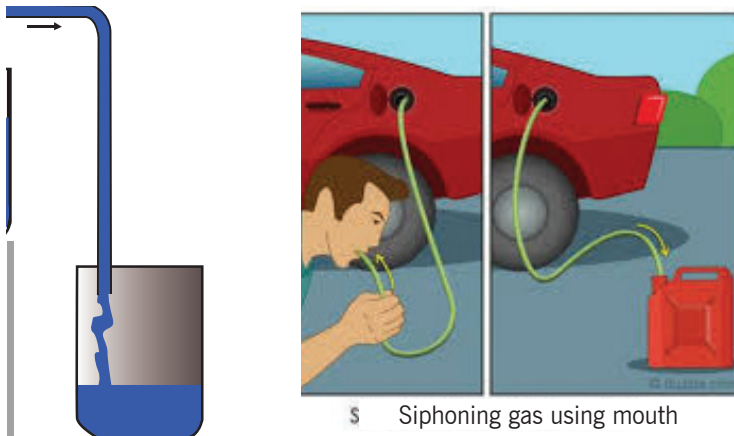
- A jerrycan
- A long flexible plastic pipe
- Bucket
- Table
- Water

**Procedures:**

- Fill a jerrycan of water on the table.
- Place the bucket down on the lower level of the table.
- Lower one end of the plastic pipe in the jerrycan.
- Let the other end of the plastic pipe be at a lower level than of the water in the jerrycan.
- Suck water from the jerrycan, and release after the water has come to your mouth.
- Let water flow from the jerrycan to the bucket freely.

**Questions:**

1. What causes the water to flow from the jerrycan to the bucket?
2. Why does the water continue to flow without sucking again?
3. Discuss and explain where this can be applied.



5 Siphoning gas using mouth

**Fig. 4.8:** *The Siphon*

With a siphon water can be made to flow “uphill”. A siphon can be started by filling the tube with water (perhaps by suction). Once started, atmospheric pressure upon the surface of the upper container forces water up the short tube to replace water flowing out of the long tube.

## 4.5 Common observations of pressure



### **Activity 4.7: Investigation of application of pressure in real life**

Study the following questions. Discuss them and give other more examples in each case.

1. Why do heavy lorries have many tyres?
2. Why do tractors (excavators, loaders, etc) have wide tyres?
3. Discuss and explain why ducks, geese have webbed feet?
4. Why do the feet of camels and elephants have wide pads?

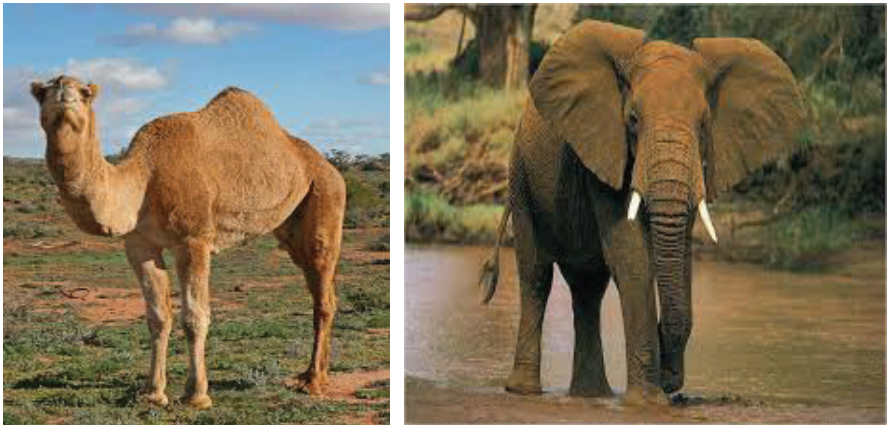
### 4.5.1 Ducks, geese, and swans all have webbed feet. The primary use for webbed feet is paddling through water



**Fig. 4.9:** Duck webbed feet

Webbed feet are useful on land as well as on water because they allow birds to walk more easily on mud. Most swimming or paddling birds have their legs and feet located at the rear of their body. This adaptation is an advantage on the water as it helps to propel the birds along.

### 4.5.2 Camel or elephant wide pads



**Fig. 4.10:** Wide pads of a Camel and an Elephant

Camels are adapted to walk long distances in deserts, hence, they have evolved to form large, broad, flat feet. More surface area means less pressure exerted on that surface, and vice-versa as the pressure is distributed on a large area, because it



would give less pressure on the sand which prevents it from sinking. **This is the same case for elephant when moving either in sandy or muddy area.**

Camels are adapted to walk long distances in deserts, hence, they have evolved to form large, broad, flat feet. More surface area means less pressure exerted on that surface, and vice-versa as the pressure is distributed on a large area, because it would give less pressure on the sand which prevents it from sinking.

### 4.5.3 Lorries with many tyres

Why do trucks that carry heavy loads have so many wheels often eighteen?  
**To distribute the load over a greater area.**



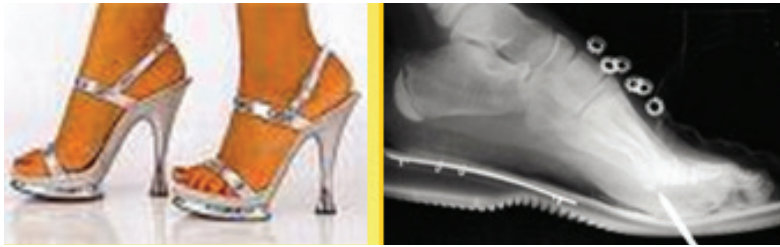
**Fig. 4.11:** Lorries with many tyres

Pavement strength is all about pressure (or stress more correctly). This is a force divided by area. If you increase the area (number of tyres) that the load is distributed over, there will be less pressure (stress) on the pavement. Think about an extreme example: Say a really heavy dump truck has only four tyres, then there are only four places for the load to go to. Further still, think about a dump truck with only one tyre! all the weight of the truck will be put onto that one tyre!

## 4.6 Unit 4 assessment

1. Which of the following equations is not correct?
  - a) Force = mass x acceleration
  - b) Density =  $\frac{\text{Volume}}{\text{Mass}}$
  - c) Pressure = density x acceleration x height
  - d) Pressure =  $\frac{\text{Force}}{\text{Area}}$
2. The static fluid pressure at any given depth depends on:
  - a) the total mass
  - b) the surface area
  - c) the distance below the surface
  - d) all of the above
3. In the equation for Pressure  $p = \rho gh$ , the units for  $g$  (SI system) are:
  - a)  $\text{kg/m}^3$
  - b)  $\text{m/s}$
  - c)  $\text{kg}\cdot\text{m/s}$
  - d)  $\text{m/s}^2$
4. What is the pressure at the bottom of a swimming pool that is 3 meters in depth?
  - a)  $1.09 \times 10^5 \text{ Pa}$
  - b)  $3.0 \times 10^4 \text{ Pa}$
  - c)  $7 \times 10^4 \text{ Pa}$
5. A substance has mass of 3kg submitted by acceleration of  $9\text{m/s}^2$ .
  - a) Find the force in Newton.
  - b) What is the pressure of it on a square of 4m for a side?
6. (a) Define pressure and state its SI unit.

- (b) Find the pressure in Pa of force,  $F = 45\text{N}$  and applied on a triangle of base of  $5\text{m}$  and height of  $3\text{m}$ .
7. Calculate the Pressure on the surface when a force of  $30\text{N}$  acts on area of  $0.2\text{m}^2$ .
8. a) Define pressure and state the S.I unit in which pressure can be expressed.  
b) A brick of mass  $3\text{kg}$  measures  $6\text{cm}$  by  $4\text{cm}$  by  $3\text{cm}$ .
- (i) What is the greatest pressure it can exert when placed on a flat surface.  
(ii) What is the least pressure it can exert?
9. Which of the shoes shown below causes most damage?why?




**Fig 4.12**

10. Copy and fill in the blanks the missing words:  
Pressure tells us how concentrated a ----- is. It is measured in ----- or -----, and is calculated using the equation:  $p = \frac{F}{A}$ . A force of  $12\text{N}$  acting over an area of  $2\text{m}^2$  causes a pressure of ----- . If the area were less, the pressure would be ----- . The dimensions of velocity are ----- . The dimensions of pressure are ----- .
11. A book of mass  $500\text{g}$  is lying on a table. Its cover measures  $25\text{cm}$  by  $29\text{cm}$ . What pressure does it exert on the table?

# **Mechanics**

## Pressure



# Unit 5

## Measuring Liquid Pressure with a Manometer

### Key unit competence

At the end of this unit, I should be able to explain the working principle of a manometer used to measure the pressure in liquids.

### My goals

By the end of this unit, I will be able to:

- Describe and explain the principle of a manometer.
- Explain hydrostatic pressure, atmospheric pressure and their measurement.
- Explain equilibrium of a liquid at rest in a vessel and communicating container.
- Explain why a liquid surface is an isobar and describe its application.
- Analyze the equilibrium of non-miscible liquids in a container and in communicating container.
- Solve problems on a manometer.
- Recognize the application of the same level of liquid in communicating vessels.
- Appreciate the results of measurement of liquid pressure using a manometer.
- Identify the use of pressure in everyday activities (aviation, automobile, sports).

## Key concepts

1. What is needed to describe pressure in liquids?
2. Which factors affect the variation of pressure in liquids?
3. Discuss the pressure effect in non-miscible liquids?
4. Discuss different applications of pressure in liquids?



## Vocabulary

U-tube, miscible and non miscible liquids, hydrostatic pressure, isobar, fluids in equilibrium.



## Reading strategy

As you read each section of this unit, put emphasis on paragraphs that contain definitions of key terms. Use this information to write the meaning of each key term in your own words.

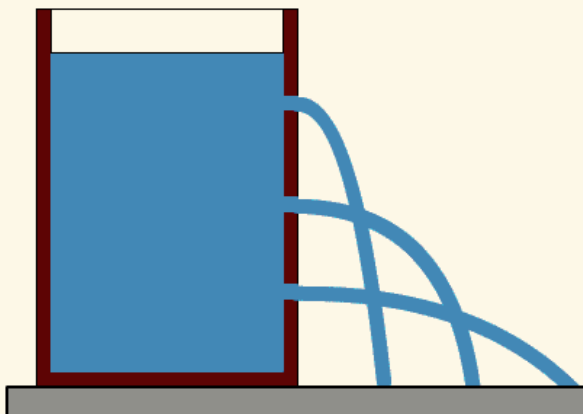
## 5.1 Pressure in liquids in equilibrium



### Activity 5.1: Investigating pressure in liquids

#### Materials:

- Large tin can or plastic bottle.
- Hammer and nail
- Water
- Ruler



**Fig. 5.1:** Water squirts further at greater depths

**Procedure:**

1. Punch 5 holes in the sides of the container, one below the other at 4cm intervals.
2. Fill the container with water.
3. Measure the distance from the bottom of the container to the point that the water squirts on the ground from each hole.
4. Plot a graph of depth (distance of the hole from the top of the water level) versus the distance water squirts on the ground.

**Questions:**

1. What is pushing water to squirt out from the container?
2. Why is water falling at different distances?
3. Discuss and explain the situation.

**5.1.1 Hydrostatic Pressure in a Liquid****Description of pressure in liquids**

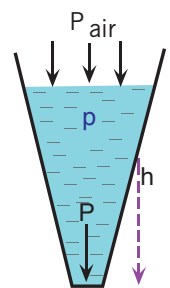
- The pressure due to the liquid alone at a given depth in a liquid at rest depends only upon the density of the liquid  $\rho$  and the distance below the surface of the liquid  $h$ . It is independent of the cross-sectional area. This is called **gauge pressure ( $p_g$ ) or Hydrostatic pressure.**

$$p_g = \rho gh$$

Pressure is not really a vector even though it looks like it in the sketches. The arrows indicate the direction of the force that the Pressure would exert on a surface it is in contact with

This is called absolute pressure (pa).

$$p_a = atm + \rho gh$$

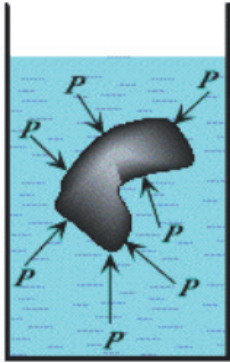


$$P = \rho gh + P_{air}$$

**Fig. 5.2:** Pressure in Liquid

### Properties of Hydrostatic pressure

- Pressure in liquids exert in all direction. The pressure on a submerged object is always perpendicular to the surface at each point on the surface.(See Fig.5.3)

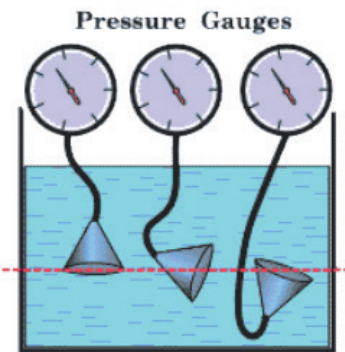


**Fig.5.3:** Pressure exerted by a liquid

- The pressure in a liquid increases linearly with depth from its value  $P_0$  at the surface that is open to the atmosphere or from some other reference point.
- If the pressure is measured above atmospheric pressure then the pressure is called the gauge pressure (hydrostatic pressure  $p_g$ )

$$p_g = r gh$$

- The pressure at a depth of a liquid plus the atmospheric pressure is called absolute pressure ( $p_a$ ):  $p_a = atm + r gh$
- In a liquid, pressure is the same at the same horizontal line.



**Fig.5.4:** Pressure is the same at the same horizontal



### 5.1.3 Pressure in relation to diving and aviation

Pressure increases with depth. It is dangerous to stay longer at a depth of 45m, since as result of high pressure, an excess of nitrogen dissolves in the blood and on return to the surface nitrogen bubbles form in the blood in the same way that bubbles form in a bottle of soda water when the cap is removed. Such a condition causes severe pain or even death. And in cases of emergency the diver is immediately placed in a decompression chamber. This is a steel tank full of compressed air and, by slowly reducing the pressure over a long period, the nitrogen becomes gradually eliminated from the blood without forming bubbles.

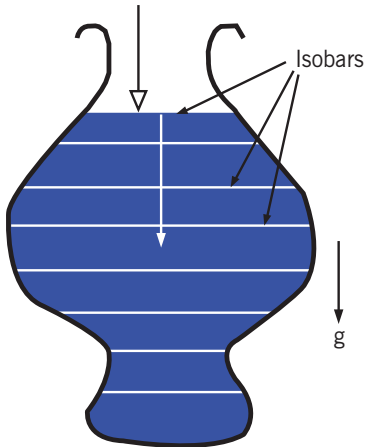
In contrast with the problem encountered by a diver, the crew and passengers in aircraft flying at high altitude would experience difficulty in breathing and consequent danger owing to low pressure. The problem is overcome by pressurising the aircraft. All openings are sealed, and a normal atmospheric pressure is maintained inside by the use of air pump.

#### Checking my progress

1. What are the factors that affect pressure in liquid?
2. What happens to liquid pressure as you go deeper in a lake?
3. How much pressure can a human withstand underwater?
4. Calculate pressure exerted on a submarine 300 m deep under the sea. Take relative density of sea to be 1.03.
5. How deep a body is under water if the pressure exerted on it is 196 kPa.
6. If the density of sea water is  $\rho = 1,030 \text{ kgm}^{-3}$ , what is the pressure at 10m below sea level?

## 5.2 Equilibrium of a liquid at rest

### 5.2.1 Equilibrium of a liquid at rest in a container and pressure difference



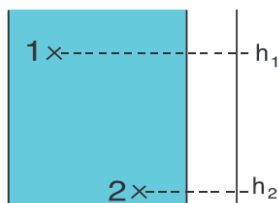
When water or any other liquid is poured into the communicating tubes, it stands at the same level in each tube which means that water finds its own level.

“Iso” means “same” and “bar” means “pressure”, so **an isobar is a surface of constant pressure**. In hydrostatics, isobars are horizontal surfaces, since pressure does not change horizontally through the same fluid.

**Fig. 5.5:** Isobar and free surface of a liquid at equilibrium

Recall that a free surface exposed to atmospheric pressure always has a pressure equal to the local atmospheric pressure. Thus, **a free surface is always an isobar**.

Pressure difference  $\Delta p$  is the pressure residing between two levels (Isobars) of different pressure, or at different depths as shown in Fig.5.6



**Fig.5.6:** Pressure difference between two points

$$\begin{aligned}\Delta p &= p_2 - p_1 \\ &= r gh_2 - r gh_1 \\ &= r g(h_2 - h_1)\end{aligned}$$

#### Example:

Calculate the pressure difference between two isobaric lines in a static liquid of density  $1.02 \text{ g/cm}^3$  at depth of 30 m and 42 m.

**Solution:**

$$r = 1.02 \text{ g/cm}^3 = 1020 \text{ kg/m}^3$$

$$h_1 = 30 \text{ m}$$

$$h_2 = 42 \text{ m}$$

$$\text{using } g = 10 \text{ m/s}^2$$

we get

$$\begin{aligned} \Delta p &= r g (h_2 - h_1) \\ &= 1020 \times 10 \times (42 - 30) \text{ Pa} \\ &= 122400 \text{ Pa} \end{aligned}$$

### 5.2.2 Equilibrium of a liquid in a communicating container



#### Activity 5.2: Investigating pressure in liquids using a communicating vessel

**Materials:**

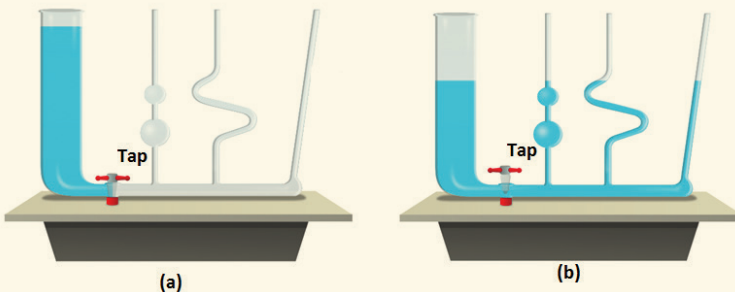
- Communicating vessel
- Coloured water

**Procedure:**

- Pour water in the big branch of the communicating vessel.
- Open the tap and observe what happens.

**Questions:**

1. Suggest what will happen after the tap is open.
2. Why are the levels of water in all branches like that, after opening the tap?



**Fig.5.7:** communicating vessel

**Communicating vessels**, sometimes referred to as **communicating vases**, is a name given to a set of containers of different shapes and sizes that are attached to a common tube at different places along the tube. This tube is sealed at one end and is attached to a larger vessel at the other end. See figure 5.8. When a liquid is poured into a communicating vessel, the liquid balances out to the same level in all of the containers regardless of the shape and volume of the containers. If additional liquid is added to one vessel, the liquid will again find a new equal level in all the connected vessels. This process is part of Stevin's Law and occurs because gravity and pressure are constant in each vessel (hydrostatic pressure).



The fluid levels are the same in each tube irrespective of their shape and size.

**Pascal's vases** is used for demonstrating that pressure in a liquid is a function of depth only. The pressure at any point in a liquid at rest depends only on the depth and on the density of the liquid but not the shape of the vessel.

**Fig. 5.8:** *Communicating vessels or Pascal's vessel*

The apparatus consists of a group of glass flasks of assorted shape linked at their base by a communal reservoir. With the pressure being dependent on the depth of the liquid only, an equilibrium situation must have the surface level in each vase equal. When the liquid is at rest in the vessel the pressure must be the same at all points along the same horizontal level, otherwise the liquid would move until the pressures were equalised.

The pressure at the bottom of the fluid at rest depends upon the depth and on the density of the fluid. It is independent on the shape of the container or the amount of liquid in the vessel.

## 5.2.3 Equilibrium of several non-miscible liquids



### Activity 5.3 Investigating pressures in non-miscible liquids

#### Materials:

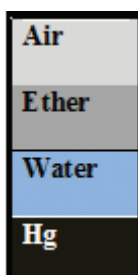
- A tall glass jar or a tall transparent plastic container
- Water
- Cooking oil
- Glycerin
- Engine oil

#### Procedure:

- Without any preferential order, pour each of the liquids, one by one and carefully into the same glass or plastic jar. Determine the density of each of the liquids that you are going to use in the exercise.
- Shake the vessel or stir the liquids you have poured in and allow them to settle for a period of 20 minutes.
- After twenty(20) minutes carefully observe and note the different layers of liquid in the jar and record the order from top to bottom.

#### Questions:

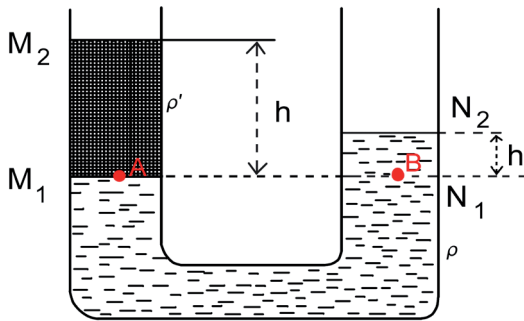
1. List the order of liquids from the top to the bottom.
2. Discuss and explain why the situation is as you have observed.



In a container, immiscible fluids are superposed according to their decreasing relative densities from the lightest to the heaviest.

**Fig. 5.9:** Non-miscible liquids in a container

### 5.2.4 The manometer density measurement



**Fig. 5.10:** Two non-miscible liquids in a communicating vessel.

As we know from the principle of Hydrostatic pressure, that the pressure is the same at the same horizontal line, we have that pressure at A is equivalent to pressure at B:

$$p_A = p_B$$

$$Atm + \rho' gh = Atm + \rho gh'$$

$$\rho' gh = \rho gh'$$

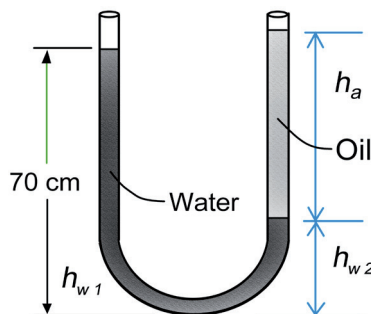
$$\rho' h = \rho h'$$

$$\frac{h}{h'} = \frac{\rho}{\rho'} \quad \text{relative density (RD)}$$

Where RD denote the Relative density.

**Example:**

Consider a U-tube whose arms are open to the atmosphere. Now water is poured into the U-tube from one arm, and light oil ( $\rho = 790 \text{ kg/m}^3$ ) from the other. One arm contains 70-cm-high water, while the other arm contains both fluids with an oil-to-water height ratio of 6. Determine the height of each fluid in that arm.



**Fig. 5.11:** U-tube

**Solution:**

The density of oil is given to be  $r_{oil} = 790 \text{ kg/m}^3$ . We take the density of water to be  $r_w = 1000 \text{ kg/m}^3$ .

The height of water column in the left arm of the manometer is given to be  $h_{w1} = 0.70 \text{ m}$ . We let the height of water and oil in the right arm to be  $h_{w2}$  and  $h_a$ , respectively. Then,  $h_a = 6h_{w2}$ . Noting that both arms are open to the atmosphere, the pressure at the bottom of the U-tube can be expressed as:

$$\begin{aligned}
 p_{atm} + r_w g h_{w1} &= p_{atm} + r_a g h_a + r_w g h_{w2} \\
 r_w g h_{w1} &= r_a g h_a + r_w g h_{w2} \\
 r_w h_{w1} &= r_a 6h_{w2} + r_w h_{w2} \\
 h_{w2} &= \frac{r_w h_{w1}}{6r_a + r_w} = \\
 h_{w2} &= \frac{70r_w}{6r_a + r_w} \\
 &= \frac{70 \times 1000}{6 \times 790 + 1000} = 12.2 \text{ cm}
 \end{aligned}$$

Hence, we can find that:

$$h_a = 6h_{w2} = 6 \times 12.2 \text{ cm} = 73.2 \text{ cm}$$

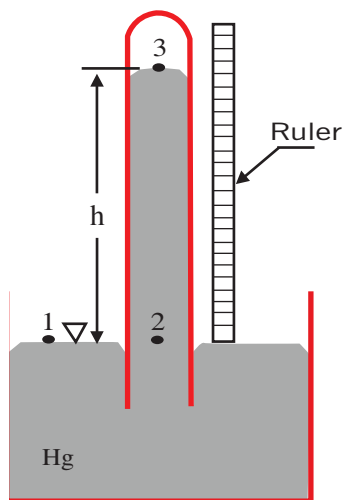
## 5.3 Applications of hydrostatics

### 5.3.1 Pressure measurement with hydrostatics

A standard mercury barometer has a mercury column of about 76 cm in height, in a glass or plastic jar or tube closed at one end, with an open mercury-filled reservoir at the base (Fig. 5.12). The first barometer of this type was devised in 1643 by Evangelista Torricelli.

Torricelli had set out to create an instrument to measure the weight of air, or air pressure, and to study the nature of vacuums.

If the indicator scale is calibrated to give altitude instead of air pressure, the device is called an “altimeter”.



**Fig. 5.12:** Mercury Barometer

This gadget is formed by inverting a glass tube filled with mercury into a mercury bath. At the top of the mercury column in the tube (point 3 in the sketch), the pressure is nearly a total vacuum. The pressure at point 1 is atmospheric, and this pressure holds the mercury column at some height  $h$ , as measured by a ruler.

The hydrostatics equation can be used to solve for atmospheric pressure in terms of the known values of  $h$ ,  $g$ , and the density of mercury:

$$\begin{aligned}
 \text{Atm} &= p_1 = p_2 = p_3 + \rho_{\text{Hg}}gh \\
 &= p_3 + \rho_{\text{Hg}}gh \\
 &= 0 + 13600 \text{ kg/m}^3 \times 9.8 \text{ m/s}^2 \times 0.76 \text{ m} \\
 &= 101292.8 \text{ Pa} \\
 &\approx 1.013 \times 10^5 \text{ Pa}
 \end{aligned}$$

Atmospheric pressure can support a column of water 10.3m high, or a column of mercury of length 76cm.

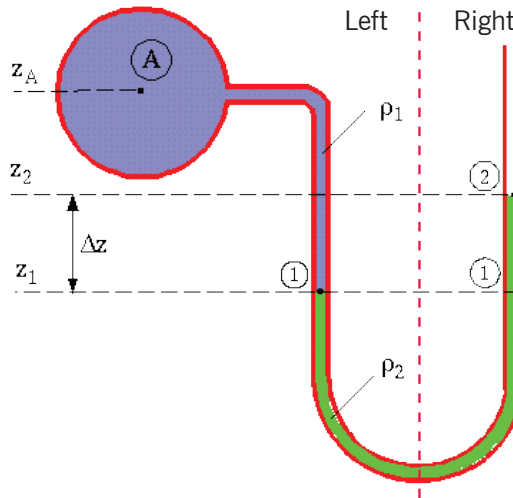
### 5.3.2 U-tube Manometer

#### The U-tube Manometer case

This device consists of a glass tube bent into the shape of a “U”, and is used to measure some unknown pressure.

For example, consider the sketch below (Fig. 5.13), where a U-tube manometer is used to measure pressure  $P_A$  in some kind of tank or machine.





**Fig. 5.13:** The U-Tube manometer

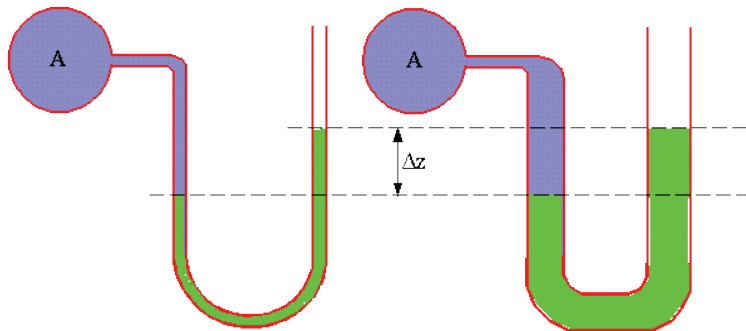
Consider the right side and the left side of the manometer separately. The equation for hydrostatics gives:

$$P_A = P_1 = \rho_2 g(z_2 - z_1) + P_2$$

Since both points labeled 1 in the figure are at the same elevation in the same fluid, they are at equivalent pressures. Also, point 2 is exposed to atmospheric pressure, thus  $P_2 = P_{atm}$ . The two equations above can be equated and solved for  $P_A = P_{atm} + \rho_2 g(z_2 - z_1)$ .

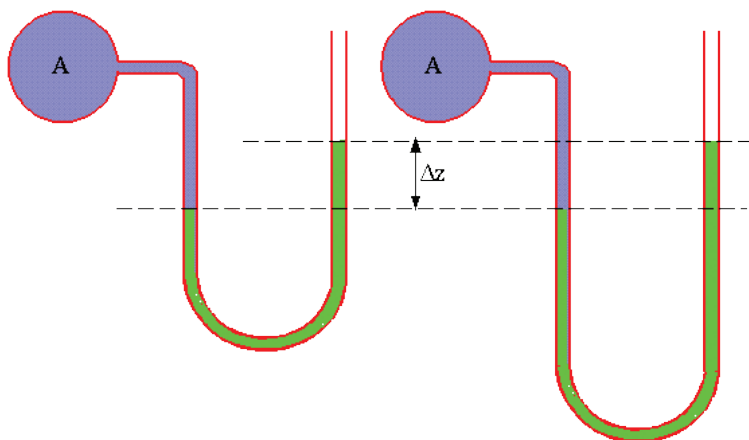
#### Some “rules” to remember about the U-tube manometer

- Manometer height difference does not depend on tube diameter** (except, of course, if the diameter is very small, and surface tension effects are significant).



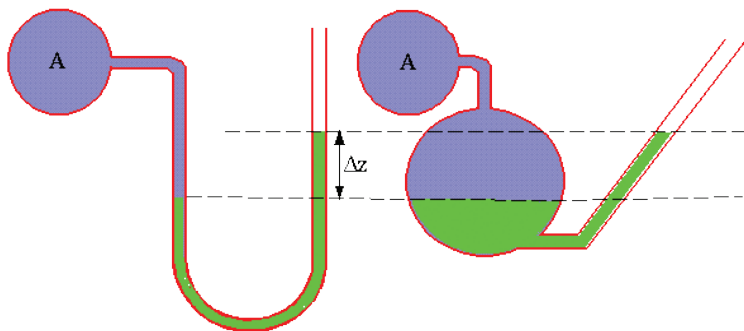
**Fig. 5.14:** The Manometer and its diameter

- b) **Manometer height difference does not depend on tube length** (provided, of course, that the length is enough to handle the height difference).



**Fig. 5.15:** *The Manometer and its tube length*

- c) **Manometer height difference does not depend on tube shape** (except, of course, if the tube is of very small diameter, and surface tension effects are significant).

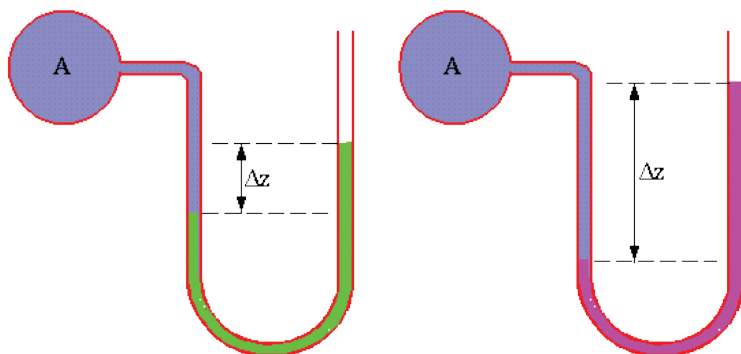


**Fig. 5.16:** *The Manometer and its shape*

Recall that the shape of a container does not matter in hydrostatics. This implies that a U-tube manometer does not have to be in a perfect U shape.

Although the column height difference between the two sides does not change, an inclined manometer has better resolution than does a standard vertical manometer because of the inclined right side. Specifically, for a given ruler resolution, one “tick” mark on the ruler corresponds to a finer gradation of pressure for the inclined case.

- d) **Manometer height difference does depend on the fluid used in the manometer.**

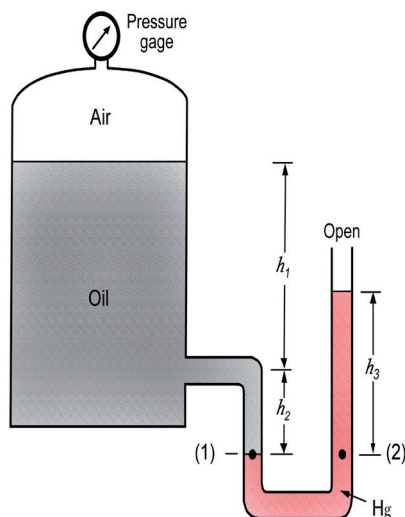


**Fig. 5.17:** *The Manometer and manometer fluid*

For the same pressure difference, a dense manometer liquid will have a smaller difference in column height than a less dense manometer liquid. This too can be used advantageously. If a small pressure difference is being measured, it is better to use a light fluid, since the resolution and accuracy are improved.

**Example:**

A closed tank contains compressed air and oil (R.D oil = 0.90) as is shown in Figure below. A U-tube manometer using mercury (R.D.Hg = 13.6) is connected to the tank as shown. The column heights are  $h_1 = 92$  cm,  $h_2 = 15$  cm, and  $h_3 = 23$  cm. Determine the pressure reading (Pa) of the gage.



**Solution:**

Pressure at level (1) is equal to pressure at level (2)

Hence

$$p_1 = p_2$$

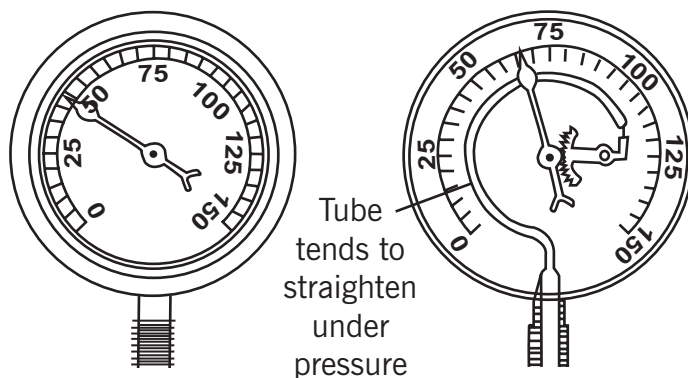
$$p_{air} + p_{oil} = p_{atm} + p_{Hg}$$

Hence,  $p_{air} = p_{atm} + p_{Hg} - p_{oil}$

$$\begin{aligned} p_{air} &= p_{atm} + r_{Hg}gh_3 - r_{oil}g(h_1 + h_2) \\ &= 1.013 \times 10^5 + 13600 \times 10 \times 0.23 - 900 \times 10 \times (0.92 + 0.15) \\ &= 122950 \text{ Pa} \end{aligned}$$

### 5.3.3 Pressure measurement with bourdon gauges

An **aneroid barometer** (Bourdon gauges) uses a small, flexible metal box called an aneroid cell. This aneroid capsule (cell) is made from an alloy of beryllium and copper. The box is tightly sealed after some of the air is removed, so that small changes in external air pressure cause the cell to expand or contract. This expansion and contraction drives mechanical levers and other devices which are displayed on the face of the aneroid barometer.



**Fig. 5.18:** Bourdon Gauges

A mercury barometer is long and inconvenient, heavy; and contains a liquid that is hazardous and easily split; therefore, an aneroid barometer is commonly used. Aneroid means without liquid. It is compact and portable; it has no liquid to spill and no problem with vapour or air getting in.

## 5.3.4 Sphygmomanometer

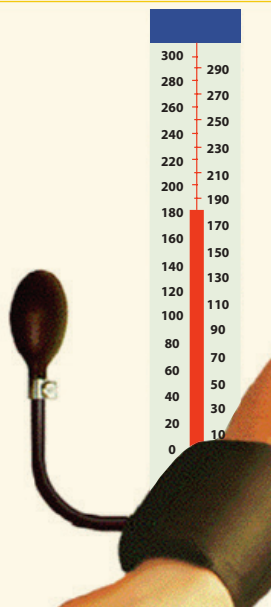


### Activity 5.3: Measuring blood pressure

#### Materials:

A Sphygmomanometer (blood pressure cuff)

1. Deflate the air bladder of the cuff and place it around the upper arm so it fits snugly. If you're right handed, you should hold the bulb/pump in your left hand to inflate the cuff. Hold it in the palm so your fingers can easily reach the valve at the top to open and close the outlet to the air bladder.
2. Put the head of the stethoscope just under the edge of the cuff, a little above the crease of the person's elbow.
3. Inflate the cuff with brisk squeezes of the bulb. Watch the pressure gauge as you do it, you should go to around 150 mmHg or until the pulse is no longer heard. At this point blood flow in the underlying blood vessel is cut off by pressure in the cuff.



4. At around 150, slightly open the valve on the air pump (held in your left hand). This part takes practice, it's important that you don't let the air out too suddenly.
5. Now, pay attention to what you hear through the stethoscope as the needle on the pressure gauge falls. You will be listening for a slight "blrrp" or something that sounds like a "prrrpshh". The first time you hear this sound; note the reading on the gauge. This value is the systolic blood pressure.
6. The sounds should continue and become louder in intensity. Note the reading when you hear the sound for the last time. This is the diastolic blood pressure.

**Fig. 5.19:** The Sphygmomanometer

#### Questions:

In your own words, describe how to use a blood pressure cuff (sphygmomanometer).

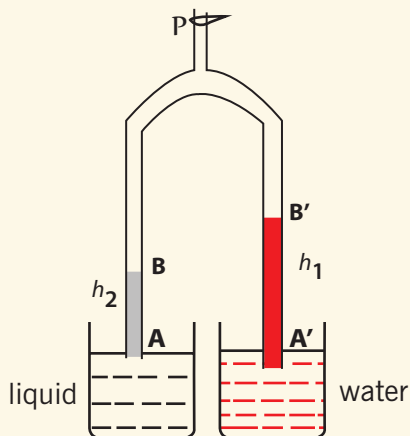
Blood pressure is measured in millimeters of mercury (mm Hg). A typical blood pressure is 120/80mm Hg, or "120 over 80." The first number represents the pressure when the heart contracts and is called the systolic blood pressure. The second number represents the pressure when the heart relaxes and is called the diastolic blood pressure.

### 5.4 Hare's apparatus



#### Activity 5.4: Calculating relative density of a liquid

Observe at the fig. 5.20 below and try to answer the following questions:



#### Questions:

1. Calculate pressure at B and B' due to  $h_1$  and  $h_2$  respectively.
2. If Pressure at A and A' are equal, find the relative density of the liquids. ( take density of water to be  $1000\text{kg/m}^3$ )

Fig. 5.20. Hare's apparatus

#### Finding the Relative Density of Two Liquids Using Hare's Apparatus

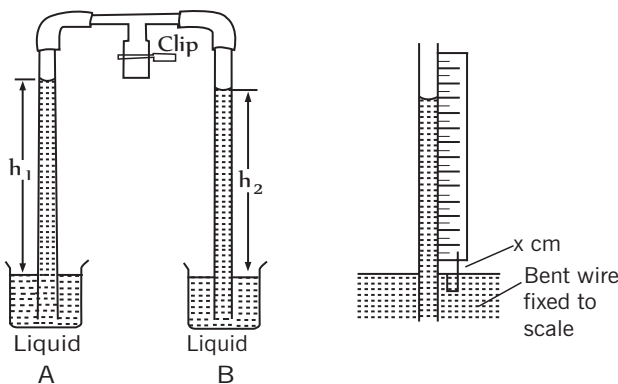


Fig. 5.21: Hare's apparatus

A vacuum pump is connected to the T-clip and some air is sucked out. The clip is then closed. The pressure inside the glass tubes falls and the liquids rise up the tubes. The liquids rise until the pressure due to each liquid column is equal to the difference between atmospheric pressure and the pressure  $P$  inside the glass tube. To measure the heights of the liquids  $h_1$  and  $h_2$  accurately, bend a paperclip into an asymmetric U shape and attach it to the bottom of the ruler. Measure the readings on the ruler respectively.

The pressure at the base of liquid A is then  $P_A = P + \rho_A gh_1$

The pressure at the base of liquid B is then  $P_B = P + \rho_B gh_2$

Equating these gives  $P + \rho_A gh_1 = P + \rho_B gh_2$

Hence

$$\rho_A gh_1 = \rho_B gh_2 \text{ dividing every side by } g$$

$$\rho_A h_1 = \rho_B h_2 \text{ by proportion we get}$$

$$\frac{\rho_A}{\rho_B} = \frac{h_2}{h_1}$$

### Example

In the Hare's apparatus, water rises to a height of 26.5 cm in one limb. If a liquid rises to a height of 20.4 cm in the other limb, what is the relative density of the liquid?

### Solution:

The height of water  $h_w = 26.5 \text{ cm}$

The height of the liquid  $h_l = 20.4 \text{ cm}$

Considering the  $\rho_w$  and  $\rho_l$  as the density of the water and the liquid respectively, we get the relation that:

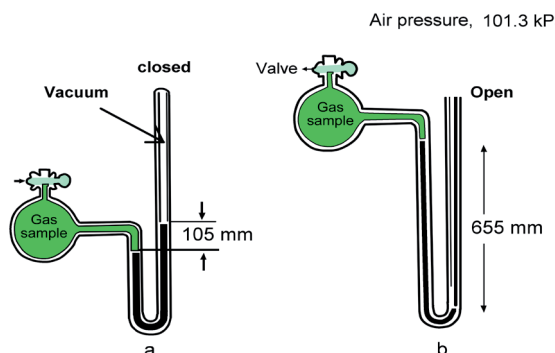
$$\rho_l gh_l = \rho_w gh_w \text{ simplifying } g \text{ from both sides}$$

$$\rho_l h_l = \rho_w h_w, \text{ hence,}$$

$$R.D = \frac{\rho_l}{\rho_w} = \frac{h_w}{h_l} = \frac{26.5}{20.4} = 1.299 \approx 1.3$$

## 5.5 Unit 5 assessment

1. Find the pressure of that gas sample in Fig 5.22

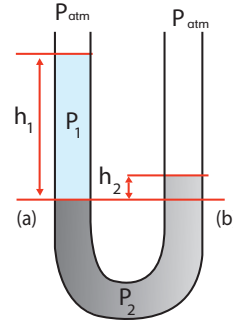


**Fig. 5.22:** The Opened and closed tube manometer measures pressure

2. Mercury has a density that is about 14 times greater than that of water. If you were to build a barometer that uses water instead of mercury, how would the height of the column of water needed compare to that of the mercury?
  - a) higher than
  - b) lower than
  - c) equal to
  - d) can't tell
  
3. A nurse administers medication in a saline solution to a patient by infusion into a vein in the patient's arm. The density of the solution is  $1.0 \times 10^3 \text{ kg/m}^3$  and the gauge pressure inside the vein is  $2.5 \times 10^3 \text{ Pa}$ . How high above the insertion point must the container be hung so that there is sufficient pressure to force the fluid into the patient?
  
4. A tube in a form of U with uniform section contains mercury. In one of the branches, they pour successively 8 cm of water and 6 cm of ether. Determine the difference in height between the two free levels; the volume weight of ether is  $7115 \text{ N/m}^3$ , that of mercury is  $1333 \times 10^2 \text{ N/m}^3$ . (Volume weight  $w = r g$  and its unit is  $\text{N/m}^3$ )

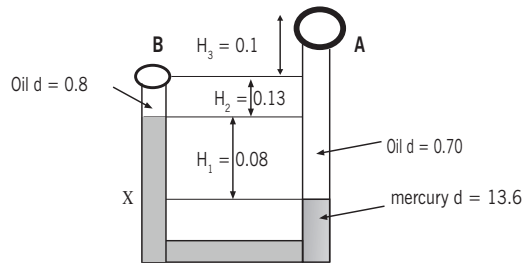


5. In a tube in a form of U, Fig 5.23, they pour mercury. Then in one branch they pour 20 cm of water and 20 cm of naphtha in the other branch. Calculate the difference in height from the surfaces of separation. Volume weight of naphtha is  $6157\text{N/m}^3$ .



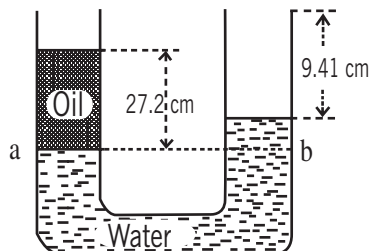
**Fig. 5.23:** U-tube manometer 1

6. Determine the pressure difference between points A and B, for the set-up shown in Fig 5.24. Volume weight unit of water is taken as  $\omega = \rho g = 9790\text{N/m}^3$ .



**Fig. 5.24:** U-Tube manometer 2

7. In a tube in a form of U, they pour mercury and then water in the other branch. The height of water column is 10cm. What could be the height of oil column that could bring the two levels of mercury into the same horizontal plan? The oil volume weight is  $7752\text{ kg/m}^3$
8. Calculate the pressure at a depth of 2 m in swimming pool filled with water.
9. Water and oil are poured into the U-shaped tube, fig 5.25, open at both ends, and do not mix. They come to equilibrium as shown in the fig. below. What is the density of the oil?



**Fig. 5.25:** The U-tube manometer 3

---

# **Mechanics**

## Forces

---



# Unit 6

## Application of Pascal's principle

### Key unit competence

By the end of this unit I should be able to explain transmission of pressure in fluids at rest and describe its applications.

### My goals

By the end of this unit, I will be able to:

- Explain static pressure of fluids at rest and describe transmission of pressure in static fluids.
- Explain Pascal's principle.
- Describe applications of Pascal's principle (Hydraulic press, Hydraulic brake, Water Towers, Hydraulic jack).
- Illustrate Pascal's principle and explain the functioning of hydraulic jack, lift and dump truck, and car brakes.
- Learn that pressure exerted on an enclosed fluid is equally transmitted in all directions.
- Understand how pressure transmitted in a fluid produces a large force when a small force is applied to it.

### Key concepts

1. What do you understand on Pascal's Principle?
2. Which factors affect the application of Pascal's principle?
3. Discuss transmission of pressure in a hydraulic press.
4. Discuss different applications of Pascal's principle in real life.



## Vocabulary

Hydraulic press, water tower, cylinder, piston,, liquids in equilibrium, cross section area.



## Reading strategy

When you are reading this section, take time to understand what you are reading especially the meaning of key words. This will help you to express them in your own words. You will be able to express your calculations and draw your own experiments about Pascal principle.

### 6.1 Static pressure in fluids at rest



#### Activity 6.1: Investigating the variation of pressure with depth

##### Materials:

- Bath
- Water

##### Procedures:

- Pour water in the bath.
- Let it be in equilibrium for like 5 minutes.

##### Questions:

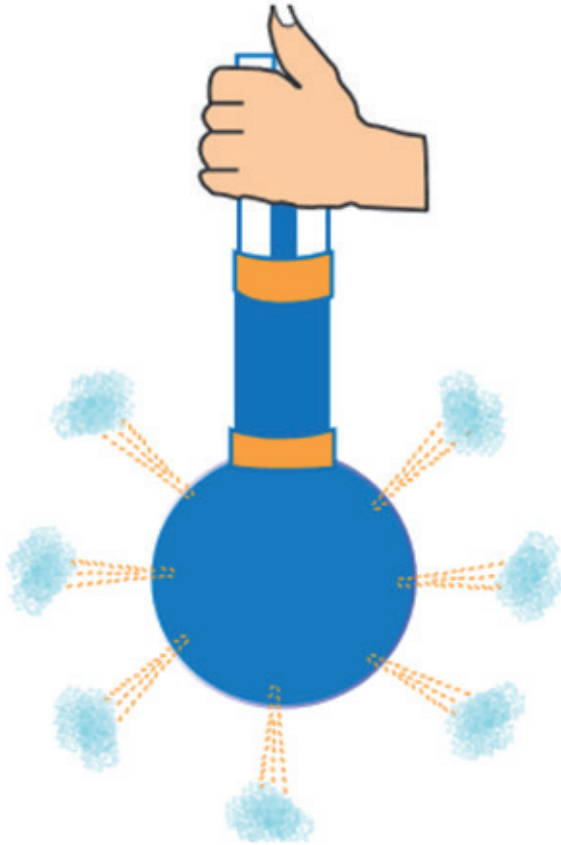
1. Is that water flowing?
2. What is the state of motion that water has?
3. How would you find the pressure at the bottom of the bath?

**Static fluid** (also called **hydrostatics**) is the science of fluids at rest, and is a sub-field within fluid mechanics. It embraces the study of the conditions under which fluids are at rest in stable equilibrium. The use of fluid to do work is called hydraulics, and the science of fluids in motion is fluid dynamics.

A **fluid** is defined as a substance that continually deforms (flows) under an applied shear stress (deformation). All gases and liquids are fluids. Fluids are a subset of the phases of matter and include **liquids**, **gases** and **plasmas**.

When pressure is applied at a point in a confined fluid, it is transmitted equally in all directions.

This can be demonstrated using a glass vessel as shown in Fig.6.1. When force is applied to the piston the pressure exerted on the water is transmitted equally throughout the water so that water comes out of all the holes with equal force.



**Fig.6.1:** Transmission of pressure in liquid

***“Any external pressure applied to a fluid is transmitted undiminished throughout the liquid and onto the walls of the containing vessel”***

Hydraulic devices like the hydraulic press and car brakes are based on the above principle.

## 6.2 Pascal's principle and its application



### Activity 6.2: Investigating the variation of pressure with depth

#### Materials:

- A clean water bottle (eg: Inyange mineral water bottle)
- Water
- A pin

#### Procedure:

- Take water in the bottle.
- Using a pin to make holes on different sides.
- Pump air in the bottle from its opening.

#### Questions:

1. Does water fall at the same distances as before?
2. Compare the distance of water from the lower part and that of the upper part of the bottle.
3. What causes water to appear to fall at the same distances while it is being pressed?

In the physical sciences, **Pascal's law** or **Pascal's principle** (1647) states that: "pressure applied to an enclosed fluid, is transmitted equally to every part of the fluid."

*For all points at the same absolute height in a connected body of an incompressible fluid at rest, the fluid pressure is the same. The difference of pressure due to a difference in elevation within a fluid column is given by:*

$$\Delta p = \rho g \Delta h$$

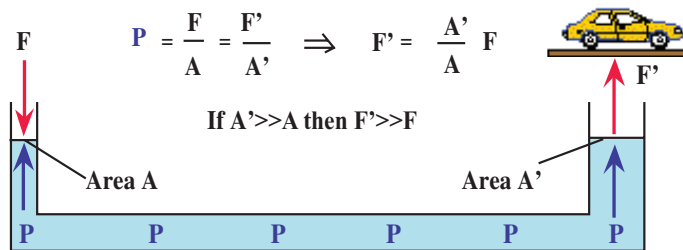
Where, using SI units,

- $\Delta P$  is the hydrostatic pressure (in pascals  $Pa$ ), or the difference in pressure at two points within a fluid column, due to the weight of the fluid;
- $\rho$  is the fluid density (in kilograms per cubic meter  $kg/m^3$ );
- $g$  is sea level acceleration due to Earth's gravity (in meters per second squared  $m/s^2$ );
- $\Delta h$  is the height of fluid above (in meters  $m$ ), or the difference in elevation between the two points within the fluid column.

The intuitive explanation of this formula is that the change in pressure between two elevations is due to the weight of the fluid between the elevations. Note that the variation with height does not depend on any additional pressures. Therefore Pascal's law can be interpreted as saying that any change in pressure applied at any given point of the fluid is transmitted undiminished throughout the fluid.

### 6.2.1 Pascal's Principle calculation

A hydraulic pump is used to lift a car; When a small force  $F$  is applied to a small area  $A$  of a movable piston it creates a pressure  $p = F/A$ . This pressure is transmitted to and acts on a larger movable piston of area  $A'$  which is then used to lift a car.



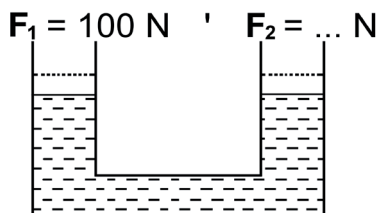
**Fig. 6.2:** The Hydraulic pump

When a force is applied at one end it is transferred to the other end. From the relation  $F = P \times A$ , We see that a small force (thrust) applied at the end with a small area will produce a larger force at the end with the larger area:  $F' = p \times A'$

Since pressure equals force per unit area, then it follows that  $\frac{F}{A} = \frac{F'}{A'}$

**Example:**

If the area of  $A_1 = 0.001 \text{ m}^2$  and the area of  $A_2 = 0.1 \text{ m}^2$ , external input force  $F_1 = 100 \text{ N}$ , then find the external output force  $F_2$  (see the figure below)



**Solution:**

$$A_1 = 0.001 \text{ m}^2$$

$$A_2 = 0.1 \text{ m}^2$$

$$F_1 = 100 \text{ N}$$

Unknown: External output force  $F_2 = ?$

$$P_1 = P_2$$

$$\frac{F_1}{A_1} = \frac{F_2}{A_2} \Leftrightarrow F_2 = \frac{F_1 \times A_2}{A_1} = \frac{100 \text{ N} \times 0.1 \text{ m}^2}{0.001 \text{ m}^2} \\ = 10000 \text{ N}$$

In both cases the volume of the fluid remains the same. So if the small piston moves through a distance  $h$  and as a result the large piston moves through a distance  $h'$ , then the two volumes replaced by the piston and the fluid must be equal i.e. volume displaced by small piston = volume occupied when large piston moves or  $V = h \times A = h' \times A'$ . This gives the velocity ratio:

$$VR = \frac{h}{h'} = \frac{A'}{A}$$

So if the area of the large piston is  $\pi R^2$  and that of the small piston is  $\pi r^2$ , then

$$VR = \frac{h}{h'} = \frac{A'}{A} = \frac{R^2}{r^2}$$

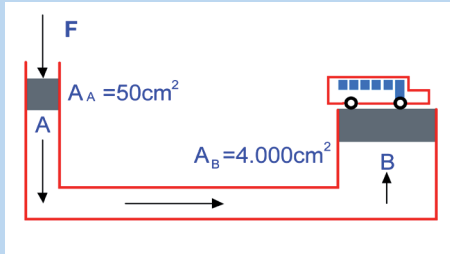
This same principle is also used to produce a great force in a car lift and car transmission systems as well as the hydraulic brake.

If the ratio of the areas is 5, a force of 100N on the small piston will produce a force of 500N on the large piston, and the small piston must be pushed 50cm to get the large piston to rise 10cm.

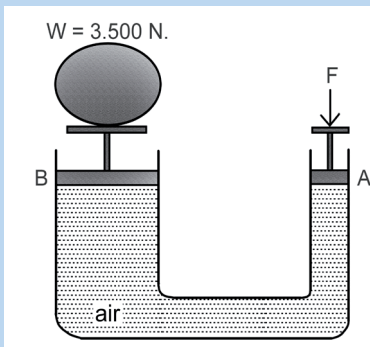


## Checking my progress

1. Car's weight = 16,000 N. What is the external input force  $F$ ?



2. Area of A is  $60 \text{ cm}^2$  and area of B is  $4,200 \text{ cm}^2$ , determine the external input force of  $F$ .

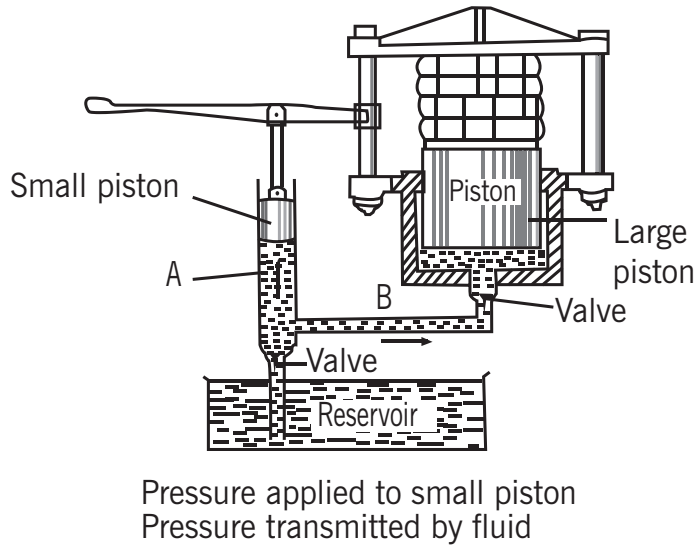


3. The hydraulic lift has a large cross section and a small cross section. Large cross-sectional area is 20 times the small cross-sectional area. If on the small cross section is given an input force of 25 N, then determine the output force.

## 6.3 Application

### 6.3.1 Hydraulic press

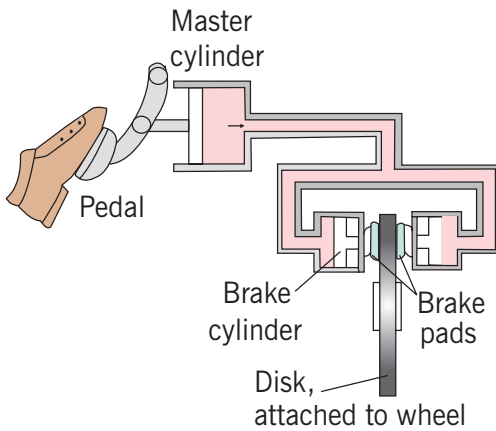
A **hydraulic press** is a hydraulic mechanism for applying a large compressive force. It is the hydraulic equivalent of a mechanical lever, and is also known as a **Bramah press** after the inventor, Joseph Bramah, of England in 1795. Hydraulic presses are the most commonly-used and efficient form of modern press. A fluid, such as oil, is displaced when either piston is pushed inward.



**Fig. 6.3:** The Hydraulic press

### 6.3.2 Hydraulic brake

The **hydraulic brake** is a braking mechanism which uses brake fluid, typically containing ethylene glycol, to transfer pressure from the controlling unit, which is usually near the driver of the vehicle, to the brake cylinder, which is usually at or near the wheel of the vehicle.



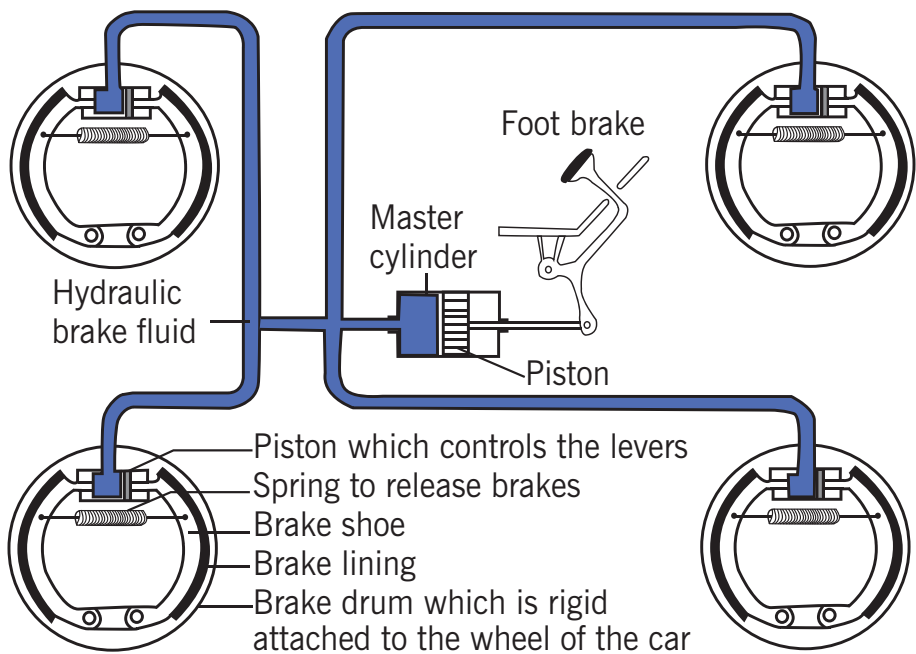
The most common arrangement of hydraulic brakes for vehicles consists of a brake pedal, a vacuum assist module, a master cylinder, hydraulic lines, and a brake rotor and/or brake drum.

**Fig. 6.4:** The Hydraulic brake

At one time, passenger vehicles commonly employed disc brakes on the front wheels and drum brakes on the rear wheels. However, four wheel disc brakes have become more popular, replacing drums on all but the most basic vehicles. As the brake pedal is pressed, leverage multiplies the force applied from the pedal to a vacuum booster. The booster multiplies the force again and acts upon a piston in the master cylinder.

As force is applied to this piston, pressure in the hydraulic system increases forcing fluid through the lines to the slave cylinders. The slave cylinders for a drum brake are a pair of opposed pistons which are forced apart by the fluid pressure, while for a disc brake a single piston is forced out of its housing.

The slave cylinder pistons then apply force to the brake linings, which are referred to as shoes in the case of drum brakes or as pads in the case of disc brakes. The forces applied to the linings cause them to be pushed against the rotating metal of the drum or rotor. The friction between the linings and the metal causes a braking torque to be generated, slowing the vehicle.



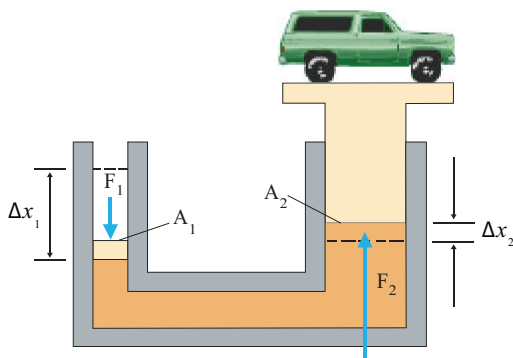
**Fig. 6.5:** The hydraulic brake

The fluid pressure from the master cylinder is transferred equally to all the brake shoes.

### 6.3.3 Water Towers

A **water tower** or **elevated water tower** is a large elevated water storage container constructed for the purpose of holding a water supply at a height sufficient to pressurise a water distribution system. Pressurisation occurs through the elevation of water; for every 10.20 cm of elevation, it produces 1 kilopascal of pressure. 30m of elevation produces roughly 300 kPa, which is enough pressure to operate and provide for most domestic water pressure and distribution system requirement.

### 6.3.4 Hydraulic lift car



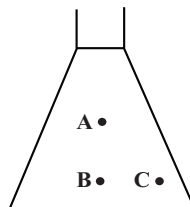
**Fig. 6.6:** The hydraulic lift.

Because the increase in pressure is the same on the two sides, a small force  $F_1$  at the left produces a much greater force  $F_2$  at the right. A vehicle undergoing repair is supported by a hydraulic lift in a garage.

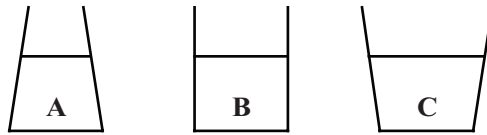
### 6.4 Unit 6 assessment

1. The maximum gauge pressure in a hydraulic lift is 18 atm. What largest mass vehicle can it lift if the diameter of the output line is 22 cm?
2. What is the total pressure on a diver 45.0 m below the sea?
3. The master cylinder of a brake system has a radius of 0.100 cm and the cylinders at the brake pads have radii of 4.00 cm. If Debi can apply a force of 150N on the brake pedal, what is the force applied to slow down her car?
4. Find the pressure needed to push water to the top of the Tower, a height of 8.0 m (use mass units), the density of water is  $1.0 \text{ g/cm}^3$ .
5. Find the total force on the filled school dam whose dimensions are 5.0m by 2.0 m. The average depth is 1.0 m.
6. Rank the pressures at the three points of the figure below:

- a)  $p_A < p_B = p_C$
- a)  $p_A < p_B < p_C$
- a)  $p_A < p_C < p_B$
- a)  $p_C < p_A < p_B$

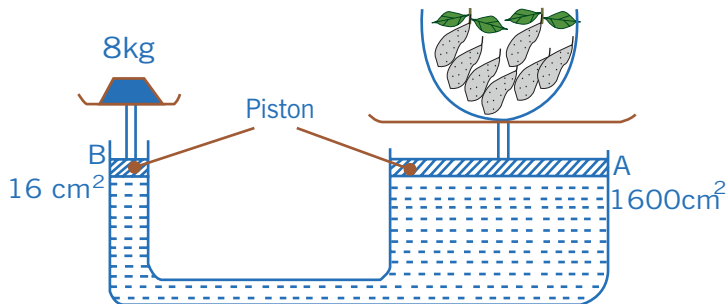


7. Three containers of different shape, but with bases of equal area (Fig 6.7) are filled with water to the same height.



**Fig. 6.7:** Containers

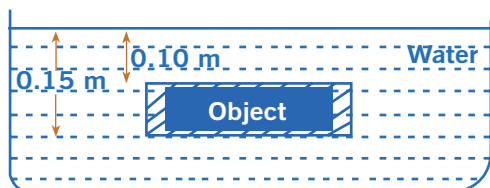
- a) The weight of the water is the greatest in container...
    - (i) A
    - (ii) B
    - (iii) C
    - (iv) The weight of the water is the same in all the three containers.
  - b) The pressure at the bottom of the container is the greatest in container...
    - (i) A
    - (ii) B
    - (iii) C
    - (iv) The pressure at the bottom is the same in all the three containers
8. Calculate the pressure due to water column of height 100 m (Take  $g = 10 \text{ m s}^{-2}$  and density of water =  $10^3 \text{ kg m}^{-3}$ ). What height of mercury column will exert the same pressure? (Density of mercury =  $13.6 \times 10^3 \text{ kg m}^{-3}$ )
  9. What is the pressure due to water pressure 100 m below the surface of a lake?
  10. Figure 6.8 shows a hydraulic weight bridge which works on the principle of Pascal's law.



**Fig. 6.8:** The Hydraulic press

- a) What is the pressure at B?
- b) What is the pressure at A?

- c) What is the weight of the vegetable on the large piston A if the weight bridge is in equilibrium?
11. A regularly shaped object is immersed in water of density  $1000 \text{ kgm}^{-3}$  (Fig 6.9)



**Fig. 6.9:** Pressure exerted on a body in water

- a) Calculate the water pressure at the top and the bottom of the object.
- b) What is the resultant pressure on the object?

# Mechanics

# Pressure

---

---





# Unit 7

## Archimedes' Principle and Atmospheric Pressure

### Key unit competence

---

By the end of this unit, I should be able to determine atmospheric pressure using a Barometer.

### My goals

---

By the end of this unit, I will be able to:

- Explain atmospheric pressure and state its units.
- Explain applications of atmospheric pressure.
- Illustrate Archimedes principle in air.
- Explain buoyant/up thrust force and Archimedes principle in liquid.
- Explain the existence of atmospheric pressure.
- State the S.I. units of atmospheric pressure, identify and name the instruments for measuring atmospheric pressure.
- Mention and explain the applications of atmospheric pressure.
- Explain the Archimedes principle in fluids: up thrust, factors affecting up thrust, state the principle and formula.
- Apply the Archimedes principle: floating and sinking.
- Explain the applications of Archimedes principle in air. (Aerostat, Baroscope)

## Key concepts

1. How to detect the existence of atmospheric pressure in our environment?
2. What is atmospheric pressure?
3. What do we use to measure atmospheric pressure?
4. Explain the key concept of buoyancy and up-thrust.
5. Discuss Archimedes' principle in fluids (liquids and gases).
6. Discuss different applications of Archimedes principle in fluids in real life.



## Vocabulary

Barometer, up-thrust force, floating, sinking, aerostat, atmospheric pressure, buoyancy.



## Reading strategy

When reading this unit, emphasise the paragraphs that contain definitions of key terms. Use all the information you have learnt to define each key term in your own words, describe and discuss Archimedes principle and its application in real life and other related calculations.

## 7.1 Atmospheric pressure

### 7.1.1 Existence of atmospheric pressure

The existence of the atmospheric pressure can be proved by the following experiments.

1. Crushing can experiment.
2. Overturned glass full of water
3. Magdeburg Hemisphere.

#### 7.1.1.1 Crushing can experiment



### Activity 7.1: Investigating the effect of atmospheric pressure on a hot closed can.

With reference to the Fig. 7.1, and the provided materials, do the following activity and answer the questions.

**Materials:**

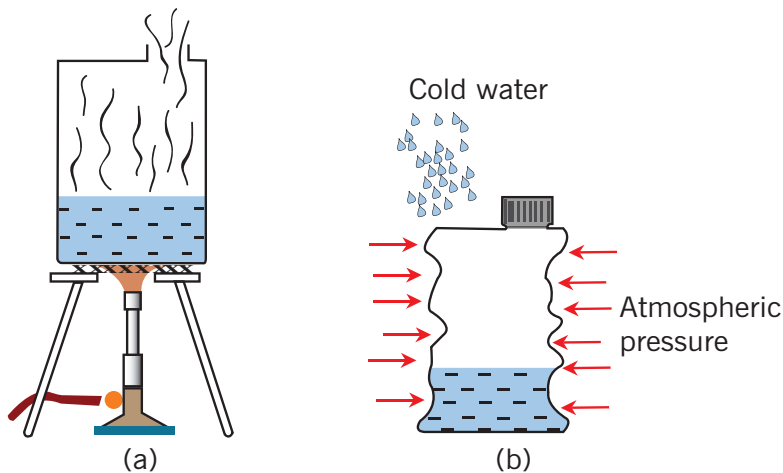
- Bunsen burner
- Tripod stand
- A metal can with a lid
- Wire gauze
- Water

**Procedure:**

- Pour water into the metal can.
- Pour the water till it fills about  $\frac{1}{3}$  of the volume of the can.
- Heat the water in the can on the lighted Bunsen burner until it boils.
- Remove the can from the burner and close its lid.
- Allow the can to cool and carefully observe.

**Questions:**

1. What do you think may have caused the changes observed?
2. Discuss and explain your observations.
3. Comment on the situation relating it with atmospheric pressure.



Water in a can is heated

The can is closed and is cooled down rapidly by pouring cold water on it, it crushes instantly, due to the high atmospheric pressure from the surrounding

**Fig. 7.1:** The collapsing or crushing can

When a can filled with hot water is closed and is cooled down it will crush instantly. This experiment proves that atmospheric pressure acts on everything on the surface of the earth.

### 7.1.1.2 Inverted glass full of water experiment



## Activity 7.2: Investigating the effect of atmospheric pressure on inverted glass full of water.

### Materials:

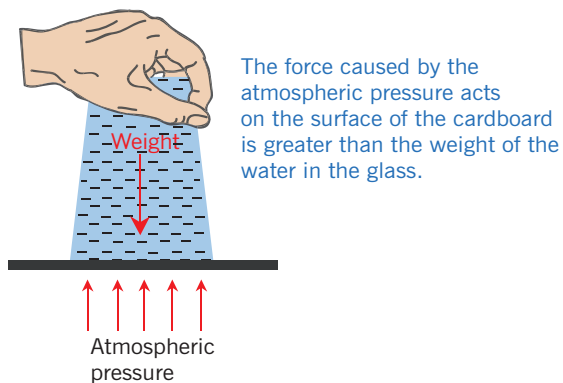
- Glass
- Water
- Stiff paper or cardboard

### Procedures:

- Pour water in the glass and make it full.
- Make sure there is no air bubble inside.
- Place the paper on the glass.
- Put your hand on the paper and the other hand holds the glass, at the bottom.
- Very quickly, turn the glass upside down with your hand still on the paper.
- Then remove the hand holding the paper as in Fig. 7.2.

### Questions:

1. What have you observed?
2. Discuss and explain why the water has not poured out from the glass.
3. Comment on the observation relating it to the atmospheric pressure.

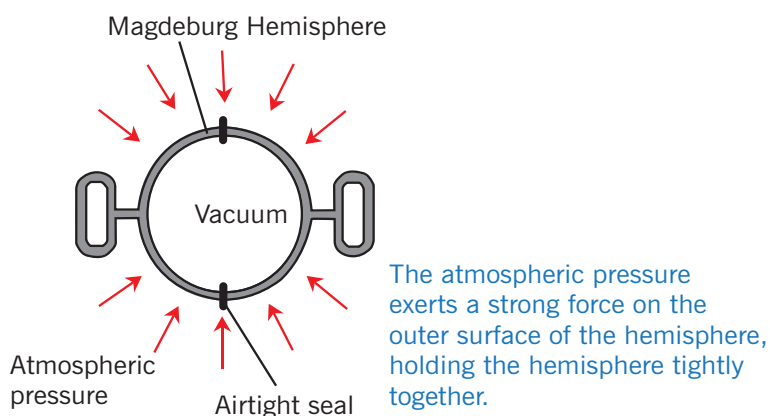


**Fig. 7.2:** Inverted glass full of water

The cardboard does not fall and the water remains in the glass even though it's not supported by anything. This is because the force due to the atmospheric pressure acting on the surface of the cardboard is greater

than the weight of the water in the glass. This experiment proves that atmospheric pressure is present on the surface of the earth.

### 7.1.1.3 Magdeburg Hemisphere



**Fig. 7.3:** Magdeburg hemisphere

When the air inside the hemisphere is pumped out so that the hemisphere becomes a vacuum, the hemisphere cannot be separated even by a very great force. This is because when the air is pumped out, the pressure inside the hemisphere becomes very low. The atmospheric pressure exerts a strong force on the outer surface of the hemisphere, holding the hemisphere tightly together.

### 7.1.2 Atmospheric pressure units

The **standard atmosphere** (symbol: **atm**) is a unit of pressure defined as 101325 Pa (1.01325 bar). It is sometimes used as a *reference* or *standard pressure*.

#### Pressure units and equivalencies

A pressure of 1 atm can also be stated as:

≡ 1.01325 bar

≡ 101325 pascal (Pa) or 101.325 kilopascal (kPa)

≡ 1013.25 millibars (mbar, also mb)

≡ 760 torr

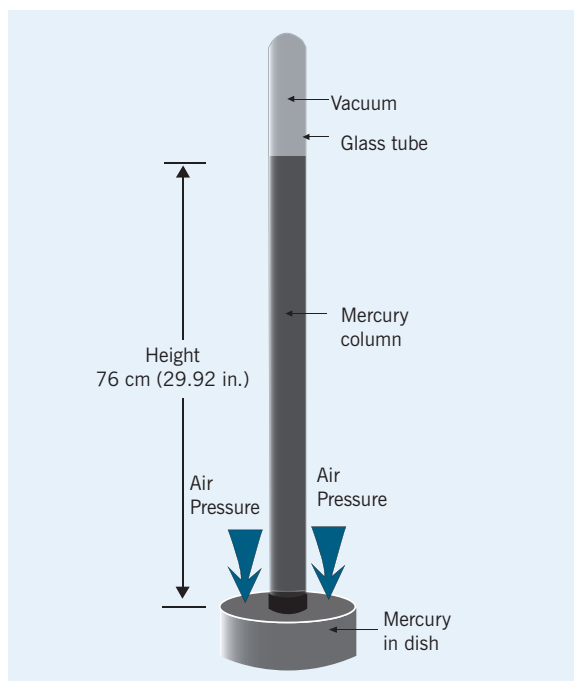
≈ 760.001 mm-Hg, 0°C, subject to revision as more precise measurements of mercury's density become available

≈ 1033.227 452 799 886 cm-H<sub>2</sub>O, 4°C

### 7.1.3 Instruments for measuring atmospheric pressure

#### 1. Mercury Barometer

A mercury barometer consists of a thick-walled glass tube, which is closed at one end.

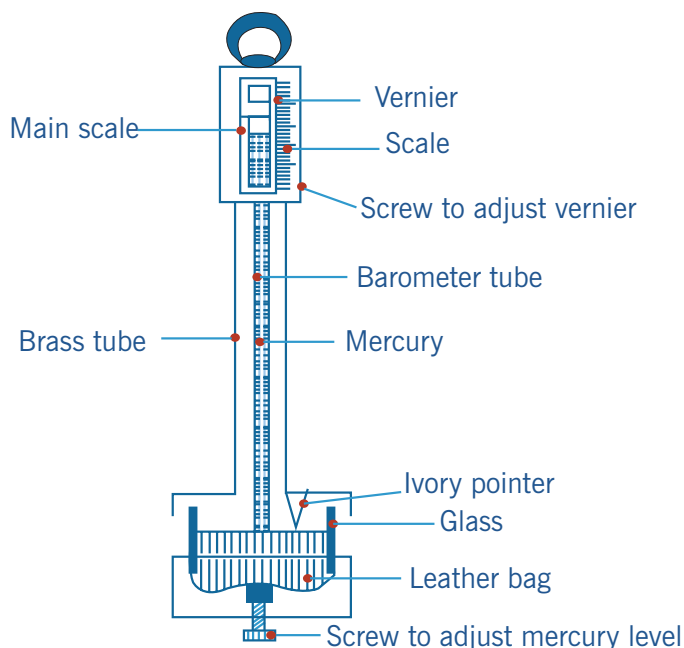


**Fig. 7.4:** The Mercury barometer

The tube is completely filled with mercury and inverted several times to remove air bubbles. The tube is then completely filled again with mercury. After all the air has been removed, the open end of the glass tube is inverted into a container of mercury. The mercury column drops until it reaches a height about 76cm above the lower surface. The space between the top of the mercury and the end of the tube contains no air; it is a complete vacuum. The column of mercury in the tube is supported by the atmospheric pressure and its height depends on the magnitude of the atmospheric pressure.

#### 2. Fortin Barometer

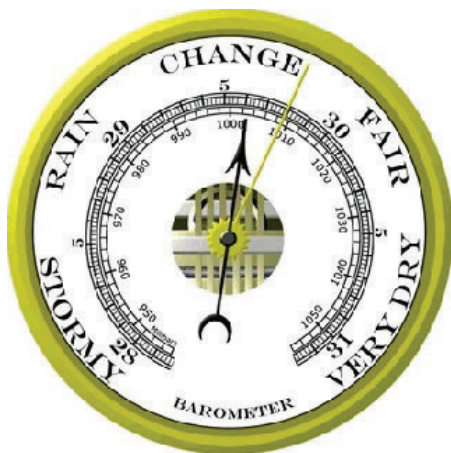
A fortin barometer is a type of mercury barometer which has a higher accuracy. This barometer has a vernier scale which gives a more accurate reading of the atmospheric pressure. The mercury level in the container can be adjusted by a screw until the pointer touches the surface of the mercury. This eliminates the zero error.



**Fig. 7.5:** The Fortin Barometer

### 3. Aneroid Barometer

An aneroid barometer does not use any liquid. It consists of a sealed metal chamber in the form of a flat cylinder with flexible walls. The chamber is partially evacuated and a spring helps prevent it from collapsing.



**Fig. 7.6:** The Aneroid barometer

The chamber expands and contracts in response to changes in atmospheric pressure. The movement of the chamber walls is transmitted by a mechanical lever system which moves a pointer over a calibrated scale.

The Aneroid Barometer can be used as an altimeter (to determine altitude) by mountaineers or pilots to determine an airplane's altitude. The scale can be calibrated to give readings of altitude equivalent to a range of values of atmospheric pressure.

An aneroid barometer is also used as a weather glass to forecast the weather. Rain clouds form in large areas of lower pressure air, so a fall in the barometer reading often means that bad weather is coming.

## 7.1.4 Application of atmospheric pressure

### 7.1.4.1 Drinking Straw



#### **Activity 7.3: Effect of atmospheric pressure when using a drinking straw**

With reference to activity 4.4 in unit 4, discuss and explain how atmospheric pressure is applied when drinking using a straw.

When drinking with a straw, one has to suck the straw. This causes the pressure in the straw to decrease. The external atmospheric pressure, which is greater, will then act on the surface of the water in the glass, causing it to rise through the straw.

### 7.1.4.2 Rubber Sucker



#### **Activity 7.4: Investigating the atmospheric pressure with a rubber sucker**

##### Materials:

- Rubber sucker
- Window glass or a telephone

##### Procedure:

- Lay the rubber sucker on the window glass and push slightly.
- Lay the rubber sucker on the screen or the back part of the telephone as shown in Fig 7.7 and try to pull it back.

##### Question:

Discuss and explain why the rubber sucker is sticking on the window glass or on the telephone's screen.





**Fig. 7.7:** The Rubber sucker used in holding phones

When the rubber sucker is put onto a smooth surface, usually a glass or tiled surface, the air in the rubber sucker is forced out. This causes the space between the surface and the sucker to have low pressure. The contact between the rubber sucker and the smooth surface is airtight. The external atmospheric pressure, which is much higher, acts on the rubber sucker, pressing it securely against the wall.

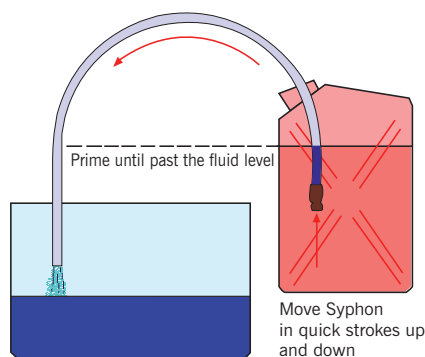
#### 7.1.4.3 Siphon



### Activity 7.5: Investigating atmospheric pressure when using siphon

With reference to activity 4.5 in Unit 4, discuss and explain the role of atmospheric pressure in pushing out the liquid from the can

A rubber tube can be used to siphon liquid from a container at a higher level to another at a lower level. For example, we can remove petrol from the petrol tank of a vehicle or dirty water from an aquarium. The tube is first filled with the liquid and one end is placed in the liquid in the container A. The other end is placed at a level which must be lower than the surface of the liquid in container A.



**Fig. 7.8:** Siphoning water from a jerrycan

The pressure in the rubber at the lower end is equal to atmospheric pressure plus the pressure due to  $h$  cm column of liquid. As the pressure at the lower end is greater than the atmospheric pressure, the liquid flows out.

### 7.1.4.4 Lift pump



## Activity 7.6: Application of pressure of liquid in using a lift pump

### Materials:

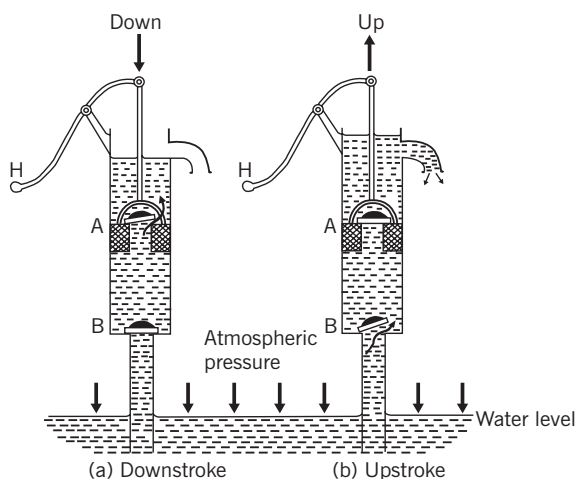
- Lab lift pump
- Bucket
- Water

### Procedure:

- Take water in the bucket.
- Try to fetch water from the bucket using the lab lift pump

### Questions:

1. Discuss and explain the principle function of the lift pump used above.
2. Where can this be applied to help the society?



**Fig. 7.9:** A Lift pump sucking water from a well

A lift pump is used to pump water out of a well or to a higher level. The greatest height to which the water can be pumped is 10 m. This is equivalent to the atmospheric pressure.

When the plunger (H) is lifted (upstroke), the upper valve closes and the lower valve opens (see Fig.7.9 b). The atmospheric pressure, acting on the surface of the water, causes water to flow past valve B into the cylinder.

When the plunger is pushed down, the lower valve closes and the upper valve opens (downstroke). Water flows above the plunger. When the plunger is next lifted, the upper valve closes again and the lower valve opens once more. The atmospheric pressure, acting on the surface of the water, forces water past the lower valve into the cylinder. Simultaneously, the water above the plunger is lifted and flows out through the spout. This process is repeated until sufficient water is obtained.

### Checking my progress

1. Explain how rubber suckers could be used to help lift panes of glass safely.
2. If one of the windows in a plane flying at high altitude breaks, what do you think will happen?
3. Water has a lower density than mercury. Is the column of liquid in a mercury barometer taller or shorter than one in a barometer using water?
4. If the density of water is  $1000 \text{ kg/m}^3$  and atmospheric pressure is  $100,000 \text{ Pa}$ ; how high will the column of water in a perfect water barometer be? (Take  $g$  for the Earth as  $10 \text{ N/kg}$ ).
5. What would happen to the mercury level in a mercury barometer if:
  - (a) The atmospheric pressure went down
  - (b) The atmospheric pressure went up
  - (c) A little air leaked into the tube above the mercury
  - (d) The barometer was taken up a high mountain
  - (e) The temperature of the room where the barometer was, got higher.

[Remember that mercury is a dangerous substance. It should not be used by learners and you should certainly not heat it].
6. Find out what is meant by:
  - (a) a millibar
  - (b) an isobar

## 7.2 ARCHIMEDES PRINCIPLE

### 7.2.1 The Principle of buoyancy and factors affecting upthrust force



#### Activity 7.7: Investigating the upthrust (buoyancy) of water

With reference to the Table 7.2, do this experiment and answer the questions.

##### Materials:

- A stone of less than 1 kg.
- Water
- Eureka can
- Sewing thread
- Dynamometer
- Measuring cylinder

##### Procedure:

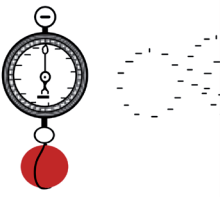
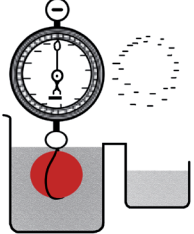
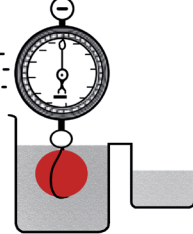
1. Pour water in the Eureka can and make it full.
2. Tie the thread on the stone
3. Measure its weight in air using the dynamometer and record it to be  $w_1$
4. Submerge the stone in water still on the dynamometer and record the new weight  $w_2$
5. Measure the weight of water overflowed in the measuring cylinder and record it as  $w_3$
6. Find the difference  $w' = w_1 - w_2$

##### Questions:

1. Compare the results obtained from step 5 and 6.
2. What is the volume of the stone?
3. Discuss and explain your findings in question 1.

An object weighs less in water than it does in the air. This loss of weight is due to the upthrust of the water acting upon it and is equal to the weight of the liquid displaced.

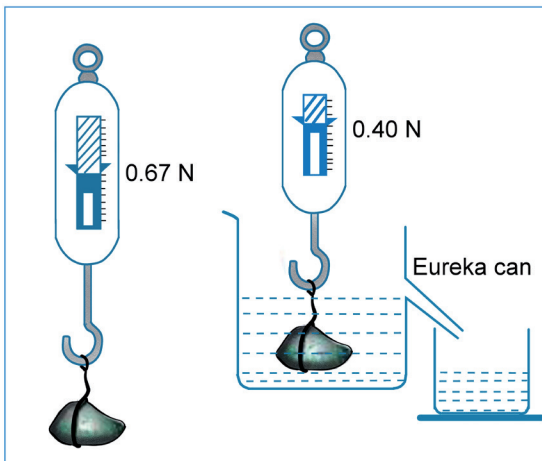
Table 7.2: Archimedes principle of buoyancy

Object weighed in air is (say) 640g.	Object weighed in water is (say) 410g.	Object weighed in salt water is (say) 400g.
 <p data-bbox="186 562 463 619">A minimal weight of air is displaced.</p>	 <p data-bbox="508 590 727 647">Weight of water displaced is 230g.</p>	 <p data-bbox="817 590 1049 647">Weight of salt water displaced is 240g.</p>

Because salt water is denser than pure water the object displaces a greater weight of salt water and, therefore, weighs less.

## 7.2.2 ARCHIMEDES PRINCIPLE AND ITS APPLICATION

### 7.2.2.1 Principle of Archimedes



**Fig.7. 10** The stone weighed 0.67 N in air and 0.40 N when immersed in water. The displaced water weighed 0.27 N (= 0.67 N- 0.40 N).



## Activity 7.8 Experimental Verification of Archimedes principle

With reference to the Table 7.2, do this experiment and answer the questions.

### Materials:

- Dynamometer
- A stone of at least 60 g
- Eureka can and a beaker
- A thread

### Procedure:

1. Place a Eureka can (over-flow vessel) on a table and place a beaker under its spout as shown in figure below.
2. Pour water into the can till the water starts overflowing through the spout.
3. When the water stops dripping replace the beaker by another one of known weight.
4. Suspend a stone with the help of a string from the hook of a spring balance and record the weight of the stone.
5. Now, gradually lower the body into the Eureka can containing water and record its new weight in water when it is fully immersed in water.
6. When no more water drips from the spout, weigh the beaker containing water.
  - Write down the results of the experiment as follows: Weight of the stone in air  $W_a = 0.67 \text{ N}$
  - Weight of the stone in water  $W_f = 0.40 \text{ N}$
  - Weight of the empty beaker = a N
  - Weight of beaker + water displaced = b N
  - Apparent loss of weight of the stone  $= W_a - W_f = 0.67 \text{ N} - 0.40 \text{ N} = 0.27 \text{ N}$
  - Weight of water displaced = (b - a) N

You will notice that  $W_a - W_f = b - a$

Thus, the apparent loss of weight of the body, or the upthrust force also called the buoyancy (B) on the body equals the weight of the water displaced.

$$B = r_f gV = \text{Weight of the displaced fluid}$$

$$B = \text{weight in air} - \text{weight in fluid} = 0.67 \text{ N} - 0.40 \text{ N} = 0.27 \text{ N}$$

The Archimedes principle states that: **“When a body is totally or partially immersed in a fluid it experiences an upthrust force equal to the weight of the fluid displaced.”**

### Example:

A body weighs 450 g in air and 310 g when completely immersed in water. Find

- (i) the loss in weight of the body
- (ii) the upthrust on the body
- (iii) the volume of the body

### Solution:

$$W_a = 0.450 \text{ kg} \times 10 \text{ m/s}^2 = 4.50 \text{ N}$$

$$W_f = 0.310 \text{ kg} \times 10 \text{ m/s}^2 = 3.10 \text{ N}$$

$$a) B = W_a - W_f = 4.50 \text{ N} - 3.10 \text{ N} = 1.4 \text{ N}$$

$$b) \text{The upthrust is the buoyance } B = 1.4 \text{ N}$$

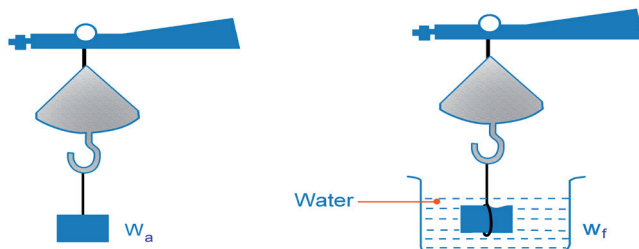
$$c) B = r_f gV$$

$$V = \frac{B}{r_f g} = \frac{1.4 \text{ N}}{1000 \text{ kg/m}^3 \times 10 \text{ m/s}^2} = 0.00014 \text{ m}^3$$

## 7.2.2.2 Some application of Archimedes principle

### 1. Calculation of the Relative Density of a Solid

When a body is immersed in water, it displaces its own volume of water. Upthrust on the body is equal to the weight of this displaced volume of water, which is also equal to loss of weight of the body. Hence ‘weight of equal volume of water’ can be replaced by upthrust or loss of weight in water. Find the weight ( $W_1$ ) of a solid in air using a hydrostatic balance as shown in figure below.



**Fig.7. 11** Measuring relative density of a substance

- Tie the solid with a thread and suspend it from the hook as shown in figure.
- Lower the solid in water as shown and find its weight ( $W_2$ ).
- Weight of the solid in air:  $W_a$
- Weight of the solid in water =  $W_f$
- Apparent loss of weight of solid =  $(W_a - W_f)$

$$RD \text{ or } SG = \frac{W_a}{B} = \frac{W_a}{W_a - W_f} = \frac{m_a}{m_a - m_f}$$

### Example:

A body weighs 600 g in air and 400 g in water. Calculate

- (i) Upthrust on the body,
- (ii) Relative density of the solid.

### Solution

$$W_a = 0.600 \text{ kg} \times 10 \text{ m/s}^2 = 6.0 \text{ N}$$

$$W_f = 0.400 \text{ kg} \times 10 \text{ m/s}^2 = 4.0 \text{ N}$$

$$a) B = W_a - W_f = 6.0 \text{ N} - 4.0 \text{ N} = 2.0 \text{ N}$$

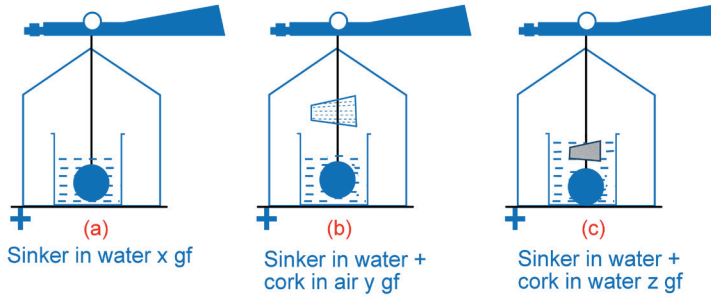
$$b) RD = \frac{W_a}{B} = \frac{6.0 \text{ N}}{2.0 \text{ N}} = 3$$

## 2. Calculation of Relative Density of a Liquid

When a solid body is immersed in a liquid and then in water, the volume of displaced liquid is the same as the volume of displaced water which is equal to the volume of the solid.

- Select a solid (sinker) which is insoluble in the given liquid.
- Weigh the sinker in air.
- Weigh the sinker in water and finally weigh the sinker in the given liquid.





**Fig.7. 12 Experimental calculation of relative density of liquids**

- Record the observations as shown below:
- Weight of the sinker in air  $W_a$
- Weight of the sinker in water  $W_{f1}$
- Weight of the sinker in liquid  $W_{f2}$
- Loss of weight of the sinker in water =  $(W_a - W_{f1})$
- Loss of weight of the sinker in liquid =  $(W_a - W_{f2})$

$$R.D \text{ of the liquid} = \frac{\text{loss of weight of sinker in liquid}}{\text{loss of weight of sinker in water}} = \frac{W_a - W_{f2}}{W_a - W_{f1}} = \frac{m_a - m_{f2}}{m_a - m_{f1}}$$

**Example:**

A solid weighs 600 g in air, 450 g in water and 480 g in a liquid. Find the R.D. of the liquid.

**Solution**

$$W_a = 0.600 \text{ kg} \times 10 \text{ m/s}^2 = 6.0 \text{ N}$$

$$W_{f1} = 0.450 \text{ kg} \times 10 \text{ m/s}^2 = 4.5 \text{ N}$$

$$W_{f2} = 0.480 \text{ kg} \times 10 \text{ m/s}^2 = 4.8 \text{ N}$$

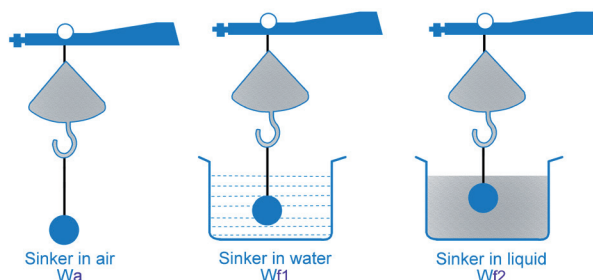
$$RD = \frac{W_a - W_{f2}}{W_a - W_{f1}} = \frac{6.0 - 4.8}{6.0 - 4.5} = 0.8$$

**3. Relative Density of Solids which Float in Water**

Relative density of solids like wax, cork etc. is determined by the following method.

- Choose a sinker and find its weight in water by suspending it in water as shown in figure 7.13 (a) below.

- Tie the solid cork to the string attached to the sinker and find its weight in air but sinker in water as shown in figure 7.13 (b) below.
- Remove the cork and tie it together with the sinker and suspend it in water as shown in figure 7.13 (c) and find the weight of the cork together with the sinker in water.



**Fig.7. 13 Relative density of a floating body**

**Example:**

A wooden block in the form of a cube of side 10 cm is floating in water with 4 cm above the surface of water. If the density of water is  $1 \text{ g cm}^{-3}$ , find the density of wood.

Measuring the relative density of a cork

Weight of sinker in water

Weight of sinker in water + cork in air

Weight of sinker and cork, both in water

Find the R.D and density of cork.

**4. Law of Floatation**

When a floating body like wood is placed in water, it sinks until the weight of water displaced by it is just equal to its own weight and then it floats. This leads us to the principle of floatation: “When a body floats in a fluid, it displaces an amount of fluid equal to its own weight. The apparent weight of a floating body is zero.” The mass of the floating is equal to the mass of the fluid displaced.

Example: A slab of ice of volume  $800 \text{ cm}^3$  and of density  $0.9 \text{ g cm}^{-3}$  floats in water of density  $1.1 \text{ g /cm}^3$ . What fraction of ice is above salt water?

**Solution:**

When a body floats on a liquid, the mass of the body is equal to mass of the fluid displaced.

$$\begin{aligned}
 m_{ice} &= r_{ice} V_{ice} \\
 &= 800 \text{ cm}^3 \times 0.9 \text{ g cm}^{-3} \\
 &= 720 \text{ g}
 \end{aligned}$$

$$m_{\text{water displaced}} = m_{ice} = 720 \text{ g}$$

$$\text{Volume of displaced water } V_{\text{water}} = \frac{m_{\text{water}}}{r_{\text{water}}}$$

$$V_{\text{water}} = \frac{720 \text{ g}}{1.1 \text{ g/cm}^3} = 655.54 \text{ cm}^3$$

The volume of water displaced is equal to the volume of the submerged part of ice.

The fraction is then given by: 
$$\text{fraction} = \frac{V_{\text{submerged part}}}{V_{ice}} = \frac{655.54 \text{ cm}^3}{800 \text{ cm}^3} = 0.82$$

At least 82% of the ice is submerged in water.

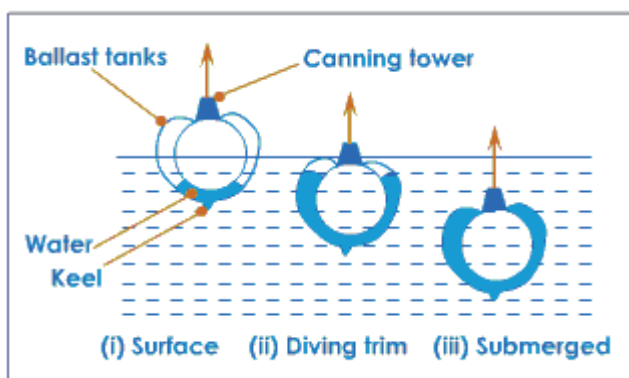
### Checking my progress

- A piece of aluminum of volume  $200 \text{ cm}^3$  and density  $2.7 \text{ g cm}^{-3}$  is completely immersed in kerosene.
  - Determine upthrust exerted on the piece of aluminum
  - Determine how much will it weigh in kerosene. (density of kerosene =  $0.8 \text{ g cm}^{-3}$ )
- Equal volumes of lead and aluminum are submerged in water. Which feels the greatest buoyant force? Explain.
- When placed in a pycnometer,  $20 \text{ g}$  of salt displaces  $7.6 \text{ g}$  of coal oil. If density of coal oil is  $0.83 \text{ g/cm}^3$ , find the volume and density of the salt.
- A solid weighs  $50 \text{ g}$  in air and  $44 \text{ g}$  when completely immersed in water. Calculate
  - R.D of the solid
  - upthrust
  - density of the solid in cgs and SI units.
- Body weighs  $20 \text{ g}$  in air,  $18.2 \text{ g}$  in a liquid and  $18.0 \text{ g}$  in water. Calculate
  - the relative density of the body
  - and relative density of the liquid.

6. A solid weighs 32 g in air and 28.8 g in water. Find how much will it weigh in a liquid of R.D 0.9.
7. A hollow cylinder closed at one end weighs 85 g which floats vertically in water when 35 g of lead shots are added into it. If the depth of immersion is 10 cm, calculate the
  - a) Upthrust acting on the cylinder,
  - b) area of cross section of the cylinder,
  - c) Depth of immersion in a liquid of R.D. equal to 1.2
8. A 70 kg ancient statue lies at the bottom of the sea. Its volume is  $3.0 \times 10^4 \text{ cm}^3$ . How much force is needed to lift it?
9. The mass of a block made of certain material is 13.5 kg and its volume is  $15 \times 10^{-3} \text{ m}^3$ . Will the block float or sink in water? Give a reason for your answer.
10. A slab of ice of volume  $800 \text{ cm}^3$  and of density  $0.9 \text{ g cm}^{-3}$  floats in salt water of density  $1.1 \text{ g / cm}^3$ . What fraction of ice is above salt water?
11. What volume  $V$  of helium is needed if a balloon is to lift a load of 800 kg (including the weight of the empty balloon)?
12. A weather forecasting plastic balloon of volume  $15 \text{ m}^3$  contains Hydrogen of density  $0.09 \text{ kg m}^{-3}$ . The volume of the equipment carried by the balloon is negligible compared to its own volume. The mass of the empty balloon alone is 7.15 kg. The balloon is floating in air of density  $1.3 \text{ kg m}^{-3}$ . Calculate:
  - a) the mass of hydrogen in the balloon
  - b) the mass of hydrogen and the balloon
  - c) the total mass of the hydrogen, the balloon and the equipment if the mass of the equipment is 'x' kg.
  - d) the mass of air displaced by the balloon
  - e) the mass of the equipment using the law of floatation.
13. Hydrometer is a simple instrument used to indicate specific gravity of a liquid by measuring how deeply it sinks in the liquid. A particle hydrometer consists of a glass tube weighted at the bottom, which is 25 cm long,  $2.00 \text{ cm}^2$  in cross-sectional area, and has a mass of 45.0 g. How far from the end should the 1.00 mark be placed?

### 7.2.2.4 Applications of Archimedes principle in real life

#### 1. Submarines



**Fig.7. 14 Submarine**

A submarine (the word submarine was originally an adjective meaning “under the sea”) is made to float or sink by altering the average density. By average density is meant the value obtained by dividing the total mass of the submarine (including air in it, the crew, and so on) by its volume. When submerged, the submarine has an average density equal to that of the water around it. In order to bring it to the surface its mass must be made less and this is done by expelling water from tanks (this is called ballast) situated along the sides of the submarine, replacing the water by compressed air.

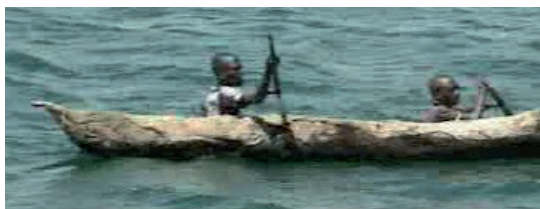
The boat is provided with large ballast tanks which can be filled with water. This increases the weight of the submarine, so that it sinks into the sea, so that it sinks lower.

When the submarine is ready to surface, the rudders are moved to drive the boat upwards, and compressed air is forced into the ballast tanks to drive the water out so that the submarine can rise.

Most of the marine animals also use this principle to remain at a selected level in the sea. For example, fish has an air sac, called a swim bladder in its body. This is filled with air and usually occupies about 5% of its total body volume. Its size is adjusted so that the fish is posed at the depth at which is usually lives and feeds. At that level, the condition of its weight is exactly balanced by the upthrust it experiences.

## 2. Ships

In the case of a ship, its weight is balanced by a buoyant force from the displaced water, allowing it to float. If more cargo is loaded onto the ship, it would sink more into the water - displacing more water and thus receive a higher buoyant force to balance the increased weight



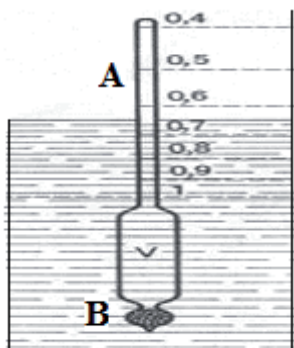
**Fig. 7. 15 Boat in Lake Muhazi**

So, how can objects made of aluminum or iron float? The secret lies in increasing the volume of the displaced water. Although a small cube of iron will immediately sink when placed in water, a large boat can float by adjusting the amount of water it displaces. A sheet of aluminum foil can float when formed into a “barge” with a large surface area whereas the same size sheet will immediately sink when crushed. In all cases, you are reducing the density by increasing the volume.

### Did you know?

- Boats float higher in salt water than they do in fresh water.
- Some liquids sink in other liquids.

## 3. Densimeter (Hydrometer bottom)



**Fig.7. 16 Hydrometer**

An aerometer, is a scientific instrument used to measure the weight and specific gravity of a gas or liquid in which it floats. It is a hollow

tube, widened at the bottom where a weight is placed (B). A scale is present on the upper part of the rod. The aerometer is placed in the liquid needing to be tested. The scale (A) will be held upright by the weight in the lower part (B). The specific gravity of the liquid is read where the scale penetrates the surface of the liquid.

### Lactometer

It is special type of hydrometer used for testing the purity of milk or to check richness of milk. It has a range of relative density 1.105 to 1.045.

### Battery Hydrometer

It is used for measuring the relative density of accumulator acid. It is kept inside a glass tube fitted with a rubber bulb at the upper end. The lower end of the glass tube is connected with a narrow tube which is made of acid resistant material. When in use, this end is submerged in the acid in the accumulator. The acid in a fully charged cell should have a relative density of 1.25 to 1.30. A reading of less than 1.18 indicates that recharging is necessary.

## 7.3 APPLICATION OF ARCHIMEDES PRINCIPLE IN AIR



### Activity 7.9: Investigating air pressure effect on a balloon

#### Materials:

- Balloon(s)
- Pump

#### Procedure:

- Pump air in the balloon
- Let it fly in air and write down the observation made.

#### Questions:

1. What is pushing up the balloon?
2. Why is the balloon not falling down easily like other bodies do (like stones)?
3. Comment on common observations you have made in real life where this case may be observed.

### 7.3.1 Rigid Airships

Semi-rigid airships were more popular earlier this century. They usually comprise a rigid lower keel construction and a pressurized envelope above that. The rigid keel can be attached directly to the envelope or hung underneath it. The airships of Brazilian aeronaut Alberto Santos-Dumont were of this type. One of the most famous airships of this type was Italia, used by General Umberto Nobile in his attempt to reach the North Pole.



**Fig.7. 17 Semi rigid airship**

### 7.3.2 Non-rigid Airships

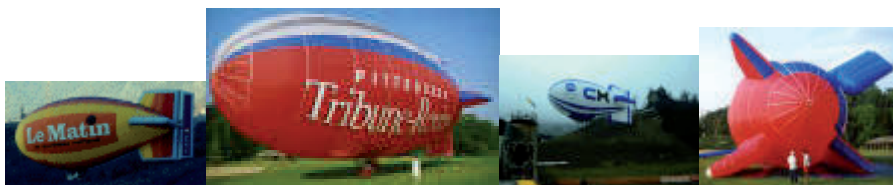
Non-rigid airships, also known as Blimps, are the most common type nowadays. They are large gas balloons whose shape is maintained only by their internal overpressure. The only solid parts are the passenger car and the tail fins. All the airships currently flying for advertisement purposes are of this type; the Goodyear Blimps, the Budweiser and the MetLife Blimps in the USA, and the Fuji Blimp in Europe.



**Fig.7. 18 Non rigid airship**

### 7.3.3 Hot Air Airships

Hot air airships, also known as thermal airships, are counted as a fourth kind although they are technically part of the non-rigid category. Hot air airships are derived from traditional hot air balloons. Early models were almost like balloons with an engine and tail fins added. Later, the envelopes were lengthened and the tail fins and rudder were pressurized by air from the wash of the propeller. Newer hot air airships maintain their shape with internal overpressure in the whole envelope, a feature which older models did not have.



**Fig.7. 19 Hot air Airship**



## 7.4 Unit 7 Assessment

1. Discuss other applications of Archimedes principle that are in use today.
2. Discuss how these methods might be useful in finding mass and volume rather than by direct measurement.
  - a) Using Archimedes Principle to Measure Mass of an object immersed in a fluid of known density (If an object is immersed completely it will displace its volume.)
  - b) Archimedes principle allows us to calculate the mass of floating objects (If an object is floating, the mass of the displaced water is equal to the mass of the block).
3. A cubical block made of a certain type of plastic has a density of  $0.75\text{g/cm}^3$ . The density of water is  $1.0\text{g/cm}^3$ . If the block is allowed to float in water, what fraction of the volume of the block would be below the water level?
  - a) one quarter
  - b) one half
  - c) three quarters
  - d) some other fraction
4. The density of aluminum is about 2.7 times greater than that of water, so a block of aluminum will sink when placed in water. How is it possible to build a boat in the figure below using only aluminum?



**Fig. 7.23:** A Sailing boat in lake Kivu

5. A glass beaker is filled with water and placed on a balance. A person holds a finger into the water. The reading on the balance will;
  - a) go up
  - b) go down
  - c) stay the same
  - d) Can't tell

---

# **Mechanics**

## Work, Power and Energy

---



# Unit 8

## Work, Power and Energy

### Key unit competence

---

By the end of this unit, I should be able to relate work, power and energy.

### My goals

---

By the end of this unit, I will be able to:

- Apply the knowledge on energy, work and power and explain the terms work, power and energy.
- Explain the relationship between work, power and energy
- Derive the equations relating work and power.
- Understand the importance of energy and power for efficiency working of machines.
- Show concern of work as a product of distance and energy.
- Be aware of the social, economical, environmental and technological implications of studying work energy and power.
- Develop an analytical mind to critically evaluate work, energy and power.

### Key concepts

---

1. How are work, energy and power realised or manifested in our daily life?
2. How can one relate work, energy and power?
3. Discuss the difference between potential energy and Kinetic energy.
4. Discuss different areas where Potential energy and Kinetic energy can be observed.
5. How can you compare the people's power?



## Vocabulary

Work, energy, power, Potential energy, Kinetic energy, Mechanical energy, Energy conservation.



## Reading strategy

Draw a diagram which can help you to define work and energy in your own words. After you read each section, compare your definition to the scientific definition and explain where work and energy may be observed useful in life. Identify several activities you have learned that are relevant to your life, explain why they are relevant to you. (8.1). Relating Work, Energy and Power

## 8.1 Relating Work and Energy



### Activity 8.1: Investigating the work done when lifting a box

#### Materials:

- Box of 2kg mass.
- A table of at least 1.5m high.

#### Procedure:

- Lift the box and take it on the table.
- Take the box down.

#### Questions:

1. Compare the effort that you apply to lift up the box and that when you take the box down.
2. In which case do you require more energy?

In this example work has been done against the force of gravity. Work done, **force** used and **distance** moved by an object in the direction of the force are related as follows:

**Work is defined as using a force to move an object through a distance.**

$$W = F \cdot d$$

**The work** done by the force is defined to be the product of a component of the force in the direction of the displacement and the magnitude of this displacement.

The SI unit of work is the **Joule**, which is the work done when a force of 1N acts through a distance of 1m. Thus:  $1\text{J} = 1\text{ Nm}$ . (In honour of British physicist James Prescott Joule: 1818–1889)

**Example:** Starting from rest, you push your 1000kg car over a 5m distance, on a horizontal ground, when applying horizontal 400N force. What is the work done on the car?

**Answer:**

The work done on the car,  $W = F \times d = 400\text{ N} \times 5\text{ m} = 2000\text{J}$

### Different forms of Work

- Positive work when the direction of motion and that of the force are the same. For example when a person is pushing a car, he does a positive work.
- When the direction of motion is opposite to the direction of the force, the work is negative. Examples; when a stone is thrown up vertically, the work of the force of gravity is negative.
- The work is zero when the displacement is zero despite of the action of the force.

**Example:**

When a person tries to move a lorry and remains at rest, that person has done zero work.

Since **energy** is the capacity to do work or transfer of heat energy, it has the same units as work and heat [**Joule**].

Whenever work is done; energy is transferred or converted from one form to another. Work is performed not only in motion and displacement (mechanical work); it is done also by fire flame and electricity in electric lamps for instance.

## Checking my progress

1. Define work
2. Discuss the relationship between work and energy. Are there any differences? Explain
3. A crate of mass 50kg is pushed along a floor with a force of 20N for a distance of 5m. Calculate the work done.
4. How far must a 5N force pull a 50g toy car if 30J of energy are transferred?
5. A man exerts a force of 2kN on a boulder but fails to move it. Calculate the work done.

## 8.2 Power



### Activity 8.2: Investigating power of a cyclist



**Fig. 8.1:** Tour du Rwanda: Areruya wins 'Nyungwe Challenge'

Take the case of Tour du Rwanda, on 17<sup>th</sup> October 2016 in the step of Rusizi- Huye of a distance equal to 140.7km, in which the winner was the Rwandan cyclist Areruya Joseph who came first in Huye Town.

#### Questions:

Answer true or false and then, explain your argument.

1. Did Joseph A. have more force than others?
2. Was Joseph's average kinetic energy more than that of the other?
3. Which physical quantities were very big for Joseph than others?

The rate of doing work is called power or the rate at which work is done or energy is transferred is called power.  $P = \frac{W}{t}$

The SI unit of power is the Watt (or J/s).in honor of James Watt (1736-1819). Thus  $1W = 1J /s$

An imperial unit called the horsepower (hp) is sometimes used in commercial language:  $1\text{hp} = 736\text{W} = 0.736\text{kW}$ . The units of power can be used to define new units of work and energy. The kilowatt-hour (kWh) is the usual commercial unit of electrical energy. One kilowatt-hour is the total work done in 1 hour (3600s) when the power is 1 kilowatt ( $10^3\text{ J/s}$ ), So  $1\text{kWh} = (10^3\text{ J/s})(3600\text{s}) = 3.6\text{MJ}$

The kilowatt-hour is a unit of work or energy, not power. Our electricity bills carry the energy consumption in units of kWh.

### Checking my progress

1. A force of 20N pushing an object 5m in the direction of the force. How much work is done?

Please enter your answer in the space provided:

joules

2. If you do 100 joules of work in one second (using 100 joules of energy). How much power is used?

watts

3. 1 horsepower is equal to how many watts?

watts

## 8.3 Categories of energy in our environment

There are several forms of energy in our environment such as heat energy, light energy, electric energy, nuclear energy, sound energy, chemical energy stored in petrol, food and other materials, mechanical energy in moving matter such as water, wind, falling rocks, etc.

Scientists classify forms of energy into two major categories: Potential energy and Kinetic energy.

### 8.3.1 Potential energy



#### Activity 8.3: Investigating potential energy in an arc

Carefully study the following photo in Fig. 8.2; in pairs and try to make an arc. Answer the following questions and explain your answers.

##### Questions:

- Where does the energy stored in the arc come from?
- Which type of energy is stored there?
- Where is such energy useful?



**Potential energy** may be defined as the energy possessed by objects or bodies due to their position or state of strain or the position of their parts. **Potential energy is energy deriving from position.** Potential energy is referred to as stored energy because it can be looked at as energy which will be used when time comes for it to be used.

**Potential energy** is the stored energy in an object due to its position with respect to some reference (Normally ground).

**Fig. 8.2:** Potential energy stored in the arrow by the arc

**Potential Energy Formula** is given by

$$P. E = m \times g \times h$$

Where  $m$  is the mass of the body,  $h$  is the height attained due to the body's displacement and  $g$  is the acceleration due to gravity which is constant on earth. Potential energy formula helps to calculate the mass, height or potential energy if any of the two quantities are given. It is expressed in **Joules**.

##### Examples 1.

- A stretched rubber band has elastic potential energy.
- Petrol, coal or food has energy in their chemical bonds, which is called chemical potential energy.

This energy is released when the bonds are broken. Chemical potential energy in petrol is converted to thermal energy when it is burnt in the engine and this used to move vehicles. The energy which we use to carry



out the daily activities from the food we eat is stored (as chemical energy) in the molecules of food such as carbohydrates, proteins and fats. During respiration, some of these molecules are broken down in the cells of the body.

**Example 2:** A ball of mass 2kg is kept on the hill of height 3km. Calculate the potential energy possessed by the ball.

**Answer:** Mass of the body ( $m$ ) = 2kg, Height ( $h$ ) = 3km,

Potential Energy possessed by the body =  $m \times g \times h$

Where  $g = 9.8 \text{ m/s}^2$

$\therefore$  Potential Energy =  $(2\text{kg}) \times (9.8\text{m/s}^2) \times (3 \times 1000\text{m}) = 58800\text{J}$ .

### 8.3.2 Kinetic energy



#### Activity 8.4: Investigating Kinetic energy of a moving body

Study the Fig. 8.3 in order to answer the following questions.

##### Questions:

1. If the car and the motorcycle have the same velocity; which one has more energy? Why?
2. Which type of energy do they possess?
3. Discuss other cases where this form of energy is involved.

Kinetic energy is the form of energy possessed by moving bodies like in Fig. 8.3 where the lorry and the motorcycle are moving on a horizontal road. Such bodies have the ability to do work.



**Fig. 8.3:** The Kinetic energy of a moving body depends on its mass and velocity

##### Examples:

- A flying bullet can kill an animal.
- Wind (a moving mass of air,
- Flowing streams,
- Falling rocks,
- Electricity (flowing electrons),
- Moving cars,

- Lorries,
- Buses, etc,

All have kinetic energy. Kinetic energy of a body is dependent upon both the body's mass and speed. In mechanics, for a point particle, it is mathematically defined as the amount of work done to accelerate the particle from zero velocity to the given velocity;

$$\text{Kinetic Energy } E_k = \frac{1}{2} mv^2$$

In physics, **mechanical work** is the amount of energy transferred by a force acting through a distance. If a force  $F$  is applied to a particle that achieves a displacement  $S$ , the work done by the force is defined as the product of force and displacement:  $W = F.S$

If the mass of the particle is constant, and  $W_{\text{total}}$  is the total work done on the particle obtained by summing the work done by each applied force, from Newton's second law:  $W_{\text{Total}} = E_k$  where,  $E_k$  is called the kinetic energy. Like energy, it is a **scalar** quantity, with **SI units of joules**

- If the force and the displacement are parallel and in the same direction, the mechanical work is positive.  $W = Fd$
- If the force and the displacement are parallel but in opposite directions (i.e. antiparallel), the mechanical work is negative.
- However, if the force and the displacement act perpendicularly to each other, zero work is done by the force:  $W = 0$

According to the **work-energy theorem** if an external force acts upon a rigid object, causing its **kinetic energy** to change from  $E_{k1}$  to  $E_{k2}$ , then the mechanical work ( $W$ ) is given by:

$$W = \Delta K = K_2 - K_1 = \frac{1}{2} mv_f^2 - \frac{1}{2} mv_i^2$$

Where  $m$  is the mass of the object and  $v$  is the object's **velocity** and  $\Delta K$  is the change in Kinetic energy. It can be stated in words:

***The net work done on an object is equal to the change in its kinetic energy.***

**Example 1 :** A 145g baseball is thrown with a speed of 25m/s.

- What is its kinetic energy?
- How much work was done on the ball to make it reach this speed, if it started from rest?

**Answer:**

- The kinetic energy is  $E_k = \frac{1}{2} mv^2 = 45\text{J}$
- Since the initial kinetic energy was zero, the net work done is just equal to final kinetic energy, 45J.

## Checking my progress

1. How much work is required to accelerate a 1000kg car from 20 m/s to 30 m/s?
2. The Moon revolves around the Earth in a circular orbit, kept there by the gravitational force exerted by the earth. Does gravity do:
  - a) positive work,
  - b) negative work, or
  - c) no work at all on the Moon?
3. A football of mass 2.5kg is lifted up to the top of a cliff that is 180m high. How much potential energy does the football gain?
4. A man exerts a force of 2kN on a boulder but fails to move it. Calculate the work done.

## 8.4 Relation between work, energy and power

$$\begin{aligned}
 P &= \frac{W}{t} = \frac{F \times d}{t} \\
 &= F \times \frac{d}{t} \\
 &= F \times v \\
 &= Fv
 \end{aligned}$$

Thus the power associated with force  $F$  is given by  $P = F.v$  where  $v$  is the velocity of the object on which the force acts. Power developed or rate of doing work is obtained by dividing work done by time taken for the flight (climbing) i.e  $P = \frac{w}{l} = \frac{w \times h}{l}$

### Example:

A motor has to move a fully load at a steady speed of 3 m/s. The load has a mass of 1850kg (ignore friction). What is the minimum power of the motor to raise the load at a steady speed?

### Solution:

As the motor moves a load at a steady speed, means that the effort balances with the load.

$$\begin{aligned}
 F &= \text{weight of the load} = m \times g \\
 &= 1850 \text{ kg} \times 10 \text{ m/s}^2 = 18500 \text{ N} \\
 P &= Fv = 18500 \text{ N} \times 3 \text{ m/s} = 55500 \text{ W}
 \end{aligned}$$

## 8.5 Measure personal power



### Activity 8.5: Finding your power



**Fig. 8.4:** Determining personal power

A flight of stairs, preferably straight, is needed for this experiment. The time taken to ascend a known height is measured, and calculation leads to an estimate of human personal power.

1. Measure your own mass using a bathroom scale or any other suitable scale and calculate your weight.
2. Have a friend use a stopwatch to measure the time you take to run up a flight of stairs.
3. Count the number of steps, measure the height of each, and calculate the total height climbed.
4. Calculate the work done in climbing the stairs (work = force  $\times$  distance).
5. Finally, calculate the work done per second (i.e., the power at which you were working when climbing the stairs).

#### For example:

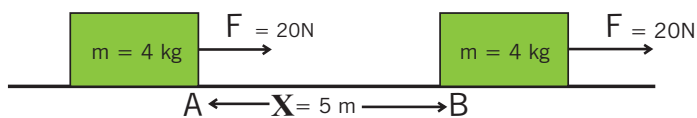
Anna and Tom decide they are going to work out; how much energy is needed to get upstairs. They measure the height of one step and find it is 20cm or 0.2m high. There are 14 stairs altogether so the total height is:  
 $14 \times 0.2 = 2.8\text{m}$ . Anna weighs 500N so the total energy needed for her to climb the stairs is:  
 Energy =  $2.8 \times 500 = 1400\text{J}$ . So the energy needed is 1400J whether Anna runs or walks up the stairs. Tom times Ann walking up the stairs. It takes her 10 seconds, so Ann's power is:  
 Power =  $1400 / 10 = 140\text{Watts}$

Ann returns downstairs, then Tom times her running upstairs. This time she gets there in 3 seconds, so her power is:

$$\text{Power} = 1400 / 3 = 467\text{Watts}$$

## 8.6 Unit 8 assessment

- A 7.00kg bowling ball moves at 3.00m/s. How much kinetic energy does the bowling ball have? How fast must a 2.45g table-tennis ball move in order to have the same energy as the bowling ball?
- A 193kg curtain needs to be raised 7.5m in as close to 5.0s as possible. Three motors are available. The power ratings for the three motors are listed as 1.0kW, 3.5kW, 5.5kW. Which motor is best for the job?
- Starting from rest, you push your 1000kg car over a 5m distance, on an horizontal ground, applying a horizontal 400N force.
  - What is the car kinetic energy change?
  - What is its final velocity at the end of the 5 meters displacement? Disregard any friction force.
- Define (a) Energy, (b) Kinetic energy, (c) Potential energy and (d) Power.
- A lorry tows a trailer of mass 1800kg at a speed of 45 km/h along a straight road. If the tension in the coupling is 900N, find the power expended by the lorry's engine.
  - If the trailer is pulled along a stretch of 800m at a new speed of 60km/h, find the new power output required to create a tension of 1200N in the coupling.
- A 5.2kg object speeds up from 3.1m/s to 4.2m/s. What is the change in Kinetic energy?
- A 1.2 HP motor (1 HP = 745.7W) is used to raise a 1300kg Land Rover 5.7m up into a tree. What time will it take?
- In the picture given below, F pulls a box having 4kg mass from point A to B. If the friction constant between the surface and the box is 0,3; find the work done by F, work done by friction force and work done by the resultant force.



- A lift motor has to move a fully laden lift 4m between floors in 1.5s. The lift has a mass of 1850kg (ignore friction).a) Calculate the weight of the fully laden lift; b) What is the upward force in the cable when the lift is moving at a constant speed?;c) What is the work done by the motor?;d) What is the minimum power of the motor to raise the lift at a steady speed?
- How fast is a trolley moving if it has 180.5J of kinetic energy?





# Unit 9

## Conservation of Mechanical Energy in Isolated System

### Key unit competence

By the end of this unit I should be able to apply the principle of conservation of mechanical energy for isolated system.

### My goals

By the end of this unit, I will be able to:

- Define terms associated with isolated system and open system.
- Describe an isolated and open system.
- State different forms of mechanical energy.
- Differentiate kinetic from potential energy.
- State principle of the conservation of energy.
- Identify different forms of mechanical energy.
- Apply the principle of conservation of mechanical energy in solving problems.
- Discuss applications of the principle of conservation of mechanical energy to isolated system.
- Understand the application of the principle of conservation of mechanical energy.
- Explain that kinetic energy can be converted into potential energy and vice versa.
- Predict the consequences of the law of conservation of mechanical energy on an isolated system

## Key concepts

1. How one can define a system and energies that are involved in.
2. How energy of a system is conserved.
3. Discuss the mechanical energy conversion process and its conservation.
4. Discuss different application of energy conservation law.



### Vocabulary

Energy conservation, isolated system, open system, closed system.



### Reading strategy

When reading this section, take note of the definitions of key terms. Explain the key terms in your own words and try to perform calculations involving energy conservation in a system. Exercise doing calculations regularly until they are grasped fully.

## 9.1 Isolated and open systems



### Activity 9.1: Investigating the open and closed system

#### Materials:

- |                  |                 |
|------------------|-----------------|
| ● Vacuum flask   | ● Bunsen burner |
| ● Cooking vessel | ● Thermometer   |
| ● Tripod stand   | ● Stop watch    |

#### Procedure:

- Place the cooking vessel on top of the lite Bunsen burner
- Heat water in the cooking vessel on the tripod stand until it is boiling and record the time taken for the water to boil using your stopwatch.
- Measure the temperature of the boiling water.
- After the water has boiled, pour part of it into the vacuum flask and close it, then leave another part in the cooking vessel.
- Remove the cooking vessel and the boiling water from the Bunsen burner.
- Leave the water in the flask and that in the cooking vessel for a period of 20 min.

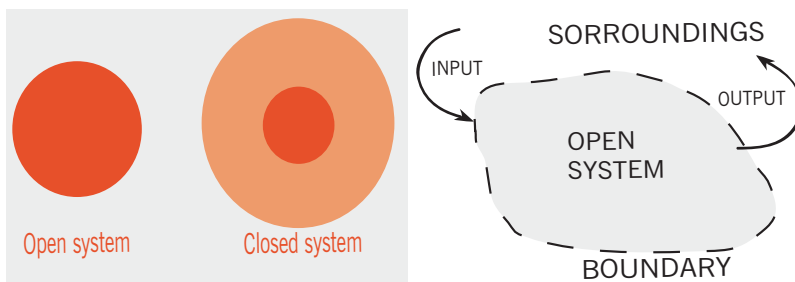


- Measure the temperature of the water in the vacuum flask  $t_1$  after those 20 min.
- Measure the temperature of water in the cooking vessel  $t_2$  after those 20 min.

### Questions:

1. Compare the two temperatures  $t_1$  and  $t_2$  and discuss the results obtained.
2. Why are the results different?
3. What is the difference between the vacuum flask system and the cooking vessel system of keeping the temperature?

An isolated system referred to as closed system is a physical system that does not allow certain types of transfers (such as transfer of energy or mass) in or out of the system. The specification of what types of transfers are excluded varies in the closed systems of physics, chemistry or engineering.



**Fig. 9.1:** Closed and Open system

In thermodynamics, a closed system can exchange energy (as heat or work) but not matter, with its surroundings. An isolated system cannot exchange any heat, work, or matter with the surroundings, while an open system can exchange energy and matter. In particular, some writers use 'closed system' where 'isolated system' is here used. For a simple system, with only one type of particle (atom or molecule), a closed system amounts to a constant number of particles.

An **open system** is a system that has external interactions. Such interactions can take the form of information, energy, or material transfers into or out of the system boundary, depending on the discipline which defines the concept. An open system is contrasted with the concept of an isolated system which exchanges neither energy, matter, nor information with its environment. An open system is also known as a constant volume system or a flow system.

## 9.2 Kinetic and potential energy of a system



### Activity 9.2: Investigating Kinetic energy and Potential energy of a system

With reference to the activity 8.2 and the Fig.8.2; try to answer the following questions in pairs;

**Questions:**

1. Name the energies that are involved in the system (Fig. 8.2).
2. Discuss and explain the energy relationship in the system.

**Kinetic energy** is directly proportional to the mass of the object and to the square of its velocity:

$$K.E = \frac{1}{2} mv^2$$

If the mass has units of kilograms and the velocity of meters per second, the kinetic energy has units of kilograms-meters squared per second squared. Kinetic energy is usually measured in units of Joules (J); **one Joule** is equal to 1kg m<sup>2</sup>/s<sup>2</sup>.



### Activity 9.3: Quick exercise

Calculate the kinetic energy in Joules possessed by each of the following objects. Remember to use the correct number of significant figures in your answer.

A. A 500g wooden block moving at 2m/s.	<input type="text"/>	J
B. A 71kg man walking at 1.0m/s.	<input type="text"/>	J
C. A 71kg man running at 5.0m/s.	<input type="text"/>	J
D. A 1816kg car travelling at 26.8m/s	<input type="text"/>	J

**Potential energy** is the energy an object has because of its position relative to some other object. When you stand at the top of a stairwell you have more potential energy than when you are at the bottom, because the earth can pull you down through the force of gravity, doing work in the process. The formula for potential energy is derived from the two factors affecting PE, which are the force acting on the two objects (weight) and height of the object from the ground level.

$$P.E = mgh$$

Where  $m$  is the mass in kilograms,  $g$  is the acceleration due to gravity ( $9.8\text{m/s}^2$  at the surface of the earth) and  $h$  is the height in meters. Notice that gravitational potential energy has the same units as kinetic energy,  $\text{kgm}^2/\text{s}^2$ . In fact, all energy has the same units,  $\text{kg m}^2/\text{s}^2$ , and is measured using the unit Joule (J).

### Example

John has an object suspended in the air. It has a mass of 50 kilograms and is 50 meters above the ground. How much work will be done by gravity when the object is dropped?

### Answer:

$$m = 50\text{kg}, g = 9.8\text{m/s}^2, h = 50\text{m}$$

Where the Work done on the object was converted to Potential energy.

$$PE = mgh = 50\text{kg} \times 9.8\text{m/s}^2 \times 50\text{m} = 24500\text{J}$$

## 9.2.1 Kinds of potential energy

### a) Chemical potential energy

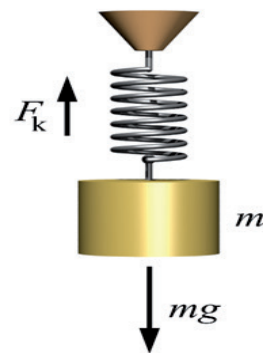
Activities such as tug of war or riding a bicycle, make us use energy provided by the food we eat. In cars or motorcycles, petrol is used to provide energy. Petrol contains energy which makes these vehicles move. Food and petrol contain energy called chemical potential energy. It is called chemical energy because it is from the chemical bonds found in the food or petrol and also called potential energy because it is potentially available for use when it is needed.

### a) Chemical potential energy



**Fig. 9.2:** Potential energy between Na atom and Cl

### b) Elastic potential energy



**Fig. 9.3:** Spring hang on retort stand



### Activity 9.4: Investigating elastic potential energy

**Materials:**

- Spring or dynamometer
- Rotor stand set
- Slotted mass (50g or 100g)
- Mass hanger (50g or 100g)

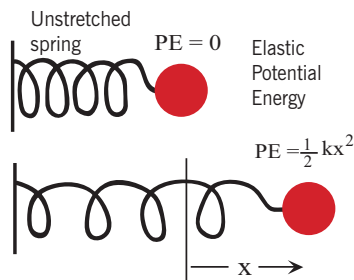
**Procedure:**

- Fix the retort stand
- Hang the spring on the retort stand
- Hang the mass hanger on the spring
- Put different slotted mass on the mass hanger in order of 100g, 200g, 300g etc

**Questions:**

1. What is happening on the spring as masses are being added to the mass hanger?
2. “If the masses were removed, what would happen to the spring? Explain which energy helps for that to happen”

A catapult is used to hurl a stone at a high speed by stretching its bands and then releasing them to hurl the stone. The catapult possesses elastic potential energy when its bands are in the condition of being stretched, which is then transferred to the stone and makes it move at high speed.



When the bands are not stretched there is no potential energy in them. The potential energy contained in a stretched rubber band is called elastic potential energy:  $PE_{elastic} = \frac{1}{2} kx^2$  where  $k$  is called the elastic constant and  $x$  is the stretched distance.

**Fig. 9.4:** Elastic potential energy

## c) Gravitational potential energy



### Activity 9.5: Investigating gravitational potential energy

#### Materials:

A ball

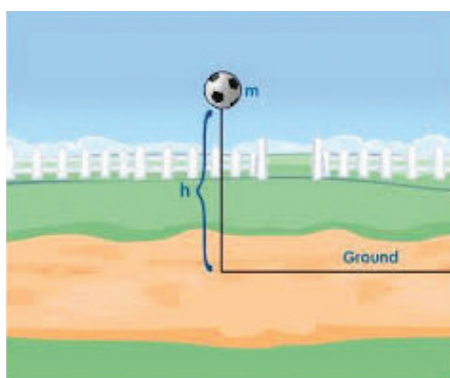
#### Procedure:

Throw the ball vertically upward such that it reaches a noticeable height as shown in Fig. 9.5.

#### Questions:

1. Describe the energy that made the ball to fly upward.
2. Why does the ball return down immediately after reaching maximum height?
3. Which kind of energy does the ball have at the top of its path?

An object raised to a height has energy due to the position it is at. An object raised to a higher level has more gravitational potential energy. If an object such as a hammer or a brick which was placed on a table top is let to fall, it can break something which is placed in its way or it can hurt someone whose foot is in its way because the potential energy which was stored in it is changed into motion (kinetic) energy which is used to break something or hurt someone in its way. More work is done in raising a brick to a higher level hence more gravitational potential energy is stored in the brick at a higher level.



**Fig. 9.5:** Potential energy in the ball

The gravitational potential energy of a mass  $m$ , at a height  $h$ , is:

$$PE = mgh$$

This expression can be derived as shown below: suppose a mass  $m$  (weight =  $mg$ ) is raised through a vertical height  $h$ , the work done is:  $W = mgh$

### 9.2.3 Conversion of potential energy into kinetic energy



#### Activity 9.6: Investigating energy conversions on cyclists

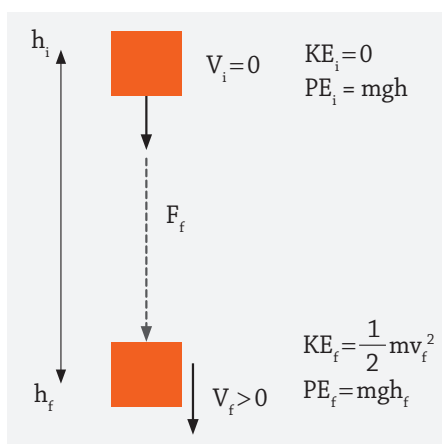
Look at this photo (Fig. 9.6) of cyclists in Tour du Rwanda step of MUSANZE-KIGALI. As the cyclists were going downhill, explain and describe how the potential energy is being converted to Kinetic energy.



**Fig. 9.6:** Potential energy stored in a cyclist when going downhill.

Kinetic energy is the energy possessed by a moving object. That is energy gained by a body due to virtue of its motion. It generally comes into picture when some work is done onto the body to set it in motion. We calculate it as  $KE = \frac{1}{2} mv^2$ .

Potential energy is the energy stored within a physical system as a result of the position or configuration of the different parts of that system. It has the potential to be converted into other forms of energy such as kinetic energy and to do work in the process.  $PE = mgh$  (h is the height of the body from reference point). When no other form of energy is created or lost in motion of a body, then from the law of Conservation of energy we can say that the Potential energy of a body converts to Kinetic Energy.



**Fig. 9.7:** Change of Potential energy into Kinetic energy and conservation of mechanical energy

Considering the diagram above, at the highest point the block has Potential energy. If we suppose it was dropped from rest, then its Kinetic energy at that point was zero. At that instant :

$$\text{K.E} = \frac{1}{2} mv^2 = 0 \text{ and } \text{PE} = mgh$$

Here  $m$  is the mass of the body,  $g$  is acceleration due to gravity,  $h$  is the height,  $v$  is the velocity of the body. When the block comes to the lowest point which is ground, all its Potential energy is converted to Kinetic energy. That's the reason why the velocity of falling objects keeps on increasing and hits the ground with great impact.

### Checking my progress

- When you are boiling soup in an open saucepan on a stove, energy and matter are being transferred to the surroundings through steam. Which type of system is this?
- Calculate the kinetic energy of a ball of mass  $0.18\text{kg}$  kicked by Jenas at a velocity of  $12\text{m/s}$ 
  - $12.96\text{ mJ}$
  - $13.0\text{ J}$
  - $12.0\text{ J}$
- Walter walls from a cliff of height of  $12\text{m}$  from water level during his diving exercises. Calculate his speed of contact with water. (Take acceleration due to gravity to be  $9.8\text{N/kg}$ )
  - $12\text{m/s}$
  - $15.3\text{m/s}$
  - $9.8\text{ m/s}$

4. When a ball is dropped from a height of 5.0m, it lands on the stationary ground and bounces back, .....
- It can even rise to beyond the original height.
  - It will never go beyond the original height.
  - Its energy will always be lost to heat and elastic potential energy.
  - Friction will cause the ball not to bounce any height.

### 9.3 Mechanical energy

Kinetic energy is  $K.E = \frac{1}{2} mv^2$ ; then potential energy is just  $PE = mgh$

Where  $g$  is the gravitational field strength and  $h$  is the position in height.

They are actually very closely related. In fact, the potential energy plus the kinetic energy due to the force is a constant. When potential energy decreases at exactly the same rate, it implies the increases in kinetic energy.

**This is the conservation of energy.** In fact, since the particles are moving at finite velocities, this is the much stronger local conservation of **energy for mechanical systems**. We may concisely state the following principle, which applies to closed systems (i.e. when there are no interactions with things outside the system).

### 9.4 Law of conservation of energy

This law states that: ***“in all energy conversions or transformations, energy is neither created nor destroyed, but it may be converted from one form to another but the total amount remains constant.”***

This means that energy does not disappear but is either transferred to another place or transformed (changed) into some other form. This law tells us when one form of energy is converted to another form during an energy conversion, energy in put always equals energy out.

The law of conservation of energy can also be stated as follows: **“during transformation of energy from one form to another, the total amount of energy is unchanged i.e. the amount of the new form which appears is equal to the amount of the old form which disappeared”**

**In all physical processes taking place in closed systems, the amount of change in kinetic energy is equal to the amount of change in potential energy. If the kinetic energy increases, the potential energy decreases, and vice-versa.**



When we consider open systems (i.e. when there are interactions with things outside the system), it is possible for energy to be added to the system (by doing work on it) or taken from the system (by having the system do work). In this case the following rule applies:

**The total energy of a system (kinetic plus potential) increases by the amount of work done on the system, and decreases by the amount of work the system does.**

A conservation law, in its most general form, simply states that the total amount of some quantity within a closed system doesn't change. For instance, the conserved quantity would be socks, the system would be the dryer, and the system is closed as long as nobody puts socks into or takes socks out of the dryer. If the system is not closed, we can always regard a larger system which is closed and which encompasses the system we were initially considering (e.g. the house in which the dryer is located), even though, in extreme cases, this may lead us to consider the amount of socks (or whatever) in the entire Universe!

Within a closed system, the total amount of energy is always conserved. This translates as the sum of the  $n$  changes in energy totalling to 0.

An example of such a change in energy is dropping a ball from a distance above the ground. The energy of the ball changes from potential energy to kinetic energy as it falls.

$$P.E = mgh$$

$$K.E = \frac{1}{2} mv^2$$

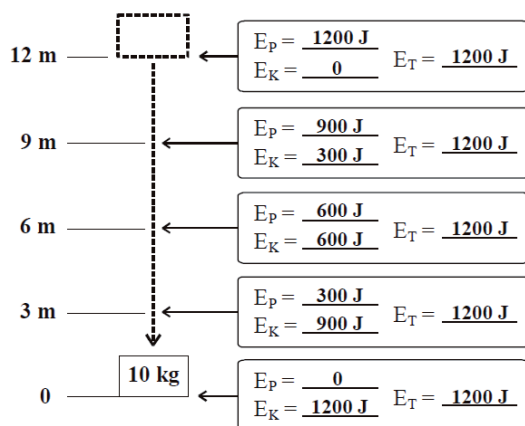
In the physical sciences, **mechanical energy** is the sum of potential energy and kinetic energy.

$$ME = KE + PE$$

It is the energy associated with the motion and position of an object. The principle of conservation of mechanical energy states that in an isolated system that is only subject to conservative forces, the mechanical energy is constant. If an object is moved in the opposite direction of a conservative net force, the potential energy will increase and if the speed (not the velocity) of the object is changed, the kinetic energy of the object is changed as well. In all real systems, however, non-conservative forces, like frictional forces, will be present, but often they are of negligible values and the mechanical energy's being constant can therefore be a useful approximation. In elastic collisions, the mechanical energy is conserved but in inelastic collisions, some mechanical energy is converted into

heat. The equivalence between lost mechanical energy (dissipation) and an increase in temperature was discovered by James Prescott Joule. Many modern devices, such as the electric motor or the steam engine, are used today to convert mechanical energy into other forms of energy, e.g. electrical energy, or to convert other forms of energy, like heat, into mechanical energy.

**Example:** A 10kg object falls from a height of 12m. Fill in the potential, kinetic and total energy of the object at the given points.

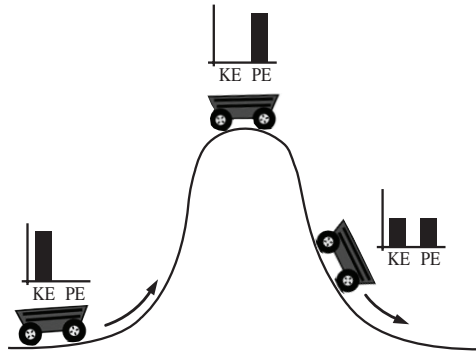


### 9.5 Applications of law of conservation of mechanical energy

In physics, if you know the kinetic and potential energies that act on an object, then you can calculate the mechanical energy of the object. Imagine a roller coaster car traveling along a straight stretch of track. The car has mechanical energy because of its motion: *kinetic energy*. Imagine that the track has a hill and that the car has just enough energy to get to the top before it descends the other side, back down to a straight and level track (Fig. 9.8). What happens?

Well, at the top of the hill, the car is pretty much stationary, so where has all its kinetic energy gone? The answer is that it has been converted to *potential energy*. As the car begins its descent on the other side of the hill, the potential energy begins to be converted back to kinetic energy, and the car gathers speed until it reaches the bottom of the hill. Back at the bottom, all the potential energy the car had at the top of the hill has been converted back into kinetic energy. An object's mechanical potential energy derives from work done by forces, and a label for a particular potential energy comes from the forces that are its source. For example, the roller

coaster has potential energy because of the gravitational forces acting on it, so this is often called *gravitational potential energy*.



**Fig. 9.8:** The change of potential energy to kinetic energy, the conservation of mechanical energy when dissipative forces are negligible

The roller coaster car's total mechanical energy (Fig. 9.8), which is the sum of its kinetic and potential energies, remains constant at all points of the track (ignoring frictional forces). The combination of the kinetic and potential energies does vary, however. When the only work done on an object is performed by conservative forces, its mechanical energy remains constant, whatever motions it may undergo.

Say, for example, that you see a roller coaster at two different points on a track Point 1 and Point 2 so that the coaster is at two different heights and two different speeds at those points. Because mechanical energy is the sum of the potential energy = **mass** × **gravity** × **height** and kinetic energy  $\frac{1}{2} \times \text{mass} \times \text{velocity squared}$ , the total **mechanical energy** at Point 1 is

$$M.E_1 = mgh_1 + \frac{1}{2} mv_1^2$$

At Point 2, the total mechanical energy is  $M.E_2 = mgh_2 + \frac{1}{2} mv_2^2$

What's the difference between  $ME_2$  and  $ME_1$ ? If there's no friction (or another non-conservative force), then  $ME_1 = ME_2$ , or

$$mgh_1 + \frac{1}{2} mv_1^2 = mgh_2 + \frac{1}{2} mv_2^2$$

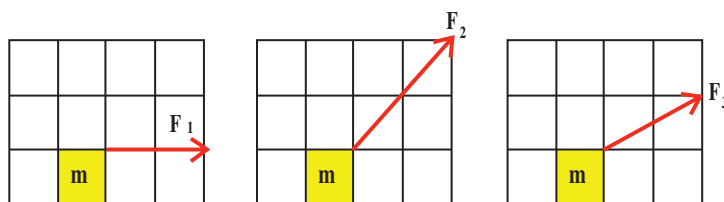
These equations represent the *principle of conservation of mechanical energy*. The principle says that if the net work done by non-conservative forces is zero, the total mechanical energy of an object is conserved; that is, it doesn't change. (If, on the other hand, friction or another non-conservative force is present, the difference between  $ME_2$  and  $ME_1$  is equal to ( $W_{nc}$ ) the net work of the non-conservative forces do:  $ME_2 - ME_1 = W_{nc}$ .) Another way of rattling off the principle of conservation of mechanical energy is that at Point 1 and Point 2,  $PE_1 + KE_1 = PE_2 + KE_2$

You can simplify that mouthful to the following:  $ME_1 = ME_2$

Where  $ME$  is the total mechanical energy at any one point. In other words, an object always has the same amount of energy as long as the net work done by non-conservative forces is zero.

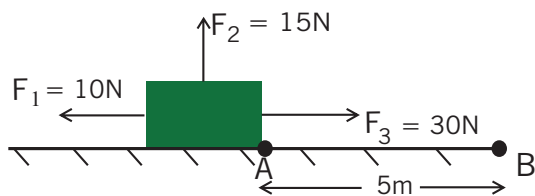
### 9.6 Unit 9 assessment

1. A 580kg rollercoaster is going 7.5m/s on the top of a 1.2m tall hill, how fast is it going on top of a 3.5m tall hill? (Neglect friction)
2. In the picture given below (Fig. 9.9), forces act on objects. Works done on objects during time  $t$  are  $W_1$ ,  $W_2$  and  $W_3$ . Find the relation of the works. Find the relation of the three works.



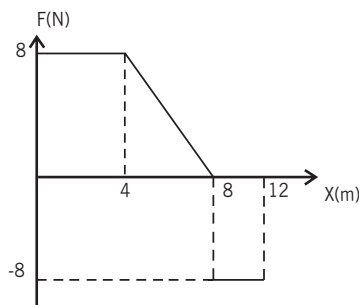
**Fig. 9.9:** Forces acting on objects in different directions

3. A box having 2kg mass, under the effect of forces  $F_1$ ,  $F_2$  and  $F_3$ , takes distance 5m. Which ones of the forces do work.



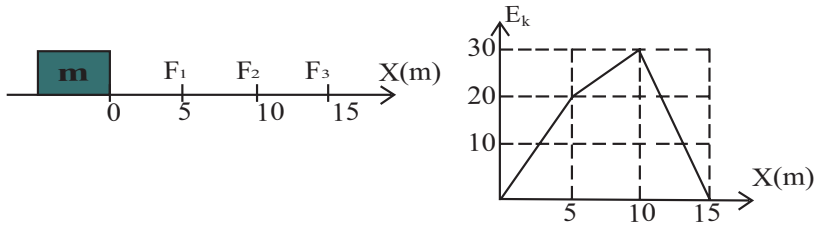
**Fig. 9.10:** A box acted on by three forces

4. Applied force vs. position graph of an object is given below. Find the kinetic energy gained by the object at a distance 12m.



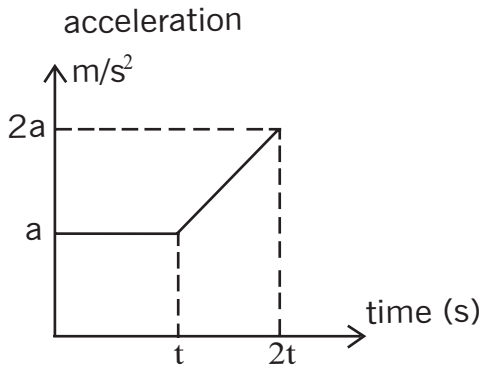
**Fig. 9.11:** Force-position graph

5. Three different forces are applied to a box in different intervals. Graph, given below, shows kinetic energy gained by the box in three intervals. Find the relation between applied forces.



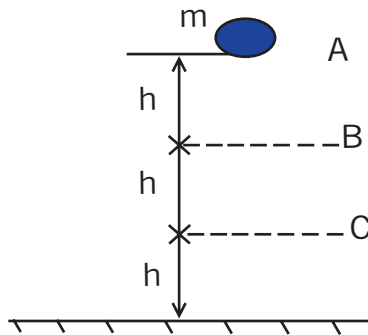
**Fig. 9.12:** Friction force versus distance moved

6. A stationary object at  $t = 0$ , has an acceleration vs. time graph given below. If an object has kinetic energy  $E$  at  $t = t$ , find the kinetic energy of the object at  $t = 2t$  in terms of  $E$ .



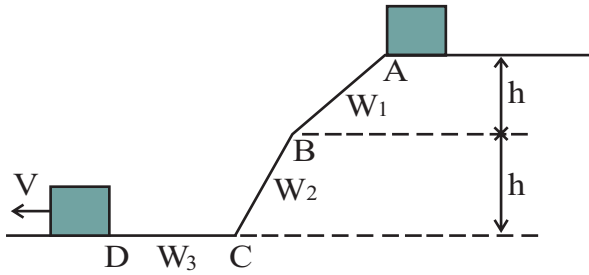
**Fig. 9.13:** Acceleration-time graph

7. An object does free fall. The picture given below shows this motion. Find the ratio of kinetic energy at point C to the total mechanical energy of the object.



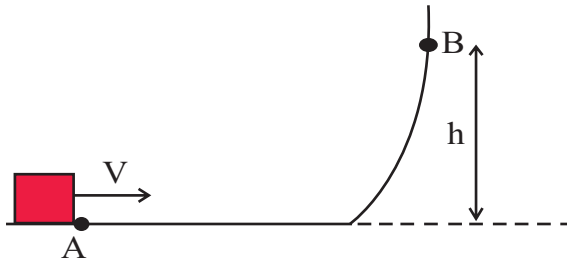
**Fig. 9.14:** Free fall diagram

8. A box is released from point A and it passes point D with a velocity,  $V$ . The work done by gravity is  $W_1$  between AB,  $W_2$  between BC and  $W_3$  between CD. Find the relation between them.



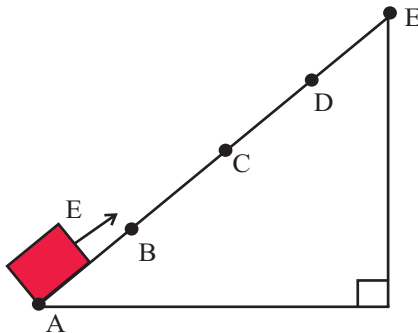
**Fig. 9.15:** Box moving under gravity

9. An object is projected with an initial velocity  $V$  from point A. It reaches point B and turns back to point A and stops. Find the relation between the kinetic energy object has at point A and energy lost on friction.



**Fig. 9.16:** Energy conservation of a thrown box

10. An object is projected from point A with an initial kinetic energy  $E$ , and it reaches point C. How much energy must be given to the object in order for it to reach point D.



**Fig. 9.18:** Object moving under gravity

---

# **Thermodynamics**

## Gas Laws

---







# Unit 10

## Gas Laws' Experiments

### Key unit competence

---

By the end of this unit I should be able to describe and analyse gas laws experiments.

### My goals

---

By the end of this unit, I will be able to:

- State and explain the behaviour and properties of an ideal gas.
- Discuss the equation of perfect gas. (Ideal gas).
- Define boyle's law, charles's law, pressure law, and dalton's law.
- Apply the gas law equations in problem solving.
- Carry out an experiment to verify dalton's law of partial pressure.
- Carry out an experiment to verify boyle's law, charles's law and pressure law.
- Explain equations of perfect gas. (Ideal gas)
- Discuss the gas laws.
- Explain how a change in volume of a fixed mass of gas at constant temperature is caused by a change in pressure applied to the gas.
- Understand; think logically and systematically when relating gas laws.
- Adopt scientific methods applied in solving gas problems.
- Adopt scientific methods in analysing, modeling and establishing the dimensions of gas laws.

## Key concepts

1. What do you understand by the concept of an ideal gas?
2. Describe the laws of gas and discuss their application in real life.
3. How do you mix gases?
4. What do you use to measure gas pressure?



## Vocabulary

Ideal gas or perfect gas, partial pressure, real gas, gas constant.



## Reading strategy

After you read each section, re-read the paragraphs that contain definitions of key terms. Use all the information you have learnt to explain each key term in your own words and draw your own experiment.

Master the procedures of each experiment so that you will be able to carry out similar experiments in the future.

## 10.1 Introduction



### Activity 10.1: The Balloon and the Bottle Experiment

#### Materials:

- Water
- Soda bottle (50ml)
- Balloon

#### Procedure:

Find an empty glass bottle (a soda bottle will work) and fill it with about 20 ml of boiling water. Stretch a balloon over the mouth of the bottle. As the bottle cools, the gas will suck the balloon into the bottle and it will begin to inflate within the bottle.

#### Questions:

1. Why is the balloon being sucked into the bottle as the water cools?
2. What would happen if you heat the water again when the balloon is still stretched over the bottle's mouth?

The study of heat and its transformation to mechanical energy is called thermodynamics (which stems from Greek words meaning movement of heat). Thermodynamics is the dynamics of heat.

**Statistical systems are systems with large numbers of particles** (atoms and / or molecules). By large, we mean on the order of  $6.022 \times 10^{23}$  ("Avogadro's Number", designated  $N_A$ ; one mol).

The measurable quantities are called "state variables". As their name implies, **their values depend only on the current state of the system, and not on the path taken to that state:** they have no memory of their past values. Three of the most important state variables are temperature, pressure and volume. Temperature and pressure are "intrinsic" state variables, since their value does not depend on the "size" of the system. Volume is an "extrinsic" state variable, since its value does depend on the size of the system.

In thermodynamics, all temperatures are measured in "Kelvin" ( $K = \text{Celsius} + 273.15$ ). Zero K is called "absolute zero", since it is the lowest possible temperature. A temperature difference of 1K is equal to a temperature difference of 1 °C. We will not be concerned with pressure all that much, since most physiological functions assume a constant pressure equivalent to that of the atmosphere. We will typically measure volume in liters.

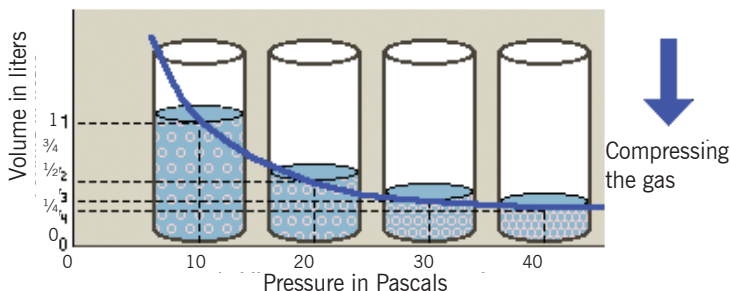
Let us find the volume of one mol of air using its density and gram molecular weight (the mass of one mol of a substance in grams is numerically equal to its molecular weight). If air is 78.08%  $N_2$  (with molecular weight 28), 20.95%  $O_2$  (32) and 0.93% Ar (40), and the remaining 0.04% is represented by other gases, the average molecular weight of air is 28.94g/mol. Since the density of air at standard temperature and pressure is  $1.293\text{kg/m}^3$ , one mole of air then occupies 22.4l ( $0.224\text{m}^3$ ).

## 10.2 Three gas laws

The early gas laws were developed at the end of the eighteenth century, when scientists began to realise that relationships between the pressure, volume and temperature of a sample of gas could be obtained which would hold for all gases. Gases behave in a similar way over a wide variety of conditions because to a good approximation they all have molecules which are widely spaced, and nowadays the equation of state for an ideal gas is derived from kinetic theory. The earlier gas laws are now considered as special cases of the ideal gas equation, with one or more of the variables held constant.

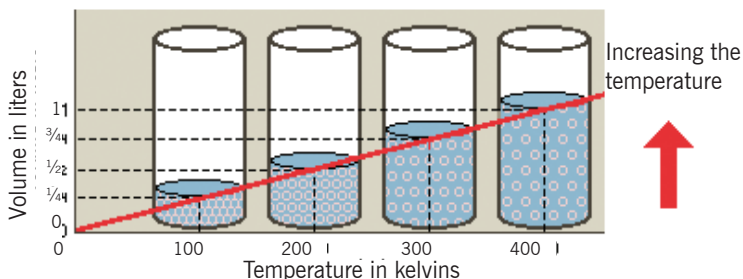
**Boyle's Law**

If a fixed mass of a gas is held at a **constant temperature**, the volume is inversely proportional to the pressure. Compressing a gas to half of its original volume doubles its pressure.



**Charles' Law**

If a fixed mass of a gas is held at a **constant pressure**, the volume is directly proportional to the absolute temperature. Heating a gas to double its original temperature doubles its volume.



**Fig. 10.1:** Boyle's law and Charles' law

10.2.1 Boyle's law



**Activity 10.2: Investigating Boyle's law**

**Materials:**

- A 50 ml syringe
- A small sized balloon



**Fig. 10.2:** A Syringe

**Procedure:**

- First, trap a small amount of air in the balloon and tie a knot.
- Place the balloon in the syringe.
- With your finger, close the syringes' nose and press the piston as in Fig. 10.2.

**Questions:**

1. Why is the balloon decreasing the size as the pressure increases?
2. Why is its volume increasing as the pressure decreases?
3. Discuss and explain where this can be observed in real life.

Robert Boyle (1627-1691), the English natural philosopher and one of the founders of modern chemistry; is best remembered for Boyle's law (1662), a physical law that explains how the pressure and volume of a gas are related. It states that;

**“The volume of a fixed mass of gas is inversely proportional to the pressure, provided the temperature remains constant”.**

$$V \propto \frac{1}{p} \text{ or } P \propto \frac{1}{v}$$

$PV = C^t$  where  $C^t$  is a constant.

We can re-write this equation as:  $P_1 V_1 = P_2 V_2$

This relationship means that pressure increases as volume decreases, and vice versa.

### Examples:

1. A sample of gas has an initial pressure of 2.44 atm and an initial volume of 4.01 L. Its pressure changes to 1.93 atm. What is the new volume if temperature and amount are kept constant?

$$P_1 = 2.44 \text{ atm}$$

$$V_1 = 4.01 \text{ L}$$

$$P_2 = 1.93 \text{ atm}$$

$$V_2 = ?$$

Using  $P_1 V_1 = P_2 V_2$

$$V_2 = 2.44 \times 4.01 / 1.93 = 5.07 \text{ L}$$

2. A sample of gas has an initial pressure of 722 torr and an initial volume of 88.8 mL. Its volume changes to 0.663 L. What is the new pressure?

$$P_1 = 722 \text{ torr}$$

$$V_1 = 88.8 \text{ mL}$$

$$P_2 = ?$$

$$V_2 = 0.663 \text{ L} = 663 \text{ mL}$$

Using  $P_1 V_1 = P_2 V_2$

$$P_2 = \frac{722 \times 88.8}{663} = 96.7 \text{ torr}$$

### 10.2.2 Charles' law



## Activity 10.3: Demonstrating Charles's Law by Expanding and Contracting a Balloon

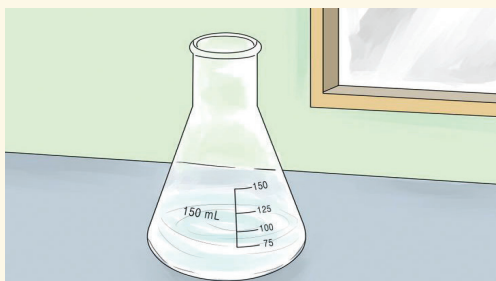
#### Materials:

- Erlenmeyer flask or retort flask
- Water
- Electric heater ( Hot plate)
- Balloon

#### Procedure:

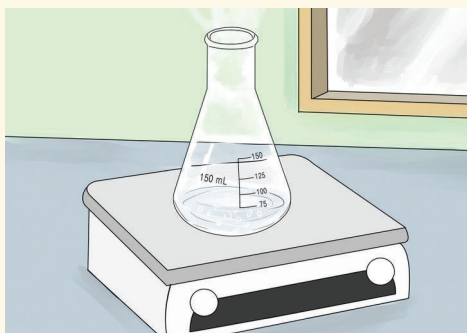
Carry out the steps from A to F shown below and answer the questions:

- a) Add a small amount of water to an Erlenmeyer flask as shown in Fig.10.3.



**Fig. 10.3:** Erlenmeyer (retort flask)

- b) Place the flask on a hot plate or burner as shown in Fig 10.4.



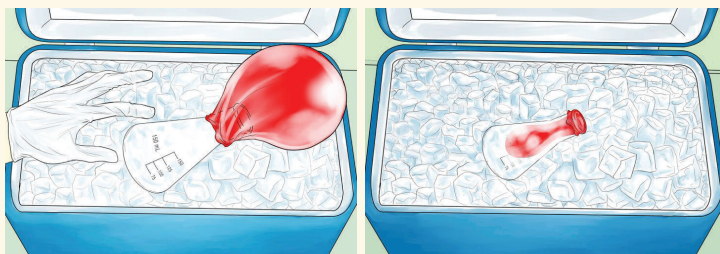
**Fig. 10.4:** Flask on a hot plate

- c) Put the open end of a balloon over the opening of the flask as shown in Fig. 10.5.



**Fig. 10.5:** The balloon knotted on the flask's opening

- d) Observe the expansion of the balloon and record your observations.  
e) Move the flask to an ice bath as in Fig 10.6.



**Fig. 10.6:** The flask in the ice bath

- f) What happens to the balloon?

### Questions:

1. What is causing the balloon to expand in step c?
2. What is causing the balloon to contract in step e?
3. Discuss and explain this effect in your own words?

**Charles' law** or law of volumes (French chemist Jacques Charles 1787), relating volume and temperature at constant pressure states that:

*'The volume of a given amount of gas is directly proportional to absolute temperature when pressure is kept constant'.*

$$V \propto T$$

$$V = TC_p \text{ where } C_p \text{ is a constant or } \frac{V_1}{T_1} = \frac{V_2}{T_2}$$

The process where the temperature and volume change at constant pressure is called **Isobaric process**.

**Example:**

A 600 mL sample of nitrogen is heated from 27 °C to 77 °C at constant pressure. What is the final volume?

$$\begin{aligned} T_1 &= 27 + 273 = 300K \\ T_2 &= 77 + 273 = 350K \\ V_1 &= 600mL \\ V_2 &=? \\ V_2 &= \frac{V_1 T_2}{T_1} = \frac{600 \times 350}{300} = 700 \text{ mL} \end{aligned}$$

**More Examples of Charles' Law**

If you think Charles' Law seems irrelevant to real-life situations, think again! By understanding the basics of the law, you'll know what to expect in a variety of real-world situations and once you know how to solve a problem using Charles' Law, you can make predictions and even start to plan new inventions. Here are several examples of situations in which Charles' Law is at play:

- If you take a basketball outside on a cold day, the ball shrinks a bit as the temperature is decreased. This is also the case with any inflated object and explains why it's a good idea to check your car's tire pressure when the temperature drops.
- If you over-inflate a pool float on a hot day, it can swell in the sun and burst.

**10.2.3 Gay-Lussac's law**



**Activity 10.4: How to Crush a Can with Air Pressure**

You can crush a soda can using nothing more than a heat source and a bowl of water. This is a great visual demonstration of some simple scientific principles, including air pressure (Pressure law) and the concept of a vacuum. The experiment can be performed by teachers as a demonstration, or by mature learners under supervision.

Using the following steps a) to e), do the experiment and notice the changes and observations.

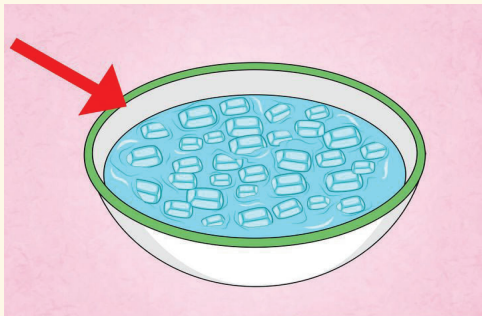


- a) Pour a little water into an empty soda can as in Fig. 10.7.



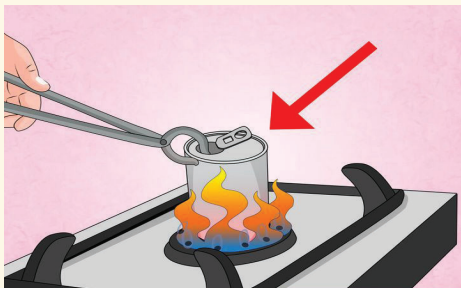
**Fig. 10.7:** Soda can

- b) Prepare a bowl of ice water as in Fig.10.8.



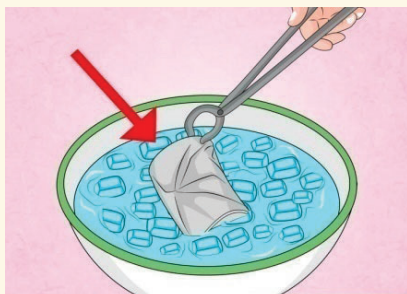
**Fig. 10.8:** Bowl of ice water

- c) Heat the can on the stove as in Fig.10.9.



**Fig. 10.9:** Heating the soda can

- d) Use the tongs to turn the hot can upside down into the cold water.



**Fig. 10.10:** The hot can in the cold water

- e) What happens when you heat the can of water?

**Questions:**

1. What happens inside the can when being heated?
2. Why when inverted in cold water does the can collapse?
3. Discuss and explain the phenomena of crushing can.

**Pressure law** or Third gas law (French chemist Joseph Guy-Lussac in 1809), relating temperature and pressure at constant volume states that:

*“For a fixed mass of a gas, the pressure of the gas is directly proportional to the absolute temperature if its volume is kept constant”*

$P \propto T$  (at constant volume)

$$P = TC^v \text{ where } C^v \text{ is a constant or } \frac{P_1}{T_1} = \frac{P_2}{T_2}$$

The process where the pressure and temperature change at constant volume is called **Isochoric process**.

**Example:**

1. An ideal gas at temperature of 27°C and pressure 12kPa is cooled to half the original temperature. Calculate the new pressure.

**Solution:**

$$\begin{aligned} T_1 &= 27 + 273 = 300K \\ T_2 &= \text{half of } T_1 = 150K \\ P_1 &= 120kPa = 120,000Pa \\ P_2 &=? \\ P_2 &= \frac{P_1 \times T_2}{T_1} = \frac{12000 \times 150}{300} = 6000Pa \end{aligned}$$

2. In the sealed cylinder, the pressure of gas is recorded as  $1.0 \times 10^5 \text{ N/m}^2$  at a temperature of  $0^\circ\text{C}$ . The cylinder is heated further till the thermometer records  $150^\circ\text{C}$ . What is the pressure of the gas?

**Solution:**

$$P_1 = 1.0 \times 10^5 \text{ Nm}^{-2}$$

$$T_1 = 0^\circ\text{C} = 0 + 273 = 273 \text{ K} \quad (\text{remember to convert from Celsius to Kelvin})$$

$$T_2 = 150^\circ\text{C} = 150 + 273 = 423 \text{ K}$$

$$P_2 = ?$$

$$P_2 = \frac{P_1 \times T_2}{T_1} = \frac{1.0 \times 10^5 \times 423}{273} = 1.55 \times 10^5 \text{ Nm}^{-2}$$

### Checking my progress

- Why do gases exert pressure?
  - Because molecules have masses and weight.
  - Molecules bounce off the walls of the containing vessel and their rate of change of momentum on a certain area causes a pressure.
  - Molecules accelerate towards the walls of the containing vessel and their rate of change of density on a certain area causes a pressure.
  - The molecules of a gas are in a state of incessant, random motion inside the container.
- What is/are the relationship(s) between kinetic energy of gas molecules and the temperature of the gas?
  - If the temperature is increased, the molecules start moving more randomly and reduce kinetic energy.
  - The kinetic energy of the molecules is the energy possessed by virtue of motion of the particles, so they are directly proportional.
  - When the temperature is increased, the molecules start moving more randomly and gain kinetic energy.
  - The kinetic energy of the molecules is the energy possessed by virtue of position of the particles, so they are directly proportional.

3. Which law is also called Gay-Lussac's law?
- (a) Charles's law
  - (b) Pressure law
  - (c) Gas laws
  - (d) Boyle's law
4. A gas has pressure  $P$  and volume  $V$ , what is its final volume when the pressure is tripled?
- (a)  $V_f = \frac{V}{9}$
  - (b)  $V_f = \frac{V}{27}$
  - (c)  $V_f = \frac{V}{3}$
  - (d)  $V_f = 3V$
5. Molecules of a gas experience a larger change of ..... when they bounce off the walls of the container which contains the gas.
- (a) Density
  - (b) Humidity
  - (c) Force
  - (d) Momentum

## 10.3 Ideal gas

### 10.3.1 Definition

We can define an **ideal gas** as one which obeys Boyle's law exactly and whose internal energy is independent of its volume.

At normal ambient conditions such as standard temperature and pressure, most real gases behave qualitatively like an ideal gas. Generally, deviation from an ideal gas tends to decrease with higher temperature and lower density, as the work performed by intermolecular forces becomes less significant compared to the particles' kinetic energy, and the size of the molecules becomes less significant compared to the empty space between them.

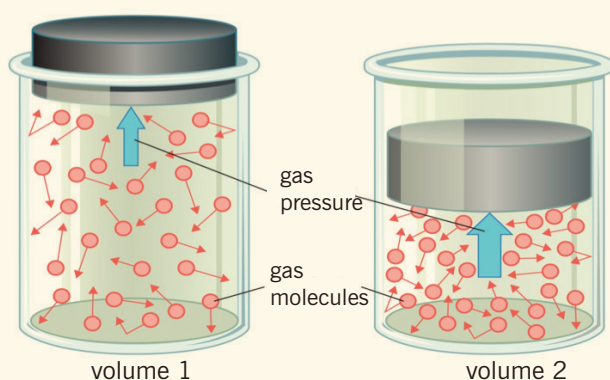
The ideal gas model tends to fail at lower temperatures or higher pressures, when intermolecular forces and molecular size become important. At some point of low temperature and high pressure, real gases undergo a phase transition, such as to a liquid or a solid.

### 10.3.2 Ideal gas law



#### Activity 10.5: Investigating ideal gas

Study carefully the Fig. 10.11 and answer to the following questions:



**Fig. 10.11:** Ideal gas containers

#### Questions:

1. What is the difference between molecules of gas contained in the volume 1 and volume 2?
2. Where is gas pressure greater between the two containers?
3. Comment on the relationship between the volume change and pressure change in each case.

The combined gas law or general gas equation is formed by the combination of the three laws, and shows the relationship between the pressure, volume and temperature for a fixed mass of gas:

$$\frac{P_1 \times V_1}{T_1} = \frac{P_2 \times V_2}{T_2}$$

We can write this as an equation:  $PV = nRT$ ; where;

- P is the absolute pressure (Unit used: atmospheres, atm or Pascal).
- V is the volume (Unit used: litre,  $l$  or  $m^3$ ).
- n is the amount of substance (loosely number of moles of gas).

- R is the gas constant of proportionality, it is called the Universal gas constant because its value is found experimentally to be the same for all gasses. Its value is  $R = 8.31447J/(mol.K)$  or  $R = 0.0821L \cdot atm \cdot mol^{-1} K^{-1}$
- T is the temperature on the absolute temperature scale (Unit used: Kelvin).

### Examples:

1. An automobile tire is filled to a gauge pressure such that now the total pressure inside is 301kPa at 10 °C. After a drive of 100km, the temperature within the tire rises to 40 °C. If the volume does not change, what is the pressure within the tire now?

### Solution:

$$P_1 = 301kPa = 301000 Pa$$

$$P_2 = ?$$

$$T_1 = 10 + 273 = 283 K$$

$$T_2 = 40 + 273 = 313 K$$

$$V_1 = V_2$$

So, the formula deduces to;

$$P_2 = \frac{P_1 \times T_2}{T_1} = \frac{301 \times 10^3 \times 313}{283} = 333kPa$$

2. A compressed air tank holds 0.500m<sup>3</sup> of air at a temperature of 285 K and a pressure of 880 kPa. What volume would the air occupy if it were released into the atmosphere, where the pressure is 101 kPa and the temperature is 303 K?

### Solution:

$$V_2 = \frac{P_1 T_2}{P_2 T_1} V_1 = \frac{(880kPa)(303)(0.5)}{(101kPa)(285)}$$

$$= 4.63m^3$$

These equations are exact only for an ideal gas, which neglects various intermolecular effects. However, the ideal gas law is a good approximation for most gases under moderate pressure and temperature.

This law has the following important consequences:

1. If temperature and pressure are kept constant, then the volume of the gas is directly proportional to the number of molecules of gas.
2. If the temperature and volume remain constant, then the pressure of the gas changes is directly proportional to the number of molecules of gas present.
3. If the number of gas molecules and the temperature remain constant, then the pressure is inversely proportional to the volume.
4. If the temperature changes and the number of gas molecules are kept constant, then either pressure or volume (or both) will change in direct proportion to the temperature.

### 10.3.3 Dalton's law of partial pressure

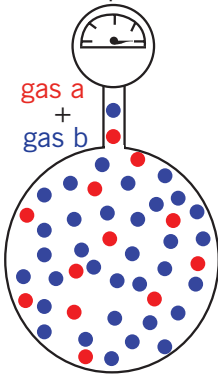


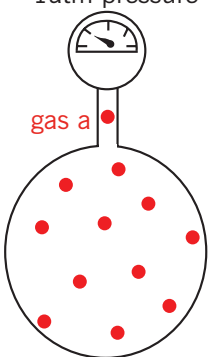
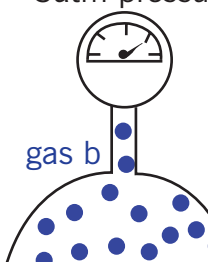
#### Activity 10.6: Partial pressure experiment

Use the information in table 10.1, to discuss and explain the effect of partial pressure of two or more gases.

### Partial Pressure

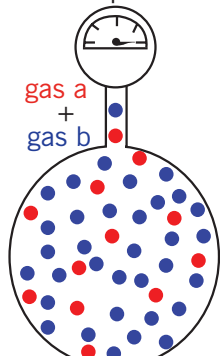
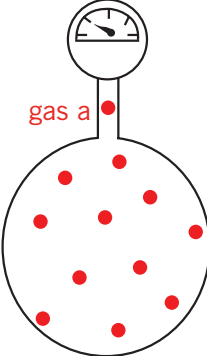
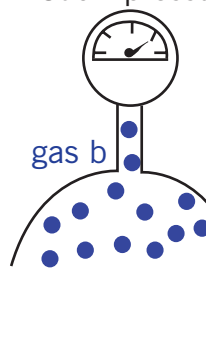
Table 10.1: Dalton's Law of Partial Pressures

Description of partial pressure	Illustration
<p>A container of fixed volume at constant temperature holds a mixture of <b>gas a</b> and <b>gas b</b> at a total pressure of 4atm.</p> <p>The total pressure in the container is proportional to the number of gas particles.</p> <p>More gas particles = greater pressure. Less gas particles = lower pressure.</p> <p>If each dot represents 1 mole of gas particles, then there are 48 moles of gas particles in this container exerting a total pressure of 4atm.</p>	<p>4atm pressure</p> 

<p>Imagine the container with no particles of <b>gas b</b>.                  Only particles of <b>gas a</b> are present in the same container at the same temperature.                  Now the container holds only 12 moles of gas particles instead of the 48 moles of gas particles it originally contained.                  Since pressure is proportional to the number of gas particles, the pressure exerted by <b>gas a</b> = <math>12\text{mol} \div 48\text{mol} \times 4\text{atm} = 1\text{atm}</math></p>	<p>1atm pressure</p> 
<p>Imagine the container with no particles of <b>gas a</b>.                  Only particles of <b>gas b</b> are present in the same container at the same temperature.                  Now the container holds only 36 moles of gas particles instead of the 48 moles of gas particles it originally contained. Since pressure is proportional to the number of gas particles, the pressure exerted by <b>gas b</b> = <math>36\text{mol} \div 48\text{mol} \times 4\text{atm} = 3\text{atm}</math></p>	<p>3atm pressure</p> 

The total pressure in a gas mixture is the sum of the partial pressures of each individual gas.

**Table 10.2:** Dalton's law of partial pressure

P <sub>total</sub>	=	P <sub>gas a</sub>	+	P <sub>gas b</sub>
<p>4atm pressure</p> 	=	<p>1atm pressure</p> 	+	<p>3atm pressure</p> 

**Examples**

1. 10 g of nitrogen gas and 10 g of helium gas are placed together in a 10 l container at 25°C. Calculate the partial pressure of each gas and the total pressure of the gas mixture.



**Solution**

Calculate the moles ( $n$ ) of each gas present:  $n = \text{mass} \div \text{molar mass}$

**Table 10.3: Molar mass**

	nitrogen ( $\text{N}_2(\text{g})$ )	helium ( $\text{He}(\text{g})$ )
mass (g)	10 g	10 g
molar mass (g mol <sup>-1</sup> )	$2 \times 14 = 28$	4
$n = \text{mass} \div \text{molar mass}$	$10 \div 28 = 0.4 \text{ mol}$	$10 \div 4 = 2.5 \text{ mol}$

Calculate the total moles of gas present =  $0.4 + 2.5 = 2.9 \text{ mol}$

Calculate the total gas pressure assuming ideal gas behaviour:

$$PV = nRT$$

$$P = n \times R \times T \div V$$

$$n = 2.9 \text{ mol}$$

$$R = 8.314$$

$$T = 25^\circ\text{C} = 25 + 273 = 298\text{K}$$

$$V = 10\text{l}$$

$$P = 2.9 \times 8.314 \times 298 \div 10 = 718\text{kPa} (7 \text{ atm})$$

Partial pressure of nitrogen =  $n(\text{N}_2) \div n(\text{total}) \times \text{total pressure}$

Partial pressure of nitrogen =  $0.4 \div 2.9 \times 718\text{kPa} = 99\text{kPa} (0.9 \text{ atm})$

Partial pressure of helium =  $n(\text{He}) \div n(\text{total}) \times \text{total pressure}$

Partial pressure of helium =  $2.5 \div 2.9 \times 718 = 619\text{kPa} (6.1\text{atm})$

2. At  $15^\circ\text{C}$ , 25mL of neon at 101.3 kPa (1 atm) pressure and 75 mL of helium at 70.9kPa (0.7 atm) pressure are both expanded into a 1l sealed flask. Calculate the partial pressure of each gas and the total pressure of the gas mixture.

**Solution**

Since the temperature and moles of each gas is constant, the pressure exerted by each gas is inversely proportional to its volume (Boyle's Law).

$$P_i V_i = P_f V_f$$

$$P_f = P_i V_i \div V_f$$

Partial pressure Neon =  $101.3\text{kPa} \times 25 \times 10^{-3}\text{L} \div 1\text{l} = 2.5 \text{ kPa}$

Partial pressure Helium =  $70.9\text{kPa} \times 75 \times 10^{-3}\text{L} \div 1\text{l} = 5.3 \text{ kPa}$

Total pressure =  $2.5 + 5.3 = 7.8\text{kPa}$

**Dalton's law** of Partial Pressures states that 'The pressure of a mixture of gases simply is the sum of the partial pressures of the individual components'. Dalton's Law is as follows:

$$PV = P_1V_1 + P_2V_2 + \dots + P_nV_n \text{ where } V = V_1 + V_2 + \dots + V_n$$

The partial pressures of the individual components:

$$P_i = P \frac{V}{V_i} \text{ at the same temperature}$$

### 10.3.4 Density of gases

Density has the units of mass per unit volume

From ideal gas equation we have:  $PV = nRT \Leftrightarrow \frac{n}{V} = \frac{P}{RT}$

( $n/V$ ) has the units of **moles/litre**.

If we know the molecular mass of the gas, we can convert this into **grams/litre** (mass/volume).

The **molar mass (M)** is the number of grams in one mole of a substance. If we multiply both sides of the above equation by the molar mass:

$$\frac{nM}{V} = \frac{PM}{RT}$$

The left hand side is now the number of grams per unit volume, or the mass per unit volume (which is the *density*)

Thus, the density (**d**) of a gas can be determined according to the following:

$$d = \frac{PM}{RT}$$

Alternatively, if the density of the gas is known, the molar mass of a gas can be determined:

$$M = \frac{dRT}{P}$$

**Example:** What is the density of carbon tetrachloride vapour at 714 torr and 125°C?

**Answer:**

The molar mass of  $\text{CCl}_4$  is  $12.0 + (4 \times 35.5) = 154\text{g/mol}$ .

125°C in degrees Kelvin would be  $(273+125) = 398\text{K}$ .

Since we are dealing with torr, the value of the gas constant, R, would be 62.36l torr/mol K.

$$d = \frac{PM}{RT} = \frac{(714 \text{ torr})(154 \text{ g/mol})}{(6236 \text{ Ltorr/molK})(298\text{K})} = 4.43\text{g/L}$$

**Note:** The standard atmosphere (atm) of pressure is approximately equal to air pressure at earth mean sea level and is defined as:  $1 \text{ atm} = 101325 \text{ Pa} = 1013.25 \text{ mbar} = 760 \text{ Torr}$

### 10.3.5 Avogadro's Law

- This law states that at a fixed temperature and pressure, the volume of gas is directly proportional to the number of moles (or molecules),  $n$ .

This can be expressed as;  $V \propto n$  Or  $\frac{V}{n} = \text{constant}$

As with other laws, we can have this as  $\frac{V_1}{n_1} = \frac{V_2}{n_2}$

- Avogadro's law implies that at the same conditions of temperature and pressure, equal volumes of all gasses contain equal numbers of molecules.

#### **Example:**

For example, the molecular weight of oxygen is 32.00, so that one gram-mole of oxygen has a mass of 32.00 grams and contains  $6.02214 \times 10^{23}$  molecules.

**Avogadro's number** is defined as the number of elementary particles (molecules, atoms, compounds, etc.) per mole of a substance. It is an absolute number written as  $6.02214 \times 10^{23} \text{ mol}^{-1}$

## 10.4 Unit 10 assessment

1. One atmosphere is equal to (Choose the correct answer):
  - a) 760 cm Hg
  - b) 760 mm Hg
  - c) 101325 mm Hg
  - d) 8.314 mm Hg
2. Which of the following quantities is not necessary to describe a gas? (Choose the correct answer)
  - a) Volume
  - b) Temperature
  - c) Amount
  - d) Pressure
3. Dalton's Law of Partial Pressures states that (Choose the correct answer):
  - a) The total pressure exerted by a mixture of gases can be determined using the Ideal Gas Constant.
  - b) The pressure of a gas is inversely proportional to both the temperature and number of moles of the gas.
  - c) The total pressure exerted by a mixture of gases is equal to the sum of the pressures exerted by the individual components in the mixture.
  - d) You must take into consideration the vapour pressure of the solvent that you are using.
4. Convert centigrade temperature to Kelvin (Choose the correct answer):
  - a)  $^{\circ}\text{C} - 273.15$
  - b)  $^{\circ}\text{C} + 273.15$
  - c)  $^{\circ}\text{F} - 273.15$
  - d)  $^{\circ}\text{F} + 273.15$
5.  $125\text{cm}^3$  of gas are collected at  $15^{\circ}\text{C}$  and 755 mm of mercury pressure. Calculate the volume of the gas at s.t.p
6. When tested in a cool garage at  $12^{\circ}\text{C}$  a motor tyre is found to have a pressure of 190kPa. Assuming the volume of the air inside remains constant, what would you expect the pressure to become after the tyre has been allowed to stand in the sun so that the temperature rises to  $32^{\circ}\text{C}$ ? Atmospheric pressure = 100kPa.
7. Pure helium gas is contained in a leakproof cylinder containing a movable piston. The initial volume, pressure, and temperature of

- the gas are 15l, 2.0 atm, and 310K, respectively. If the volume is decreased to 12l and the pressure is increased to 3.5atm, find the final temperature of the gas.
8. Determine the volume of 1 mol of any gas at STP, assuming it behaves like an ideal gas.
  9. A gas occupies a volume of 25.8l at 17°C and under 690mm Hg. What volume will it occupy at 345K and under 1.85atm?
  10. Oxygen is collected in a bottle, turned upside down, containing water at 27°C. The barometer pressure measured in the bottle is 757 torr. Calculate the partial pressure of O<sub>2</sub> knowing that the vapour pressure of water is 19.8 mm Hg at 27°C.
  11. We mix 200ml of N<sub>2</sub> at 25°C and under 250 torr with 350 ml of O<sub>2</sub> at 25°C and under 300 torr, the final pressure is 300 torr and the final volume is 300ml. What will be the final pressure at 25°C?

---

**Electricity**

Magnetism (II)

---



# Unit 11

## Magnetization and Demagnetization

### Key unit competence

---

By the end of this unit I should be able to describe methods of magnetization and demagnetization

### My goals

---

By the end of this unit, I will be able to:

- Review previous knowledge of magnets.
- Describe the magnetic properties of iron and steel.
- Describe the methods of magnetizing and demagnetizing of materials.
- Explain use of keepers in storing magnets.
- Explain magnetic shielding.

### Key concepts

---

1. What is needed to describe magnetism of body?
2. How to magnetize or demagnetize a body?
3. When a body is magnetized or demagnetized?



### Vocabulary

---

Magnetization, demagnetization, hammering, stroking, heating.



## Reading strategy

After you read each section of this unity 11, reread the paragraphs that contain definitions of key terms. Use all the information you have learned to write a definition of each key term in your own words to performing your own experimental works about magnetization.

### 11.1 Structure of an atom and magnetism



#### Activity 11.1: Investigating magnetism through materials

Take the following materials and follow instruction provided and answer to questions.

##### Materials:

- Permanent magnet
- Iron piece of metal
- Aluminum or brass piece of metal

##### Procedures:

- Take the magnet and approach it to an iron piece of metal and notes your observation
- Take the magnet and approach it to an aluminum piece of metal and notes your observation

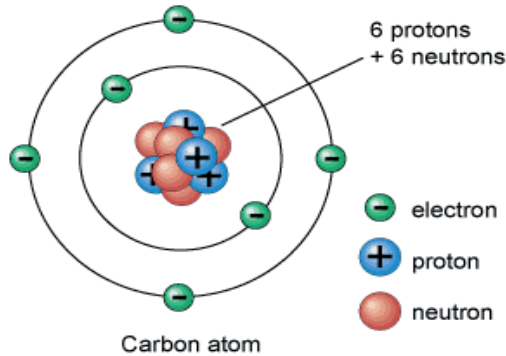
##### Question:

1. Are all pieces of metals being attracted by a magnet? Discuss your observation
2. What are the differences between the two metals
3. Is there any difference due to their electronic configuration?
4. Discuss other materials that can be attracted by a magnet and other which cannot be attracted by a magnet.

#### 11.1.1 STRUCTURE OF AN ATOM

An atom is the smallest constituent unit of ordinary matter that constitutes a chemical element. Every solid, liquid, gas, and plasma is composed of neutral or ionized atoms.





**Fig.11. 1 Atomic structure of Carbon atom**

**Electron (e<sup>-</sup>)** - Electron is denoted by 'e' and is a negatively charged particle. The absolute charge over an electron is equal to  $-1.6 \times 10^{-19}$  Coulomb which is negative charge.

The relative mass of electron is  $1/1836$  of the mass of a Proton. Since the mass of an electron is very small, thus it is considered equal to 0. Electrons revolve round the nucleus of atoms.

$$\text{Mass of electron } m_e = 9.1 \times 10^{-31} \text{ kg}$$

**Proton (p<sup>+</sup>)** - Proton is denoted by 'p' and is positively charged particle. The absolute charge over proton is  $1.6 \times 10^{-19}$  coulomb of positive charge and it is considered as unit positive charge. Thus absolute charge over a proton is equal to +1.

The absolute mass of a proton is equal to  $1.6 \times 10^{-27}$  kg and considered equal to 1 as it is equal to the mass of 1 hydrogen atom. Proton is present in the nucleus of atom.

$$\text{Mass of proton } m_p = 1.67 \times 10^{-27} \text{ kg}$$

**Neutron (n)** – Neutron is denoted by 'n' and is a neutral particle.

The absolute mass of neutron is  $1.6 \times 10^{-27}$  kg. The relative mass of neutron is equal to 1. Neutron is presents in the nucleus of atom.

$$\text{Mass of neutron } m_n = 1.67 \times 10^{-27} \text{ kg}$$

**Nucleus** – The centre of atom is called nucleus. Nucleus comprises of neutron and proton. Nucleus of an atom contains the whole mass of an atom.

**Discovery of Electron:**

In 1897; J. J. Thomson, a British physicist, proposed that atom contains at least one negatively charged particle. Later this particle was named as electron. Thomson called those particles 'corpuscles'.

**Discovery of Proton:**

Ernest Goldstein in 1886 discovered the presence of new radiation in gas discharge tube even before the identification of electron. He called these rays as Canal Rays. His experiment led to the discovery of proton.

**11.1.2 MAGNETISM**

The magnetic properties of a given element depend on the electron configuration of that element, which will change when the element loses or gains an electron to form an ion. If the ionization of an element yields an ion with unpaired electrons, these electrons may align the sign of their spins in the presence of a magnetic field, making the material paramagnetic. If the spins tend to align spontaneously in the absence of a magnetic field, the resulting species is termed ferromagnetic.

**Magnetism** is a class of physical phenomenon that includes forces exerted by magnets on other magnets. It has its origin in electric currents and the fundamental magnetic moments of elementary particles. These give rise to a magnetic field that acts on other currents and moments. Magnetism, phenomenon associated with the motion of electric charges. This motion can take many forms. It can be an electric current in a conductor or charged particles moving through space, or it can be the motion of an electron in atomic orbit. Magnetism is also associated with elementary particles, such as the electron, that have a property called spin.

**Checking my progress**

1. How do you determine the magnetism of an element?
2. Why do unpaired electrons cause magnetism?
3. What is difference between paramagnetic and diamagnetic?

## 11.2 MAGNETIC DOMAIN



### Activity 11.2: Investigating the magnetic domain using iron filings

#### Materials:

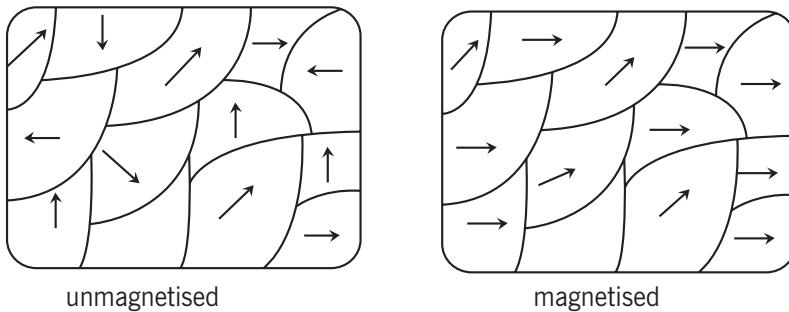
- Magnet
- Iron filings
- A plain paper

#### Procedure:

- Take the iron filings on the paper, under the paper, hold a magnet and try to move it slightly.

#### Question:

Discuss and explain the changes you are observing.



**Fig. 11.2:** Magnetic domain

A magnetic domain is region in which the magnetic fields of atoms are grouped together and aligned. In the fig.11.2, the magnetic domains are indicated by the arrows in the metal material. You can think of magnetic domains as miniature magnets within a material. In an unmagnetized object, all the magnetic domains are pointing in different directions. But, when the metal became magnetized, which is what happens when it is rubbed with a strong magnet, all like magnetic poles lined up and pointed in the same direction. The metal became a magnet. It would quickly become unmagnetized when its magnetic domains returned to a random order.

Magnetic domains are always present in ferromagnetic materials due to the way the atoms bond to form the material. However, when a ferromagnetic material is in the unmagnetized condition, the magnetic domains are randomly oriented so that the magnetic field strength in the piece of material is zero

In all ferromagnetic materials, microscopic bits of metal, called domains; have tiny magnetic fields. If their magnetic north and south poles line up, they cooperate and form a large field around the whole object. Impacts and heat scramble the orientation of the domains, weakening the field. Long periods of time also weaken magnets. During storage, a keeper reinforces the magnetic field, maintaining its strength for longer periods of time.

## 11.3 Magnetisation and demagnetisation

### 11.3.1 MAGNETISATION

- **MAGNETISATION BY CONTACT**



#### **Activity 11.3: Investigating magnetization of a ferromagnetic metal**

##### Materials:

- A permanent magnet
- A three iron nails

##### Procedure:

- Take a nail to another nail and check whether it can attract it. Discuss your observation.
- Take the strong magnet, approach it to one end of an iron nail.
- Let the other end of the nail on magnet attract another nail. And then let the second nail attract the third nail.

##### Questions:

- Could a nail only attract another nail?
- If not, why when a nail is attracted by a magnet, it can attract other nail too?
- Discuss if there were more nail, what would happen adding nails.

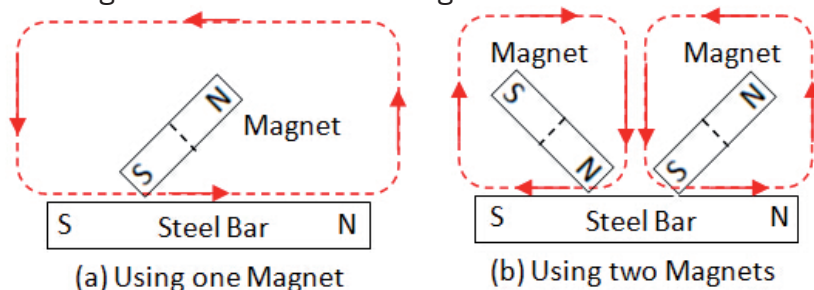
The process of converting iron or its alloys into a magnet is called **Magnetization**.

Re-magnetizing a magnet is often necessary if the magnet has been mistreated. Occasionally magnets are required to be made from pins etc. in order to make compasses. Also there are often requests to make a tool (e.g. screwdriver) magnetic so that it complies with a desired

function (e.g. difficult to retrieve screws are not lost). Sometimes a tool may have inadvertently become magnetic with unwanted consequences. There are a few methods of effecting the magnetization of an object. However, it is important to make sure that the object is of the “right stuff”. Magnetically “soft” iron when they are in contact with other permanent and strong magnets, they will magnetize but will lose the magnetism very quickly. This makes it ideal for electromagnets. Some stainless steels have very poor retention of field so should not be used.

### • MAGNETIZATION BY STROKING

This is, historically, the oldest form of consistently creating magnet. This produces magnets that are not as strong as the electrical methods. There are two methods which have traditionally been given the names “single touch” and “divided touch



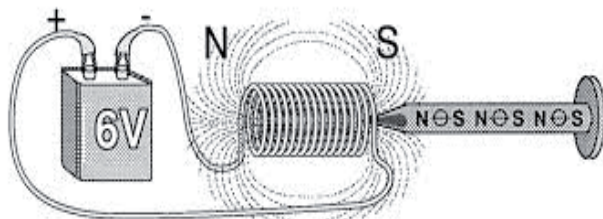
**Fig. 11. 3 Single and divided touch North will be at the LHS (left hand side) of the bar**

In the “single touch” method, a magnet is drawn over the rod so as to go completely over the length of the rod. The magnetic domains are then pulled into alignment with as the magnet passes. A useful method of realizing the polarity of the induced magnetism is to consider the bar as a compass and which way it would point to the magnet as it finally leaves the bar. Best results are obtained after about twenty passes. The magnet taken in a big loop away from the bar in between passes.

In the “divided touch” method two magnets are used at the same time in what may be thought of as a mirroring action. This method produces a stronger magnet than the single touch method. Beware of polarity: If this method was to be done using two similar poles facing the bar it is possible to create a bar magnet with two like poles at either end! These are termed “consequent poles”.

- **MAGNETISATION BY ELECTRIC METHOD**

Modern methods of magnetisation tend to use electrical methods as it is easily manufactured and controlled. A current passing through a coil will produce a magnetic field. The strength of the field is proportional to the current. Schematic showing conventions, many coils are required (See fig. below)



**Fig.11. 4 magnetization by electric method**

The polarity of the field is easily seen by examining the path of the conventional current in the coil. If looking at the end of the coil the current is going clockwise it will produce the “south seeking” pole. A capital “S” has the ends following the clockwise rotation. Similarly the other end will be anticlockwise. This produces the “north seeking” pole. A (albeit rounded) capital “N” has the ends following an anticlockwise rotation. These coils can be bought or made or even by modifying some “coil gun” circuits.

### 11.3.2 DEMAGNETISATION

The process used to destroy the magnetic properties of a material is called **demagnetization**

- **DEMAGNETIZATION BY HAMMERING**



**Fig.11. 5 Hammering a magnet**

Hammering a rod will either allow it to become slightly magnetic if laid along a magnetic field (i.e. North -South) but demagnetise it if laid across the field lines (East-West). **Notice that:** Do not try to improve an existing magnet by hammering,; hammering could easily reduce the field strength below that already present.

- **DEMAGNETISATION BY HEATING**

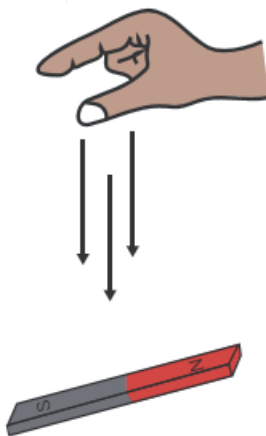
If we consider a bar magnet, the bar is heated to above a temperature (technically called the “curie point”) which varies from metal to metal, however most steels will be hotter at “red hot”. At this point the bar is no longer ferromagnetic but paramagnetic. As the bar cools it becomes ferromagnetic again and the domains are aligned with the external field.



**Fig.11. 6 Heating a magnet**

It may be of interest to try heating an old, weak magnet (all the paint will be burned off!) to red hot using a pair of tongs in a Bunsen flame and then placing it on a piece of heat mat with a rare-earth magnet underneath. Demagnetisation can be achieved by allowing the bar to cool in an East-West orientation shielded from magnetic influences.

- **DEMAGNETISATION BY ROUGH TREATMENT**



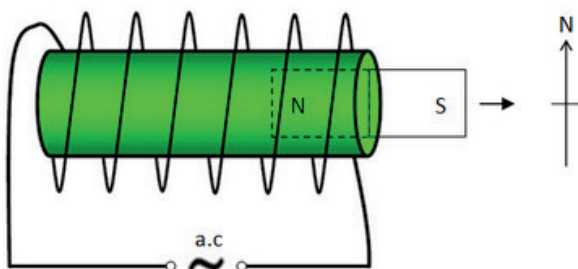
**Figure 11. 7 Dropping a magnet**

Rough handling treatment it is observed that if a magnet is subjected to rough treatment such as dropping from a height or hammering then it gradually loses part or whole of its magnetism. The rough handling disturbs

the alignment of some of molecular magnets so that the magnetization would become weak.

- **DEMAGNETISATION BY ELECTRIC METHOD**

This involves taking the bar through coil and an alternating current is used to create a field that swamps the existing field in a magnet. This is gradually reduced. This eventually becomes negligible. Alternatively the rod can be drawn out and away from a constant amplitude alternating field.



**Fig.11. 8 Demagnetization by electric method**

The whole of the coil (240 turns), should be used. Nails placed in the coil will be felt to vibrate as the voltage is brought up to 6V. The nails can be moved so that all of their length passes through the centre of the coil at this voltage. The voltage is then slowly reduced to zero. The nails should now only have minimal magnetization.

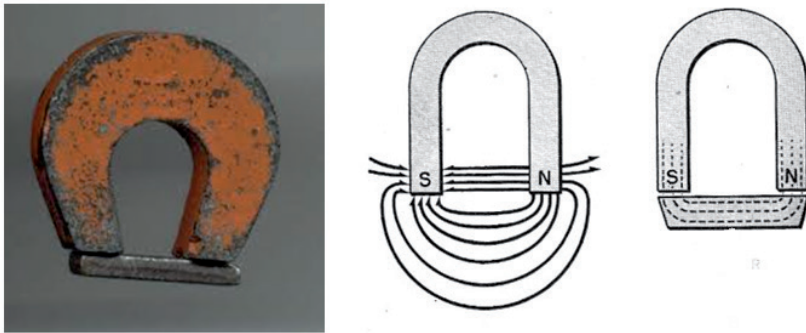
### Checking my progress

1. How do you magnetize something permanently?
2. What is the double touch method of making a magnet?
3. What are 3 methods of making magnets?
4. What are three common household items that use magnets?
5. What is the meaning of Demagnetization?
6. Can you magnetize an iron nail by stroking?



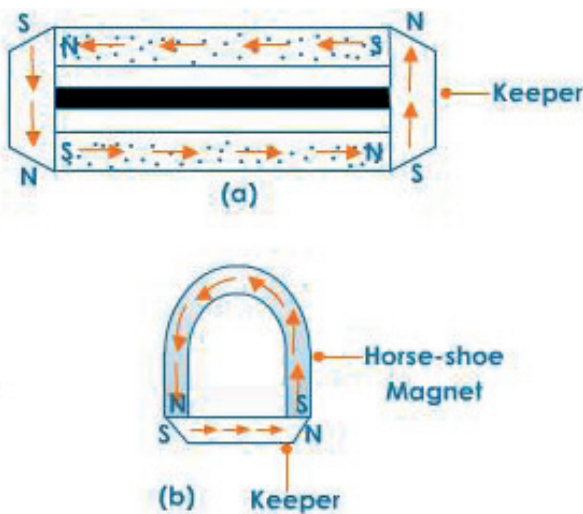
## 11.4 SOME APPLICATIONS OF MAGNETISM

### 11.4.1 Magnetic Circuit and magnetic keepers



**Fig.11. 9 Magnetic circuit**

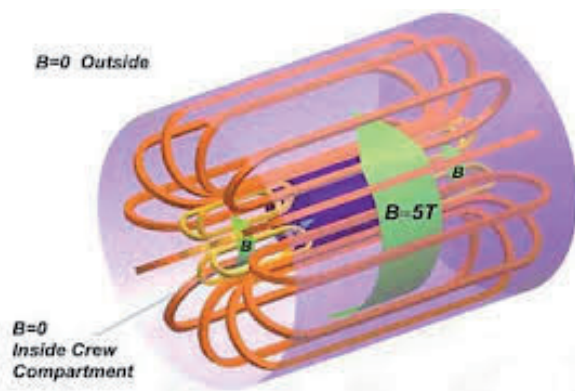
A magnetic field holds its strength best when the entire magnetic loop, or circuit, passes through a ferromagnetic metal at all points. A horseshoe magnet has an air gap between its two poles; the keeper closes this gap (see Fig.11.10). A bar magnet, left by itself, will lose its strength over several months. Though a bar magnet has no “keeper,” if you lay two bars side by side, with the north pole of one touching the south pole of the other, they form a magnetic loop in iron and preserve the strength of both magnets.



**Fig.11. 10 Magnetic keepers**

### 11.4.2 MAGNETIC SHIELDING

Equipment sometimes requires isolation from external magnetic fields. In these cases shields made of high magnetic permeability metal alloys can be used, such as sheets of permalloy and Mu-Metal, or with nanocrystalline grain structure ferromagnetic metal coatings. These materials don't block the magnetic field, as with electric shielding, but rather draw the field into themselves, providing a path for the magnetic field lines around the shielded volume. The best shape for magnetic shields is thus a closed container surrounding the shielded volume. The effectiveness of this type of shielding depends on the material's permeability, which generally drops off at both very low magnetic field strengths and at high field strengths where the material becomes saturated. So to achieve low residual fields, magnetic shields often consist of several enclosures one inside the other, each of which successively reduces the field inside it.



**Fig. 11. 11 Magnetic shielded**

Because of the above limitations of passive shielding, an alternative used with static or low frequency fields is active shielding; using a field created by electromagnets to cancel the ambient field within a volume. Solenoids and Helmholtz coils are types of coils that can be used for this purpose.

### 11.4.3 LODESTONE

A lodestone, or loadstone, is a naturally magnetized piece of the mineral magnetite ( $\text{Fe}_3\text{O}_4$ ). Ancient people first discovered the property of magnetism in lodestone. Pieces of lodestone, suspended so they could turn, were the first magnetic compasses, and their importance to early navigation is indicated by their very name, which in Middle English means “course stone” or “leading stone.” Lodestone is one of only two minerals that is found naturally magnetized; the other, pyrrhotite, is only weakly magnetic.

## 11.5 UNIT 11 ASSESSMENT

1. Complete the following statement:

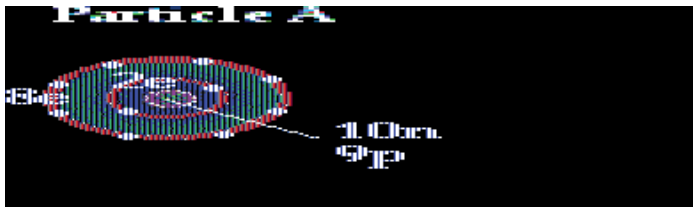
.....are the charged parts of an atom.

- |                   |                           |
|-------------------|---------------------------|
| a. Only electrons | d. Electrons and neutrons |
| b. Only protons   | e. Electrons and protons  |
| c. Neutrons only  | f. Protons and neutrons   |

2. TRUE or FALSE

- An object which is positively charged contains all protons and no electrons.
- An object which is negatively charged could contain only electrons with no accompanying protons.
- An object which is electrically neutral contains only neutrons.

3. Identify the following particles as being charged or uncharged. If charged, indicate whether they are charged positively or negatively. (n = neutron, p = proton, e = electron)



4. The amount of charge carried by a lightning bolt is estimated at 10 Coulombs. What quantity of excess electrons is carried by the lightning bolt?

5. Respond to the following student statement: "A positively charged object is an object which has an excess of positive electrons."

6. A magnet attracts a piece of iron. The iron can then attract another piece of iron. On the basis of domain alignment, explain what happens in each piece of iron.

7. Why does hitting a magnet with a hammer cause the magnetism to be reduced?

8. Examine the parts of an electric bell shown in the figure. Discuss how it works when it is switched on. Make an electric bell and exhibit it.

9. What causes the magnetism in a magnet? A bar magnet is heated. State the effect on magnetic properties.

10. What is the difference between temporary magnets and permanent magnets?

# **Electricity**

## Static Electricity



# Unit 12

## Applications of Electrostatics

### Key unit competence

---

At the end of this unit I should be able to explain applications of static charges.

### My goals

---

By the end of this unit, I will be able to:

- explain and describe distribution of electric charges and metallic conductors.
- explain electric force, electric field and electric potentials.
- discuss applications of electrostatics.
- define electric field strength.
- relate electric field patterns and charge distribution on conductors of different shapes.
- evaluate applications of electrostatics in other fields (agriculture, environment, industry).
- identify possible hazards related to electrostatics and how to avoid them.

### Key concepts

---

1. What is needed to describe electrostatics?
2. When and where can you observe the effects of electrostatics?
3. How can you avoid an electric circuit from your house?
4. How do you know the amount of electric potential from a charged body?
5. How do you calculate/tell/gauge the potential difference?
6. What do charge distributions refer to?
7. Describe different applications of electrostatics.



## Vocabulary

Electric field, electric potential, lightening arrestors, paint spray, laser printer, electrostatic precipitator, photocopy machine.



## Reading strategy

Read all the details of this unit. Perform calculations and do experimental work about an electric field. Hence, describe different application of electrostatics. Participate in all activities, be keen on procedures and observations.

## 12.1 Introduction



### Activity 12.1: Investigating the electric charges on a rubbed balloon

#### Materials:

- 2 inflated balloons with string attached
- Your hair
- Aluminium can
- Woolen fabric

#### Procedure:

- Rub the 2 balloons one by one against the woolen fabric, and then try moving the balloons together. Do the balloons want to or are they unattracted to each other?
- Rub 1 of the balloons back and forth on your hair then slowly pull it away. Ask someone nearby what they can see or if there's nobody else around try looking in a mirror and discuss your observations.
- Put the aluminum can on its side on a table, after rubbing the balloon on your hair again hold the balloon close to the can and watch as it rolls towards it, slowly move the balloon away from the can and it will follow.
- Discuss and explain the observations made.

**Electrostatics** is a branch of physics that deals with the phenomena and properties of stationary electric charges.

## 12.2 Static Electricity

A nylon garment often crackles when it is taken off. We say it has become charged with static electricity. The crackles are caused by tiny electric sparks which can be seen in the dark. Pens and combs made of certain plastics become charged when rubbed on the sleeve and can attract scraps of paper. Those materials are electrified, possess an electric charge or are electrically charged.

There are two kinds of charges in nature; negative and positive charges.

**Like charges (+ and + or – and -) repel while unlike charges (+ and -) attract**

The net amount of electric charge produced in any process is zero. This is known as the **Law of Conservation of Electric Charge**.

If one object or one region of space acquires a positive charge then an equal amount of negative charge will be found in neighbouring areas or objects.

## 12.3 Electric field

The Concept of Electric Field



### Activity 12.2: Investigation of electric field

**Materials:**

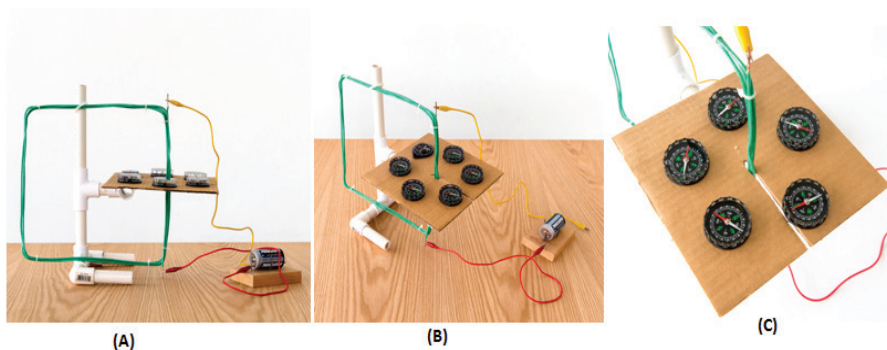
- One battery cell (1.5V)
- A conducting wire
- 5 magnetic needles
- A slotted cardboard

**Procedure:**

- Arrange the materials as shown in Fig. 12.1.
- Remove the battery and note the changes on needles.
- Reconnect the battery and note the changes on needles.

**Question:**

What is the main cause of the directions change when the battery is connected?



**Fig. 12.1:** Electric field effect on the magnetic needles

When a small charged particle is located in the area surrounding a charged object, the charged particle experiences a force in accordance with Coulomb's Law. The space around the charged object where force is exerted on the charged particle is called an **electric field** or **electrostatic field**. Theoretically, an electric field due to charge extends to infinity but its effect practically dies away very quickly as the distance from the charge increases.

### 12.3.1 Electric Field Intensity or Field Strength

The intensity of an electric field at any point is determined by the force acting on a unit positive charge (+1C) placed at that point.

If a positive point charge  $Q_0$  (also called test charge) is placed at any point in an electric field and it experiences an electric force  $F'$ , the electric field vector  $E'$  at the point is the electric force divided by the magnitude of the test charge  $Q_0$

$$E' = \frac{F'}{Q_0}$$

Electric field is an electric force per unit charge. The following points should note:

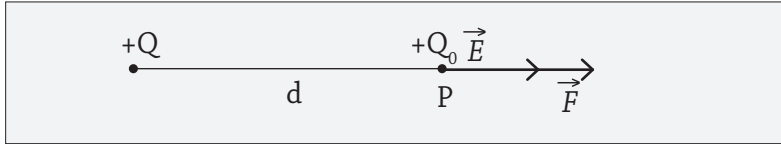
- a) The electric field is a force per unit charge, it is therefore a vector, it has both magnitude and direction.
- b) The electric field can be described (drawn) in terms of lines of force. Where the lines of force are close together, the intensity (strength) is high and where the lines are widely separated the intensity (strength) will be low.



## 12.2.2 Electric Field Intensity at a point in Electric Field

The magnitude of the electric field at any point due to a point charge can be calculated using Coulomb's Law.

- a) Lets consider point charge  $Q$ , where  $Q$  is positive.



The electric field  $E$  at point  $P$  (distance  $d$  away) due to an isolated  $+Q$  in a medium of permittivity  $\epsilon$  (measure of resistance of a medium in an electric field) can be calculated by imaging a very small charge  $+Q_0$  to be placed at  $P$ . By Coulomb's Law.

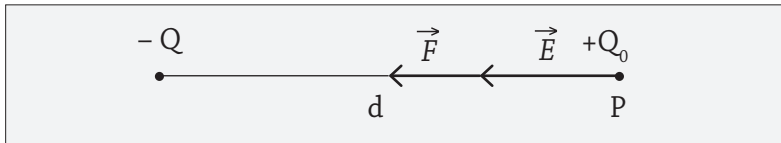
$$F = \frac{1}{4\pi\epsilon} \cdot \frac{QQ_0}{d^2}$$

where  $\epsilon$  is the permittivity of the medium between the charges.

But  $E$  is the force per unit charge:  $E = \frac{F}{Q_0}$

$$\text{Therefore } E = \frac{1}{4\pi\epsilon} \cdot \frac{Q}{d^2}$$

- b) Now consider point charge  $Q$  where  $Q$  is negative ( $-Q$ )



The electric field  $E$  at point  $P$  (distance  $d$ ) due to an isolated  $-Q$  in a medium of permittivity  $\epsilon$  can be calculated by imaging a very small charge  $+Q_0$  at  $P$ .

$$F = \frac{1}{4\pi\epsilon} \cdot \frac{-QQ_0}{d^2}$$

$$E = \frac{F}{Q_0} \therefore E = -\frac{Q}{4\pi\epsilon d^2}$$

Definition of permittivity of a medium: It is the measure of resistance of a medium in an electric field, it is denoted by Greek letter epsilon ( $\epsilon$ )

**Conclusion:** The electric field due to a point charge always points away from the positive charge but towards the negative charge.

**Example:**

Calculate the electric field intensity where the force of 2.25N acts on a charge of  $20 \times 10^{-6}$  C.

**Solution:**

$$E = \frac{F}{Q} = \frac{2.25}{20 \times 10^{-6}} = 112500 \text{ NC}^{-1}$$

## 12.4 Electric field lines

Electric field lines (or **line of force** in an electric field) are an imaginary line drawn through a region of empty space so that its tangent at any point in the direction of the electric field vector at that point. The relative closeness of the lines at some place gives an idea about the intensity of electric field at that point

The spacing of field lines gives a general idea of the magnitude of electric field intensity at each point. Where the electric field intensity is strong, the electric field lines are drawn close together and where the electric field intensity is weaker, the field lines are further apart, as shown in the figure below.

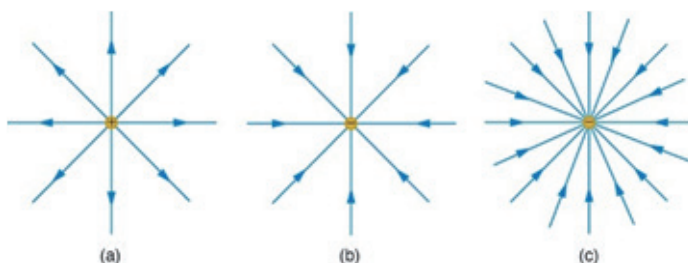
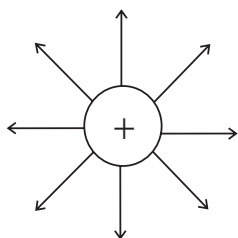


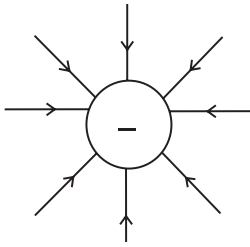
Fig 12.2 Strong and weak electric fields:

a) Electric field lines produced by a single positive point charge.



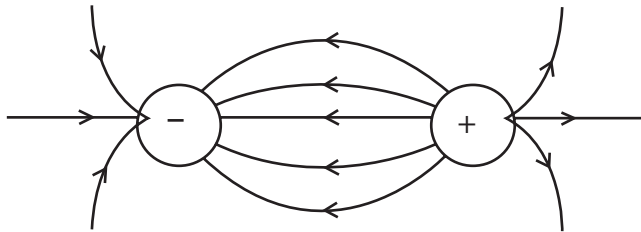
The electric field lines always point away from positive charge

b) Electric field lines produced by a single negative point charge.



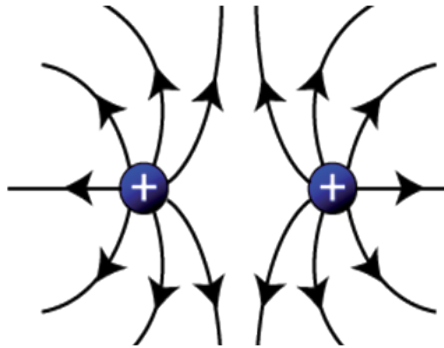
The electric field lines always point towards a negative charge.

c) Electric field lines produced by two equal and opposite point charges.

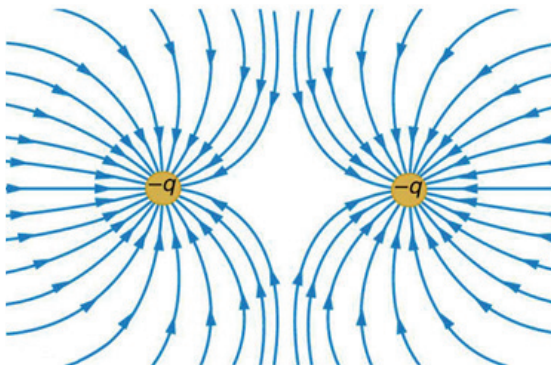


**Note:** The number of lines leaving the positive charge equals the number entering the negative charge.

d) Electric field lines for two equal and positive charges.

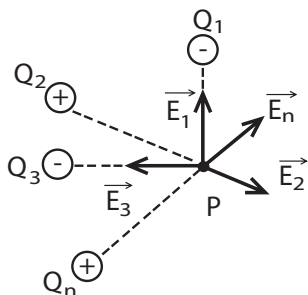


e) Electric fieldlines for equal and negative charges.



## 12.5 Electric field strength due to the distribution (superposition) of electric field

Consider many point charges,  $Q_1, Q_2, Q_3, \dots, Q_n$  and the electric field caused by the individual point charges  $E_1, E_2, E_3, \dots, E_n$  respectively. The resultant electric field at a point P is the **vector sum** of the field at P due to each point charge distribution.



$$\vec{E} = \vec{E}_1 + \vec{E}_2 + \vec{E}_3 + \dots + \vec{E}_n$$

If  $r$  is the radius of a sphere the field strength  $E$  at its surface is given by

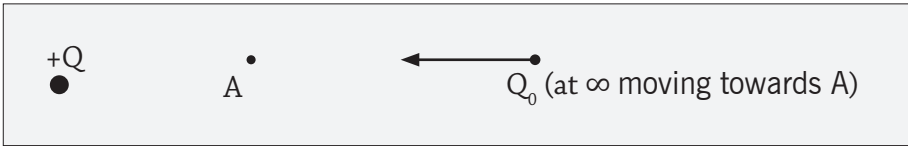
$$E = \frac{1}{4\pi\epsilon} \cdot \frac{Q}{r^2}$$

### Checking my progress

1. Like charges ..... but unlike charges do .....
2. Charges are .....
  - (A) destroyed.
  - (B) Conserved
  - (C) Reducing with time.
  - (D) Colored
3. The magnitude of electric field intensity reduces with.....
  - (a) Distance from the charge
  - (b) Force between charges
  - (c) Density of the charges and the medium around.
4. The following are properties of electric fields except.
  - (a) They do not cross
  - (b) They are always many
  - (c) Move from positive to negative
  - (d) Move from negative to positive.
5. The neutral point exists between
  - (a) All charges
  - (b) Unlike charges
  - (c) Like charges
  - (d) Two poles.

## 12.6 Electric potential

Every charge has an electric force which extends theoretically up to infinity. Let us consider an isolated charge  $+Q$  fixed in space:



If a test charge  $Q_0$  is placed at infinity, the force on it due to charge  $+Q$  is zero.

$$F = 9 \times 10^9 \frac{QQ_0}{d^2}, \text{ as } d \rightarrow \infty, F \rightarrow 0$$

If the test charge  $Q_0$  at infinity is moved towards  $+Q$  a force of repulsion acts on it and hence work is required to be done to bring it to a point like A. The work done by the electric force does not depend on the path taken by charge  $Q_0$ , it is only dependent on the initial and final position, i.e. the electric force is conserved and the work done can be expressed in terms of potential energy,  $U$ .

The work done in bringing  $Q_0$  from infinity to A is given by:

$$W = F \cdot d = \frac{QQ_0}{4\pi\epsilon d^2} \cdot d$$

$$W = \frac{QQ_0}{4\pi\epsilon d}$$

Then:

$$\begin{aligned} W_{\infty-A} &= U_B - U_A = -(U_A - U_\infty) \\ &= -\Delta U \quad (\Delta U = \text{change in energy}) \end{aligned}$$

Where:

$$U_\infty = \frac{QQ_0}{4\pi\epsilon d_\infty}$$

Is the potential energy of the test charge  $Q_0$  at  $d = \infty$

$$U_A = \frac{QQ_0}{4\pi\epsilon d_A}$$

Is the potential energy of the test charge  $Q_0$  at  $d = A$

Hence, the electric potential energy  $U$  of a test charge  $Q_0$  placed at distance  $d$  from the charge  $+Q$  is given by

$$U = \frac{QQ_0}{4\pi\epsilon d}$$

The electric potential  $V$  at a point distance  $d$  from the charge  $Q$  is the electric potential energy  $U$  per unit charge associated with a test charge  $Q_0$  placed at that point:

$$V = \frac{U}{Q_0}, \text{ and } U = \frac{QQ_0}{4\pi\epsilon_0 d}$$

Then

$$V = \frac{QQ_0}{4\pi\epsilon_0 d Q_0} = \frac{Q}{4\pi\epsilon_0 d}$$

Hence, electric potential at a point in an electric field is the amount of work done in bringing a unit of positive charge from infinity to that point, i.e.

$$V = \frac{\text{Work}}{\text{Charge}} = \frac{W}{Q}$$

Where  $W$  is the work done to bring a charge of Coulomb from infinity to the point of consideration.

### Examples:

1. 50 coulombs of charge is brought from infinity to a given point in an electric field when 62.5J of work is done. What is the potential at that point?

#### Solution:

$$V = \frac{\text{Work}}{Q} = \frac{62.5}{50} = 1.25 \text{ volts.}$$

2. Calculate the electric potential at a point a distance 2m from a point charge of 0.0000004C placed in a free space.

#### Solution:

$$V = k \frac{Q}{d} = 9.0 \times 10^9 \times \frac{0.0000004}{2} = 1800 \text{ volts.}$$

**Unit:** The SI unit of electric potential is volt (V) and may be defined as:

**“The potential at a point in an electric field is 1 volt if 1 joule of work is done in bringing a unit of positive charge from infinity to that point against the electric field.”**

### 12.6.1 Electric Potential Difference

In practice we are more concerned with potential difference (p.d.) between two points rather than their individual absolute potential. The potential difference, p.d., between two points may be defined as:

**“The potential difference between two points is the amount of work done in moving a unit of positive charge (+1C) from the point of lower potential to the point of higher potential.”**

Consider two points A and B in the electric field of a charge +Q as shown here:



The potential,  $V_1$ , at B means that  $V_1$  joules of work have been done in bringing a unit of positive charge from infinity to B. Let the extra work to bring the unit of positive charge (+1C) from B to A be in joules, therefore:

$$\text{Potential at A} = V_2 = V_1 + W$$

The p.d. between A and B is equal to  $V_2 - V_1 = V_1 + W - V_1 = W$

The SI unit of p.d. is Volt and may be defined as:

“The p.d. between two points is 1V if 1 joule of work is done in bringing a unit of positive charge (+1C) from the point of lower potential to the point of higher potential.”

Let  $V$  be the potential difference between point A and B:

$$V = V_2 - V_1$$

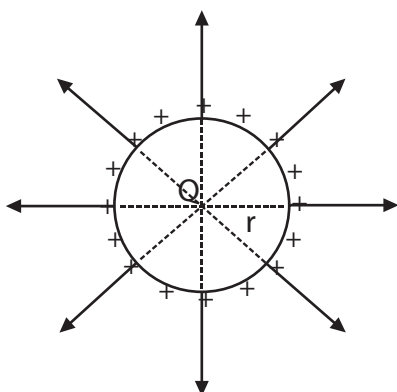
By definition:

$$V = \frac{W}{Q} \text{ then } V_2 - V_1 = \frac{W}{Q}$$

So the work done is  $W = Q(V_2 - V_1)$

Which is the work done for bringing a positive charge  $Q$  from B to A.

## 12.6.2 Potential of a Charged Sphere



Consider an isolated sphere of radius  $r$  metres placed in air and charged uniformly with  $Q$  Coulombs. The field has spherical symmetry i.e., lines of force spread out normally from the surface and meet at the centre of the sphere if projected backward. Outside the sphere, the field is exactly the same as though the charge  $Q$  on the sphere were concentrated at its centre.

**Fig. 12.2:** Field lines of a charged sphere

### (i) Potential at the Sphere Surface

Due to the spherical symmetry of the field, we can imagine the charge  $Q$  on the sphere concentrated at its centre,  $O$ . The problem then reduces to finding the potential at a point  $r$  metres from a charge  $Q$ .

$\therefore$  Potential at the surface of sphere ( $V_s$ )

$$V_s = \frac{Q}{4\pi\epsilon r} = 9 \times 10^9 \frac{Q}{r} \text{ Volts (in vacuum or air)}$$

If the sphere is placed in medium ( $\epsilon_n$ ) then;

$$V = \frac{Q}{4\pi\epsilon_n r} = 9 \times 10^9 \frac{Q}{\epsilon_n r}$$

### (ii) Potential Outside the Sphere

Consider a point  $P$  outside the sphere. Let this point  $P$  be at a distance of  $D$  metres from the surface.

Then potential at  $P$ :

$$V_p = 9 \times 10^9 \frac{Q_o}{D + r} \text{ Volts (in vacuum or air)}$$

### (iii) Potential Inside the Sphere

Since there is no electric flux inside the sphere, the electric field inside the sphere is zero. Hence all points inside the sphere are at the same potential as the points on the surface.

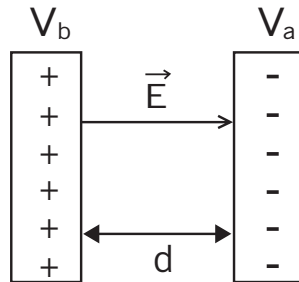


**Note:** Electric potential is a scalar quantity therefore electric potential at a point due to a number of charges is equal to the algebraic sum of potentials due to each charge.

- It should be noted from equation  $V = \frac{1}{4\pi\epsilon d} \frac{Q}{d}$  that the potential due to a positive charge is negative.
- All points equidistant from a point charge have the same potential.
- If a point lies on an equipotential surface the electric field at that point is perpendicular to the surface (a surface over which potential is constant is called an equipotential surface).

## 12.7 Relationship between E and V

The effect of any charge distribution can be described either in terms of the electric field or in terms of the electric potential. Electric potential is often easier to use since it is a scalar, whereas electric field is a vector.



**Fig. 12.3:** Electric field between two charged plates

The relationship between E and V for the case of a uniform electric field such as that between parallel plates whose p.d. is V where  $V = V_b - V_a$ . The work done by the electric field to move a positive charge Q from a to b is  $W = Q \int_a^b -V_a$

We can also write the work done in terms of force, F, where  $F = QE$ . Thus  $W = F \cdot d = Q \cdot E \cdot d$

E is uniform electric field and d is the distance between parallel plates.

Thus  $Q(V_b - V_a) = Q \cdot E \cdot d$

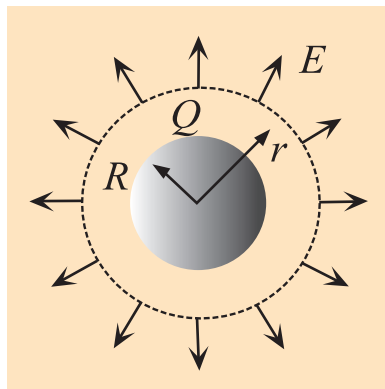
Or  $V_b - V_a = Ed$

Solving for E

$$E = \frac{V_b - V_a}{d} \text{ or } E = \frac{V}{d} \left( \frac{\text{Volt}}{\text{metre}} \right)$$

## 12.8 Charge distribution

### 12.8.1 The Electric Field of a Conducting Sphere



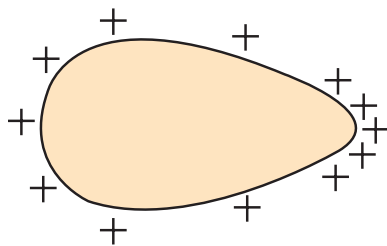
The electric field of a conducting sphere with charge  $Q$  can be obtained by a straightforward application of Gauss' law. Considering a Gaussian surface in the form of a sphere at radius  $r > R$ , the electric field has the same magnitude at every point of the surface and is directed outward. The electric flux is then just the electric field times the area of the spherical surface.

**Fig. 12.4:** The Electric field of a Conducting Sphere

$$\Phi = EA = E4\pi r^2 = \frac{Q}{\epsilon_0}$$

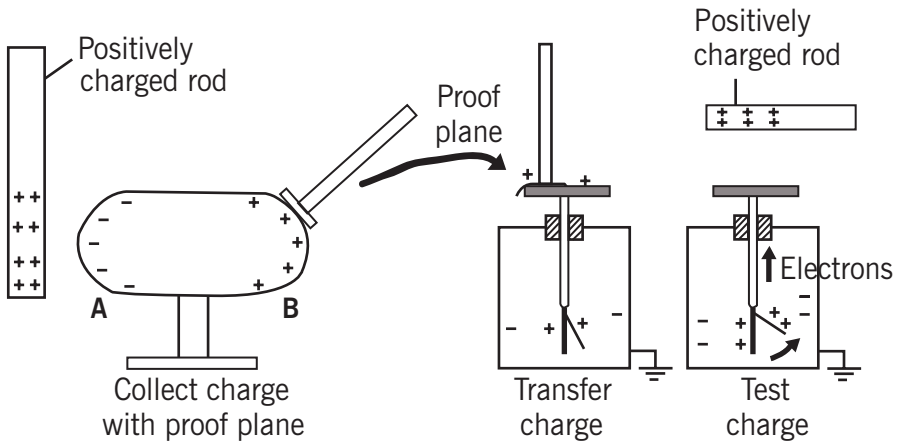
### 12.8.2 Distribution of Charge over the Surface of a Closed Conductor (Pear)

The charge around the conductor is measured using a proof plane. The proof plane is a small brass disc on an insulated handle.



**Fig. 12.5:** Distribution of charge on a pear-shaped closed conductor

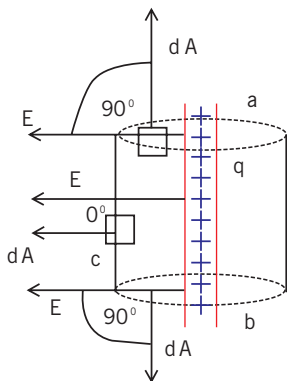
It is first earthed to ensure there is no charge on the disc. The proof plane is then touched onto the surface of the conductor. The proportion of charge acquired by the disc when it is touched onto the surface of the conduction is proportional to the surface charge density of the conductor. The charge can be measured by touching the brass disc of the proof plane on the inside of a metal can standing on the top of the cap of a gold leaf electroscope. The deflection is an indication of the charge at the surface at that point.



**Fig. 12.6:** Transfer of charges to a proof plane

If this process is repeated at various positions on the conductor, it is found that the least charge is found where the radius of the curvature of the conductor is greatest and that the charge is greatest where the surface of the conductor has the smallest radius of the curvature, i.e. where it is most pointed. If the radius of the curvature is very small, the density of charge can be large enough for charge leakage to occur creating a wind of ions.

### 12.8.3 Distribution of Charge over the Surface of a cylindrical Conductor



**Fig. 12.7:** Cylindrical conductor

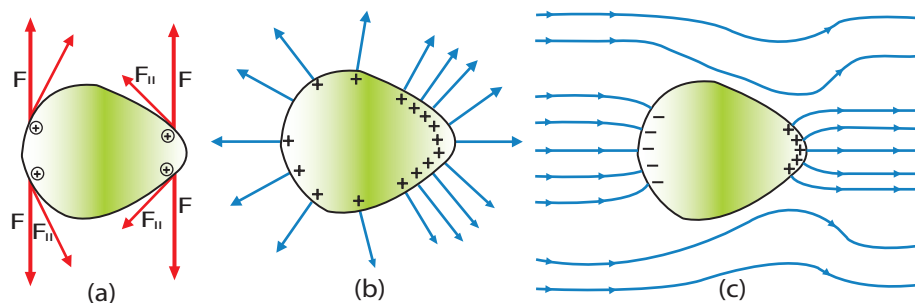
A cylindrical Gaussian surface is used when finding the electric field or the flux produced by any of the following:

- An infinitely long line of uniform charge
- An infinite plane of uniform charge
- An infinitely long cylinder of uniform charge

As example “field near infinite line charge” is given on the left;

### 12.8.4 Distribution of Charge over the Surface of a sharp point

Conductors are materials in which charges can move freely. If conductors are exposed to charge or an electric field, their internal charges will rearrange rapidly. For example, if a neutral conductor comes into contact with a rod containing a negative charge, some of that negative charge will transfer to the conductor at the point of contact. But the charge will not stay local to the contact point -- it will distribute itself evenly over the surface of the conductor. Once the charges are redistributed, the conductor is in a state of electrostatic equilibrium. It should be noted that the distribution of charges depends on the shape of the conductor and that static equilibrium may not necessarily involve an even distribution of charges, which tend to aggregate in higher concentrations around sharp points. This is explained in Fig. 12.8;



**Fig. 12.8:** Electrical Charge at a Sharp Point of a Conductor

Forces between like charges at either end of the conductor are identical, but the components of the forces parallel to the surfaces are different. The component parallel to the surface is greatest on the flattest surface and therefore moves charges away from one another more freely. This explains the difference in concentration of charge on flat vs. pointed areas of a conductor.

Similarly, if a conductor is placed in an electric field, the charges within the conductor will move until the field is perpendicular to the surface of the conductor. Negative charges in the conductor will align themselves towards the positive end of the electric field, leaving positive charges at the negative end of the field. The conductor thus becomes polarised, with the electric field becoming stronger near the conductor but disintegrating inside it. This occurrence is similar to that observed in a Faraday cage, which is an enclosure made of a conducting material that shields the inside from an external electric charge or field or shields the outside from an internal electric charge or field.

## Checking my progress

1. Electric flux is calculate using  
E. Flux = EA  
(a) True  
(b) False
2. Electric charges tend to concentrate much at sharp points.  
(a) True  
(b) False.
3. The charges are normally distributed unevenly on a charged metal sphere  
(a) True  
(b) False
4. The electric potential of a charge in a vacuum at a distance of 1m from the charge is.....  
(a) 99000  
(b) 9900V  
(c) 89kV  
(d) 99kV

## 12.9 Application of electrostatics

### 12.9.1 Point discharge (Lightening)

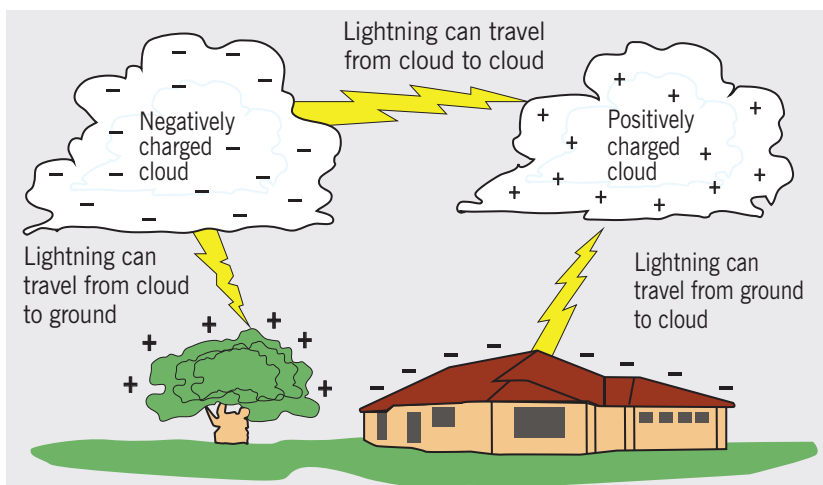


#### Activity 12.3: Lightening description

Take the case of the phenomena of lightening and thunderstorm, and then answer to the following questions.

#### Questions:

1. What do you think are lightening and thunderstorm?
2. Suggest the causes of thunderstorm and lighting.
3. Discuss and explain how one can create a protection from lightening and thunderstorm.



**Fig. 12.9:** *Lightening*

**Lightening** is a sudden electrostatic discharge during an electrical storm between electrically charged regions of a cloud (called intra-cloud lightening or IC), between that cloud and another cloud (CC lightening), or between a cloud and the ground (CG lightening).

The charged regions in the atmosphere temporarily equalise themselves through this discharge referred to as a **strike** if it hits an object on the ground, and a **flash** if it occurs within a cloud. Lightening causes light in the form of plasma, and sound in the form of thunder. Lightening may be seen and not heard when it occurs at a distance too great for the sound to carry as far as the light from the strike or flash. For the case of RWANDA, it is taken as the world’s place with high potential of lightening and thunderstorms.

### 12.8.2 Lightning Arrestors

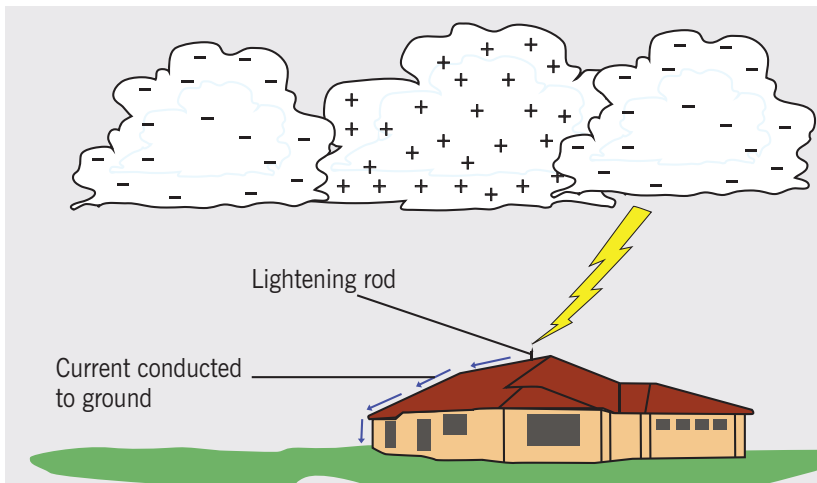


#### **Activity 12.4: Visiting lightning arrestors**

Visit any building which has lightning arrestors and answer the following questions.

**Questions:**

1. Why do people use lightning arrestors on their houses/buildings?
2. How and when do you think lightning arrestors work?



**Fig. 12.10:** *Lightening Arrestors*

A **lightening arrester** is a device used on electrical power systems and telecommunication systems to protect the insulation and conductors of the system from the damaging effects of lightning. The typical lightening arrester has a high-voltage terminal and a ground terminal. When a lightning surge (or switching surge, which is very similar) travels along the power line to the arrester, the current from the surge is diverted through the arrester, in most cases to earth.

In telegraphy and telephony, a lightning arrester is placed where wires enter a structure, preventing damage to electronic instruments within and ensuring the safety of individuals near them. Smaller versions of lightning arresters, also called surge protectors, are devices that are connected between each electrical conductor in power and communication systems and the Earth. These prevent the flow of the normal power or signal currents to ground, but provide a path over which high-voltage lightning current flows, bypassing the connected equipment. Their purpose is to limit the rise in voltage when a communication or power line is struck by lightning or is near to a lightning strike.

If protection fails or is absent, lightning that strikes the electrical system introduces thousands of kilovolts that may damage the transmission lines, and can also cause severe damage to transformers and other electrical or electronic devices. Lightning-produced extreme voltage spikes in incoming power lines can damage electrical home appliances or even cause death.

## Components



**Fig. 12.11:** *The Simple spark gap device diverts lightning strike to the ground (earth)*

A potential target for a lightning strike, such as a television antenna, is attached to the terminal labelled A in the photograph. Terminal E is attached to a long rod buried in the ground. Ordinarily no current will flow between the antenna and the ground because there is extremely high resistance between B and C, and also between C and D. The voltage of a lightning strike, however, is many times higher than that needed to move electrons through the two air gaps. The result is that the electrons go through the lightning arrester rather than travelling on to the television set and destroying it.

A lightning arrester may be a spark gap or may have a block of a semiconducting material such as silicon carbide or zinc oxide. “Thyrite” was once a trade name for the silicon carbide used in arresters. Some spark gaps are open to the air, but most modern varieties are filled with a precision gas mixture, and have a small amount of radioactive material to encourage the gas to ionize when the voltage across the gap reaches a specified level. Other designs of lightning arresters use a glow-discharge tube (essentially like a neon glow lamp) connected between the protected conductor and ground, or voltage-activated solid-state switches called varistors or MOVs.

Lightning arresters built for power substation use are immense devices, consisting of a porcelain tube several feet long and several inches in diameter, typically filled with discs of zinc oxide. A safety port on the side of the device vents the occasional internal explosion without shattering the porcelain cylinder.

Lightning arrestors are rated by the peak current they can withstand, the amount of energy they can absorb.



## 12.9.3 Paint spraying, Photocopy Machines/ Xerography and Laser Printers

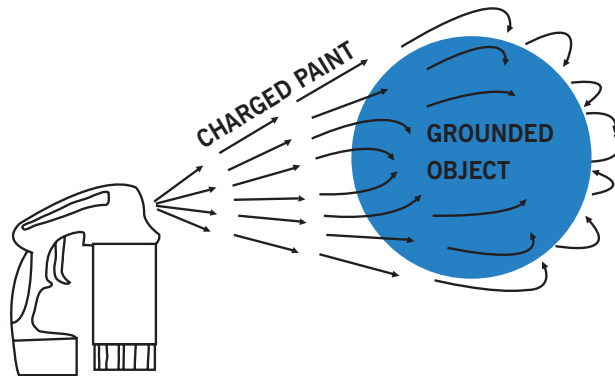
### 12.9.3.1 Paint Spraying



**Fig. 12.12:** A Paint sprayer

**Electrostatic spray painting** can reduce the problems of uneven coverage and overspray that result from using a regular spray painter. The paint is **electrostatically charged** in a couple of different ways. One type of system applies a negative electric charge to the paint while it is in the reservoir. Other systems apply the charge in the barrel of the spray painter gun.

The paint is propelled through the gun, rubbing against the side, and gaining a static electric charge.



**Fig. 12.13:** The function paint spraying

Since the paint particles all have the same charge, they repel each other. This helps to distribute the paint particles evenly and get uniform coverage. Usually the object being painted is metal and grounded but almost any product can be finished electrostatically. A metal object may need to be placed behind the object to create a ground or it can be sprayed with a conductive primer. The paint particles have a charge so they are attracted to the opposite charge of the object being painted. This makes the particles less likely to stay in the air.

Electrostatic spray painting has distinct advantages. It creates a strong bond. It also covers a three dimensional object more evenly with a good edge and wrap around coverage. It saves paint by using the least amount of paint since it has a high transfer efficiency. Also the finish will look better because it has a uniform paint thickness.

There are some disadvantages as well. Material to be sprayed must be conductive or made conductive for bonding. Care has to be taken with this equipment as guns can be delicate and bulky. It requires the use of grounding as improper usage can be a safety or fire hazard. Lastly it is more expensive to apply than regular spray painting.

### 12.9.3.2 Photocopy Machines /Xerography



#### Activity 12.5: Printers and photocopier

- Visit a printing stationary shop, where they do printing and photocopy and then discuss about the following questions.
- Tell the shop keeper to show you different parts of a printer and photocopier.

#### Questions:

1. List and describe the different machines you have seen.
2. Discuss and explain how a printer and photocopier function.
3. Explain and discuss the functions of the following parts in application of electrostatics:
  - a) Scanner
  - b) Cartridge
  - c) Fuse
  - d) Toner
4. Differentiate a printer from a photocopier.

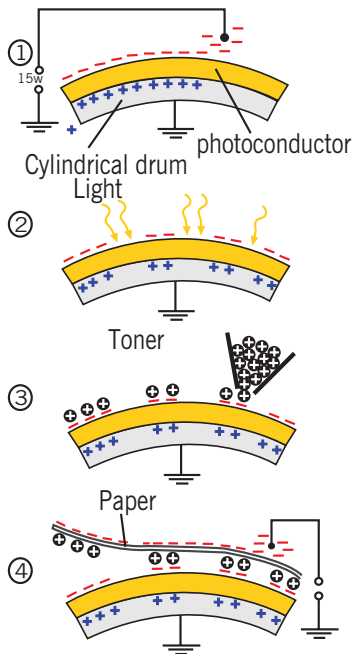


**Fig. 12.14:** Photocopier

A **photocopier** (also known as a **copier** or **copy machine**) is a machine that makes paper copies of documents and other visual images quickly and cheaply. Most current photocopiers use a technology called *xerography*, a dry process that uses electrostatic charges on a light sensitive photoreceptor to first attract and then transfer toner particles (a powder) onto paper in the form of an image. Heat, pressure or a combination of both is then used to fuse the toner onto the paper. (Copiers can also use other technologies such as ink jet, but xerography is standard for office copying.)

**Xerographic office photocopying** was introduced by Xerox in 1959, and it gradually replaced copies made by Verifax, Photostat, carbon paper, mimeograph machines, and other duplicating machines.

### How it works (using xerography)



Photocopying is widely used in the business, education, and government sectors. While there have been predictions that photocopiers will eventually become obsolete as information workers increase their use of digital document creation, storage and distribution, and rely less on distributing actual pieces of paper, as of 2015, photocopiers continue to be widely used. In the 2010s, there is a convergence in some high-end machines between the roles of a photocopier, a fax machine, a scanner, and a computer network-connected printer. As of 2015, some high-end machines can copy and print in colour.

**Fig. 12.15:** *The function of a Photocopier*

Schematic overview of the xerographic photocopying process:

1. **Charging:** The cylindrical drum is electrostatically charged by a high voltage wire called a corona wire or a charge roller. The drum has a coating of a photoconductive material. A photoconductor is a semiconductor that becomes conductive when exposed to light.
2. **Exposure:** A bright lamp illuminates the original document, and the white areas of the original document reflect the light onto the surface of the photoconductive drum. The areas of the drum that are exposed to light become conductive and therefore discharge to the ground. The area of the drum not exposed to light (those areas that correspond to black portions of the original document) remains negatively charged.
3. **Developing:** The toner is positively charged. When it is applied to the drum to develop the image, it is attracted and sticks to the areas that are negatively charged (black areas), just as paper sticks to a balloon with a static charge.

4. **Transfer:** The resulting toner image on the surface of the drum is transferred from the drum onto a piece of paper with a higher negative charge than the drum.
5. **Fusing:** The toner is melted and bonded to the paper by heat and pressure rollers.

A negative photocopy inverts the colours of the document when creating a photocopy, resulting in letters that appear white on a black background instead of black on a white background. Negative photocopies of old or faded documents sometimes produce documents which have better focus and are easier to read and study.

### 12.9.3.3 Application of Electrostatics in Laser Printer

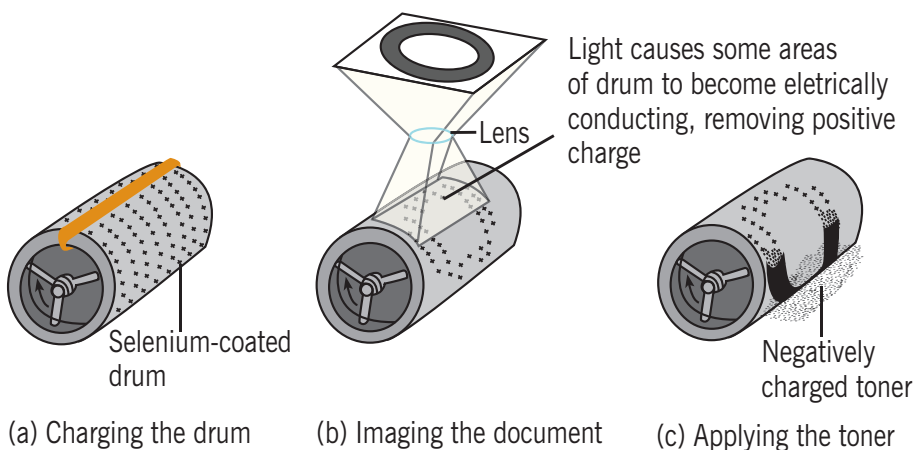


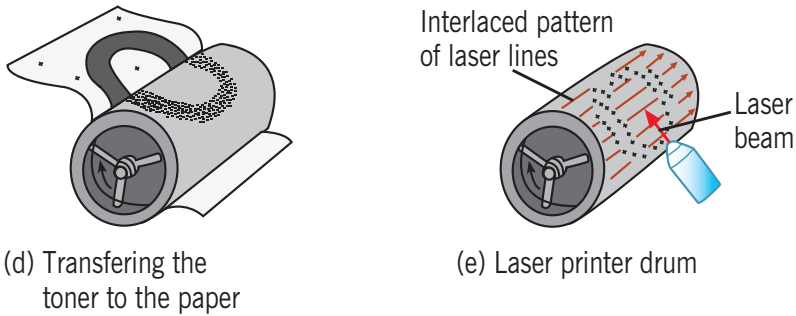
#### Activity 12.6: The printing process with laser printer

Observe the process shown in Fig.12.20 and then try to interrupt the laser printer when it has started printing and ask someone to help in opening the printer and remove the cartridge; and check on the cylinder of the cartridge.

#### Questions:

Comment and discuss your observations.





**Fig. 12.16:** *The xerography process*

The xerography process:

- a) The photoconductive surface of the drum is positively charged.
- b) Through the use of light source and lenses, an image is formed on the surface in the form of positive charges.
- c) The surface containing the image is covered with a negatively charged powder, which adheres only to the image area.
- d) A piece of paper placed over the charged powder migrates to the paper. The paper is then heat-treated to fix the powder.
- e) A laser printer operates similarly except that the image is produced by turning a laser beam on and off as it sweeps across the selenium-coated drum.

**Laser printing** is an electrostatic digital printing process. It produces high-quality texts and graphics (and moderate-quality photographs) by repeatedly passing a laser beam back and forth over a negatively charged cylinder called a “drum” to define a differentially-charged image. The drum then selectively collects electrically charged powdered ink (toner), and transfers the image to paper, which is then heated in order to permanently fuse the text and/or imagery. As with digital photocopiers and multifunction/all-in-one inkjet printers, laser printers employ a xerographic printing process. However, laser printing differs from analog photocopiers in that the image is produced by the direct scanning of the medium across the printer’s photoreceptor. This enables laser printing to copy images more quickly than most photocopiers.

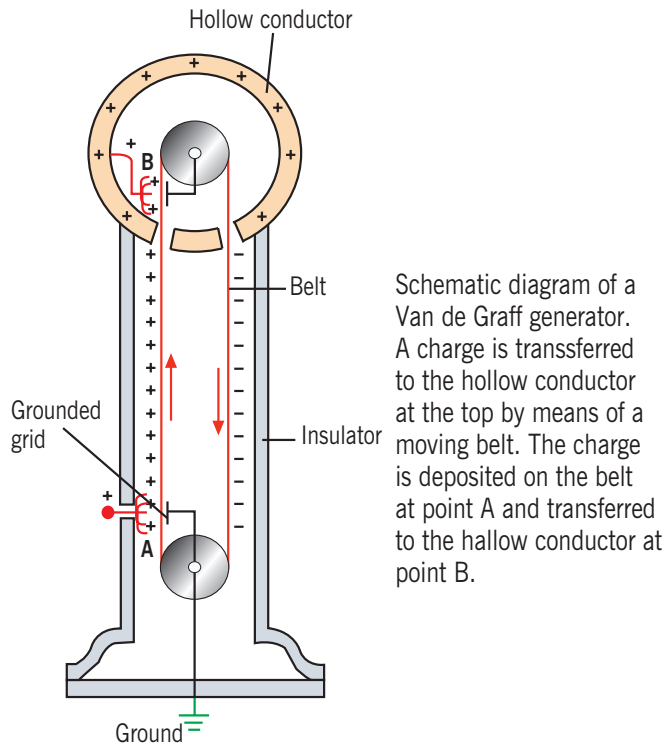
## 12.10 Van de Graff generator, electrostatic precipitator

---

### 12.10.1 The Van de Graff Generator

When a charged conductor is placed in contact with the inside of a hollow conductor, all of the charge conductor is transferred to the hollow conductor. In principle, the charge on the hollow conductor and its electric potential can be increased without limit by repetition of the process.

This type of generator is used extensively in nuclear physics research. A schematic representation of the generator is given in Figure 12.21. Charge is delivered continuously to a high-potential electrode by means of a moving belt of insulating material. The high-voltage electrode is a hollow conductor mounted on an insulating column. The belt is charged at a point by means of a corona discharge between comb-like metallic needles and a grounded grid. The needles are maintained at a positive electric potential of typically  $10^4$  V. The positive charge on the moving belt is transferred to the hollow conductor by a second comb of needles at point B. Because the electric field inside the hollow conductor is negligible, the positive charge on the belt is easily transferred to the conductor regardless of its potential. In practice, it is possible to increase the electric potential of the hollow conductor until the electrical discharge occurs through the air. Because the “breakdown” electric field in air is about  $3 \times 10^6$  V/m, a sphere 1m in radius can be raised to a maximum potential of  $3 \times 10^6$  V. The potential can be increased further by increasing the radius of the hollow conductor and by placing the entire system in a container filled with high-pressure gas.



**Fig. 12.17:** *The Van de Graaff generator*

Van de Graaff generators can produce potential differences as large as 20 million volts. Protons accelerated through such large potential differences receive enough energy to initiate nuclear reactions between themselves and various target nuclei. Smaller generators are often seen in science classrooms and museums. If a person insulated from the ground touches the sphere of a Van de Graaff generator, his or her body can be brought to a high electric potential. The hair acquires a net positive charge, and each strand is repelled by all the others. The result is a scene such as that depicted in the Fig. 12.17.

In addition to being insulated from the ground, the person holding the sphere is safe in this demonstration because the total charge on the sphere is very small (on the order of  $1\mu\text{C}$ ). If this amount of charge accidentally passed from the sphere through the person to the ground, the corresponding current would do no harm.



## Activity 12.7: Threadlike flows of electric wind

When placed in a strong e-field, human hair, eyelashes, and other sharp objects create tiny coronas which emit "electric wind". These invisible flows of air are extremely narrow and rapid, and their effects can be made visible by using dry-ice fog. (Fig. 12.18)

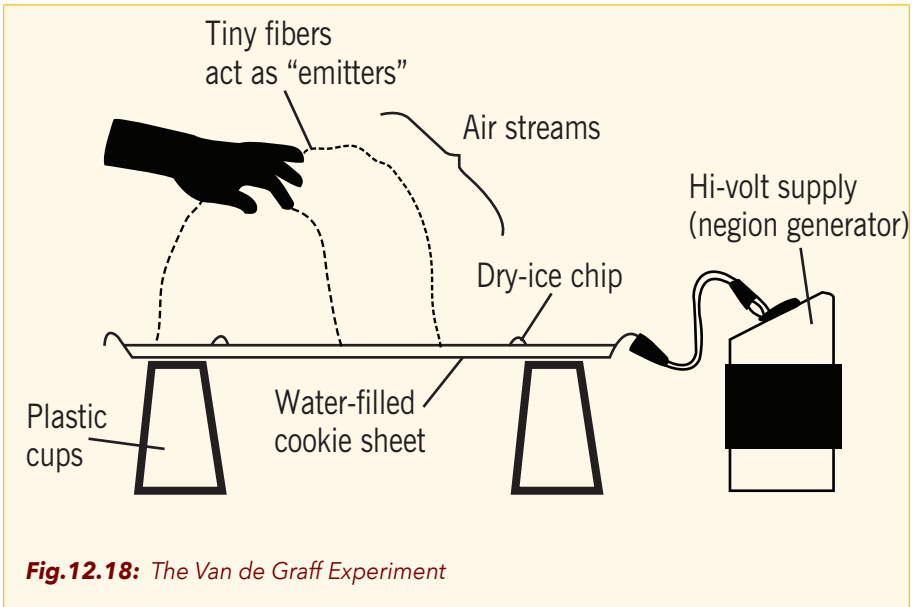
### Materials:

- A VDG ( Van de Graaf ) machine
- Wire and tape (or clip-leads)
- Tray of warm water sitting on an insulator
- Chips of dry ice
- Dark paper (submerged in the water for contrast)

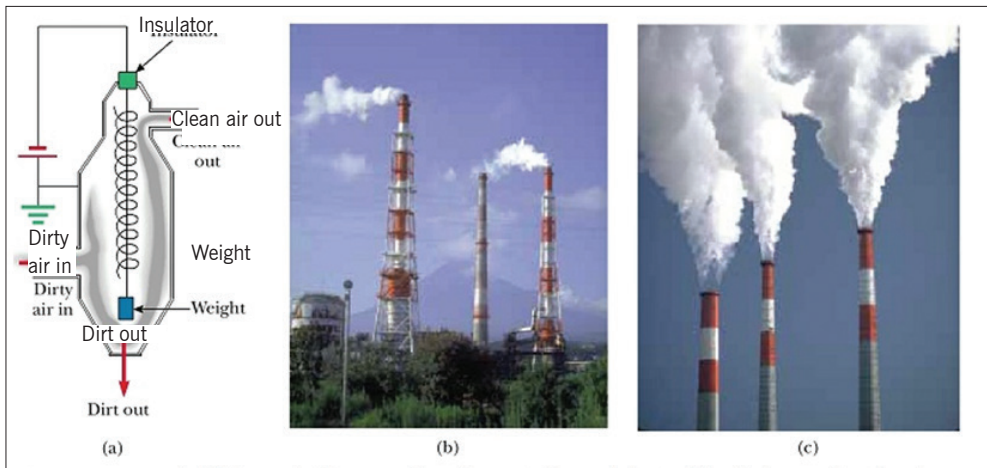
### Procedure:

- Drop several  $\text{CO}_2$  chips in the water so that a thin layer of fog forms.
- Use tape and a wire to connect the tray to the sphere of your VDG. Charge the tray with respect to the ground.
- Move your hand slowly over the fog, keeping your hand a few centimeters above it. You'll see small mysterious furrows being carved in the fog by the invisible, narrow threads of "electric wind."
- If your hands are extremely clean (no sharp microscopic defects), try wetting your fingers and brush them across fuzzy clothing to pick up some microscopic lint. Or instead try waving a torn bit of paper over the mist. The sharp paper fibers seem to generate these "threads" of charged air fairly well. If humidity is very low, then perhaps the paper should be made moist.
- Wave your hand fast, and the spots in the mist will follow your hand's motions. Pull your hand back, and the spots still appear.
- Form a "thread", then wave a charged object near it. The spot in the mist moves, indicating that the "thread" is being deflected.
- Use a soda straw to blow hard across a "thread". The corresponding spot in the mist will move only a small amount.
- Drop some short (1cm) pieces of hair onto the charged water surface. They will stand on one end, emit "threads" upwards, and narrow flows of entrained mist will be seen to project upwards from the fog layer.





### 12.10.2 The Electrostatic Precipitator



One important application of electrical discharge in gases is the electrostatic precipitator. This device removes particulate matter from combustion gases, thereby reducing air pollution. Precipitators are especially useful in coal-burning power plants and in industrial operations that generate large quantities of smoke. Current systems are able to eliminate more than 99% of the ash from smoke.

Figure 12.19 shows a schematic diagram of an electrostatic precipitator. A high potential difference (typically 40 kV to 100 kV) is maintained between

a wire running down the center of a duct and the walls of the duct, which are grounded. The wire is maintained at a negative electric potential with respect to the walls, so the electric field is directed toward the wire. The values of the field near the wire become high enough to cause a corona discharge around the wire; the discharge ionizes some air molecules to form positive ions, electrons, and such negative ions as  $O_2^-$ . The air to be cleaned enters the duct and moves near the wire. As the electrons and negative ions created by the discharge are accelerated toward the outer wall by the electric field, the dirt particles in the air become charged by collisions and ion capture. Because most of the charged dirt particles are negative, they too are drawn to the duct walls by the electric field. When the duct is periodically shaken, the particles break loose and are collected at the bottom. In addition to reducing the level of particulate matter in the atmosphere (compare Figs. 12.19b and c), the electrostatic precipitator recovers valuable materials in the form of metal oxides.



### Activity 12.8: Investigating electrostatic precipitator

#### Materials:

- $\frac{1}{2}$  Teaspoon ground black pepper (or small bits of paper)
- 1 balloon
- 1 sheet of white paper

OR

- Ground black pepper
- 1 piece of plastic (PVC) tubing, 90-150cm long, 6.5cm in diameter
- 1 plastic shopping bag.
- 1 sheet of white paper.

#### Procedure:

1. Give each learner a balloon and some black pepper on a sheet of paper.
2. Ask the students to blow up their balloons and rub them on their hair or a piece of cloth.
3. Hold the balloon over the pepper on the paper. What happens to the pepper? See Fig. 12.20



**Fig.12. 20:** Materials required for the balloon model electrostatic precipitator.  
*Close-up of pepper grains on the balloon surface.*

4. Record your observation.
5. Pull the plastic grocery bag through the PVC tube so that the inside edge of it becomes charged with static electricity.
6. Gently pour some pepper through the tube while holding it over a piece of white paper. Some pepper should stick to the inside of the tube (in the same way that it was attracted to the balloon).
7. Note your observations.

**Questions:**

1. Does the electrostatic precipitator remove all of the particulates?
2. How does this compare to the efficiency of a wet scrubber?  
Which one is better?
3. If the precipitators are more efficient, why would you ever want to use a wet scrubber?

## 12.11 Unit 12 assessment

1. Two small spheres spaced 35.0cm apart have equal charge. How many excess electrons must be present on each sphere if the magnitude of the force of repulsion between them is  $2.20 \times 10^{-21}\text{N}$ ?
2. A point charge  $q_1 = -7 \text{ nC}$  is at the point  $x_1 = 0.6\text{m}, y_1 = 0.8 \text{ m}$ , and a second point charge  $q_2 = 4 \text{ nC}$  is at the point, . Find the magnitude and direction of the net electric field at the origin.  $x_2 = 0.6 \text{ m}$  and  $y_2 = 0\text{m}$
3. What must the charge (sign and magnitude) of a particle of mass 5g be for it to remain stationary when placed in a downward-directed electric field of magnitude 800nC?
4. What is the magnitude of an electric field in which the electric force on a proton is equal in magnitude to its weight?
5. A particle has a charge of  $-8.00\text{nC}$ . Find the magnitude and direction of the electric field due to this particle at a point 0.5m directly above it.
6. Two particles having charges of  $0.70\text{nC}$  and  $12\text{nC}$  are separated by a distance of 2m. At what point along the line connecting the two charges is the net electric field due to the two charges equal to zero?
7. Each square centimeter of the surface of an infinite plane sheet of paper has  $4 \times 10^6$  excess electrons. Find the magnitude and direction of the electric field at a point 6.00cm from the surface of the sheet, if the sheet is large enough to be treated as an infinite plane.
8. What is the strength and direction of the electric field 3.74cm on the left hand side of a  $9.1 \text{ nC}$  negative charge?
9. At what distance from a negative charge of  $5.536\text{nC}$  would the electric field strength be  $1.90 \times 10^5\text{N/C}$ ?
10. If it takes 88.3J of work to move 0.721C of charge from a positive plate to a negative plate, what is the potential difference (voltage) between the plates?
11. Two parallel oppositely charged plates are 5.1cm apart. The potential difference, in volts, between the plates is 44.6V. Find the electric field strength between them.
12. Explain Van De Graff generator?
13. What do you mean by a lightening conductor?
14. What is lightening and thunderstorms?
15. What is Electrostatic Shielding?
16. What are Conductors?
17. What will be the electric field intensity due to a group of charges?
18. What are Electric Lines of Force?

# **Electricity**

## Direct Current





# Unit 13

## Arrangement of Resistors in an Electric Circuit

### Key unit competence

At the end of this unit I should be able to describe arrangement of resistors in a simple electric circuit.

### My goals

By the end of this unit, I will be able to:

- Arrange resistors in a simple electric circuit.
- Explain the magnetic effect of an electric current.
- Explain how grounding, fuses, and circuit breakers protect people against electrical shocks and short circuits.
- State and explain the effect of electric current.
- Analyse arrangement of resistors in a simple electric circuit.
- Construct a simple electric circuit with resistors in series and parallel, ammeter and voltmeter.
- Illustrate the effect of electric current.
- Apply knowledge of safety to prevent circuits from overheating devices (fuses and circuit breakers).
- Predict what would happen in a house without a fuse or circuit breakers with overloaded electric circuit.
- Measure electric current and potential difference using an ammeter and voltmeter.

## Key concepts

1. What do you understand by an electric resistor?
2. What is an electric circuit?
3. How to make your own electric circuit.
4. What are materials needed to form a complete simple circuit?
5. Describe different arrangement of resistors in electric circuits.
6. How do you recognise the domestic electric energy use?



## Vocabulary

Simple electric circuit, electric potential, potential difference, electric bell, electromagnet, electrolysis, heat effect, chemical effect.



## Reading strategy

After you have read each section, pay attention to every detail especially the diagrams, illustrations and instructions for every practical work. Perform calculations on electricity and set up your own circuit diagrams.

## 13.1 Simple circuit elements



### Activity 13.1: Making a simple electric circuit

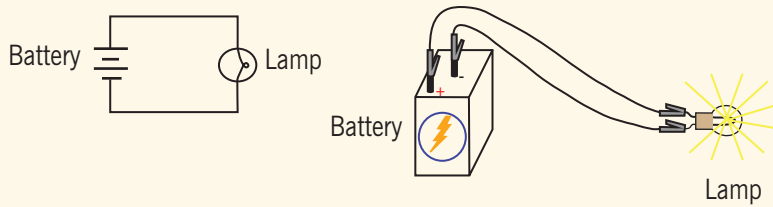
#### Materials:

- 6-volt battery
- 6-volt incandescent lamp
- Jumper wires
- Breadboard
- Terminal strip

With the following given instructions, use provided materials and present your observations.



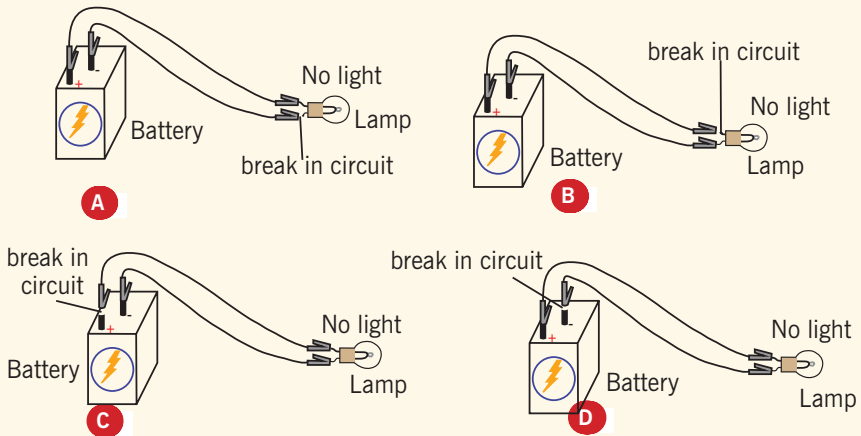
### Schematic diagram and illustration:



**Fig. 13.1:** Diagram and illustration of a simple electric circuit

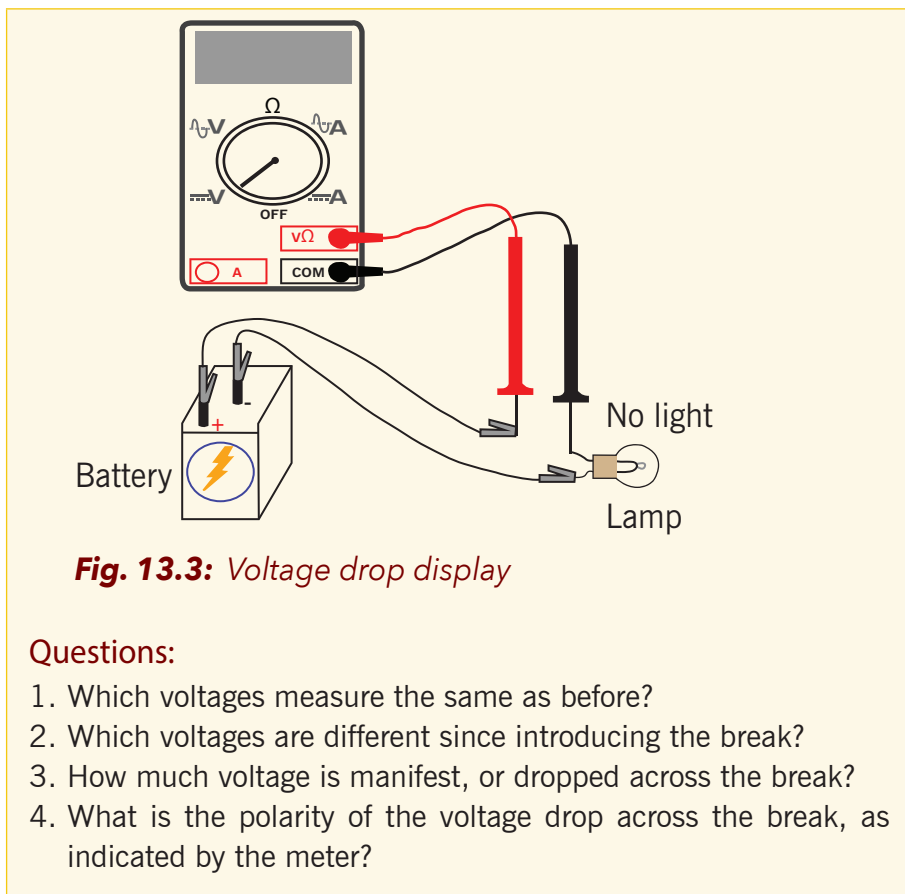
### Instructions:

- Connect the lamp to the battery as shown in the illustration above (Fig. 13.1)
- Connect the lamp as shown in Fig. 13.2 from step (A) to step (D)



**Fig. 13.2:** Illustration of break in electric circuit

- Using your multimeter set to the appropriate “DC volt” range as shown in Fig.13.3 below, measure voltage across the battery, across the lamp, and across each jumper wire. Familiarise yourself with the normal voltages in a functioning circuit.
- Now, “break” the circuit at one point and re-measure voltage between the same sets of points, additionally measuring voltage across the break like this:



**Fig. 13.3:** Voltage drop display

**Questions:**

1. Which voltages measure the same as before?
2. Which voltages are different since introducing the break?
3. How much voltage is manifest, or dropped across the break?
4. What is the polarity of the voltage drop across the break, as indicated by the meter?

Re-connect the jumper wire to the lamp, and break the circuit in another place. Measure all voltage “drops” again, familiarising yourself with the voltages of an “open” circuit.



**Activity 13.2: Using a breadboard in an electric circuit**

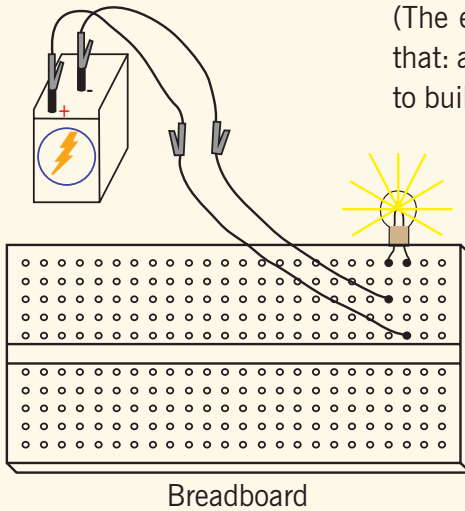
**Materials:** Use the same materials as in activity 13.1

- Essential configuration needed to make a circuit.
- Normal voltage drops in an operating circuit.
- Importance of continuity to a circuit.
- Working definitions of “open” and “short” circuits.
- Breadboard usage.
- Terminal strip usage.

**Procedure:**

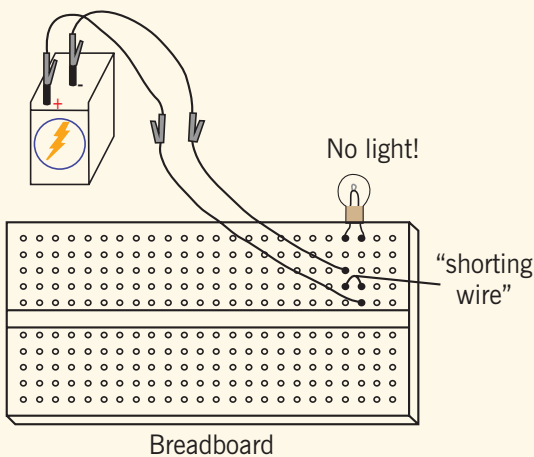
- Construct the same circuit on a breadboard (see Fig.13.4), taking care to place the lamp and wires into the breadboard in such a way that continuity will be maintained.

(The example shown here is only that: an example, not the only way to build a circuit on a breadboard)

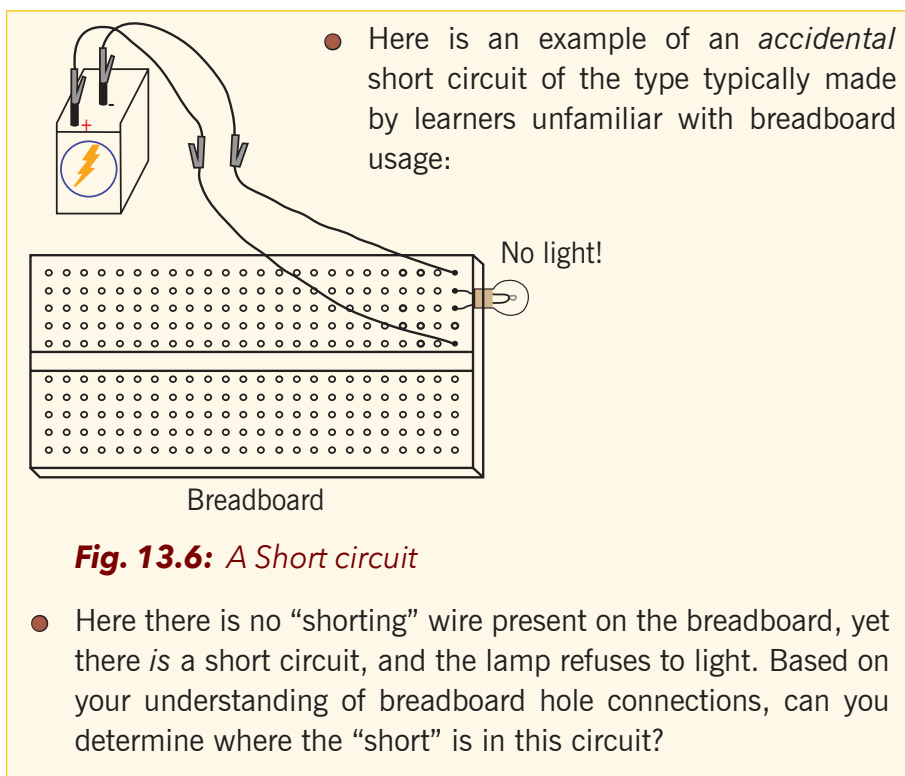


**Fig. 13.4:** *An Electric circuit using a breadboard*

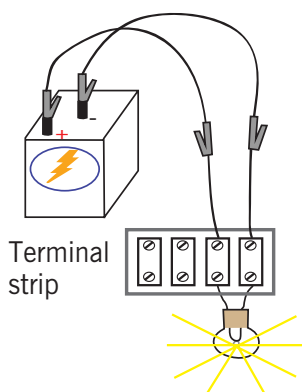
- Experiment with different configurations on the breadboard, plugging the lamp into different holes. If you encounter a situation where the lamp refuses to light up and the connecting wires are getting warm, you probably have a situation known as a short circuit, where a lower-resistance path than the lamp by passes current around the lamp, preventing enough voltage from being dropped across the lamp to light it up. Here is an example of a short circuit made on a breadboard:



**Fig. 13.5:** *Shorting wire on a breadboard*



Short circuits are generally to be avoided, as they result in very high rates of electron flow, causing wires to heat up and battery power sources to deplete. If the power source is substantial enough, a short circuit may cause heat of explosive proportions to manifest, causing equipment damage and hazardous to nearby personnel. This is what happens when a tree limb “shorts” across wires on a power line: the limb being composed of wet wood acts as a low-resistance path to electric current, resulting in heat and sparks.



You may also build the battery/lamp circuit on a terminal strip; a length of insulating material with metal bars and screws to attach wires and component terminals to.

**Fig. 13.7: Terminal Strip**

## 13.2 Arrangement of resistors

### 13.2.1 Series circuits



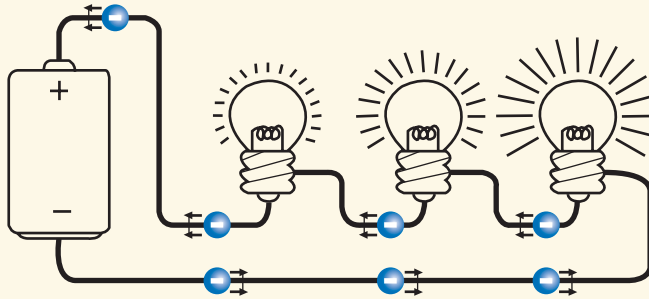
### Activity 13.3: Investigating series connection

#### Materials:

- Battery cells
- Three torch light bulbs
- Conducting wires

#### Procedure:

- Arrange the battery cells as in fig. 13.8 below.
- Connect all the three bulbs in series and switch on.
- Remove one bulb and note your observation.
- Arrange the circuit to have two bulbs, and then one bulb and note your observations.



**Fig. 13.8:** A series circuit

#### Questions:

1. What happens in the circuit with three bulbs when one bulb is removed?
2. What happens when the circuit has two bulbs?
3. What happens when the circuit has one bulb only?

A series circuit is a circuit in which resistors are arranged in a chain, so the current has only one path to take. The current is the same through each resistor. The total resistance of the circuit is found by simply adding up the resistance values of the individual resistors:

**Derivation for effective resistance of resistors in series connection:**

Let the voltage drop (also called the potential difference) measured across  $R_1$  be  $V_1$ ,  $R_2$  be  $V_2$  and for  $R_3$  be  $V_3$

From Ohm's Law, we know that for a circuit with a resistance  $R$  and voltage  $V$ :

$$I = V / R$$

Therefore

$$V = IR$$

So, for resistor  $R_1$ ,  $V_1 = IR_1$ ; for resistor  $R_2$ ,  $V_2 = IR_2$  and for resistor  $R_3$

$$V_3 = IR_3$$

$$V = V_1 + V_2 + V_3$$

Substitute for  $V_1 + V_2$

$$V = IR_1 + IR_2 + IR_3 = I(R_1 + R_2 + R_3)$$

Divide both sides by  $I$

$$V / I = R_1 + R_2 + R_3$$

But from Ohm's Law, we know  $V / I =$  total resistance of the circuit. Let's call it  $R_{total}$

Therefore

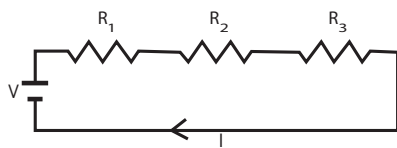
$$R_{total} = R_1 + R_2 + R_3$$

In general if we have  $n$  resistors:

$$R_{total} = R_1 + R_2 + \dots + R_n$$

**Note:**

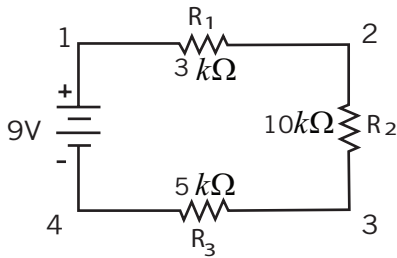
**Resistance** is a measure of the opposition to current flow in an electrical circuit. **Resistance is measured in ohms**, symbolized by the Greek letter omega ( $\Omega$ ). **Ohms** are named after Georg Simon **Ohm** (1784-1854), a German physicist who studied the relationship between voltage, current and **resistance**.



A series circuit is shown in the diagram above. The current flows through each resistor in turn.

**Example:**

Find the equivalent resistance in the circuit below:



$$R = R_1 + R_2 + R_3$$

$$R = 3\text{k}\Omega + 10\text{k}\Omega + 5\text{k}\Omega$$

$$R = 18\text{k}\Omega$$

**13.2.2 Parallel circuits**

### Activity 13.4: Investigating parallel connection

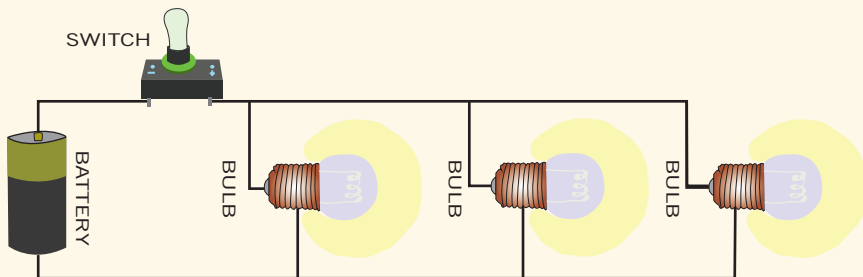
**Materials:**

- Battery cells
- Three torch light bulbs
- Conducting wires

**Procedure:**

- Arrange the battery cells as in fig. 13.9 below.
- Connect all the three bulbs in parallel and switch on.
- Remove one bulb and note your observations.
- Remove the second bulb and note your observations.

PICTORIAL DRAWING OF A PARALLEL CIRCUIT



**Fig. 13.9:** A parallel circuit

**Questions:**

1. What happens in the circuit with three bulbs when one bulb is removed?
2. What happens when the circuit has two bulbs?
3. What happens when the circuit has one bulb only?

The formula of effective resistance in parallel is derived as,

Let the current through resistor  $R_1$  be  $I_1$ , the current through  $R_2$  be  $I_2$  and the current through  $R_3$  be  $I_3$

The voltage drop across both  $R_1$ ,  $R_2$  and  $R_3$  is equal to the supply voltage  $V$ . Therefore, from Ohm's Law

$$I_1 = \frac{V}{R_1}, I_2 = \frac{V}{R_2}, \text{ and } I_3 = \frac{V}{R_3}$$

But we know the current entering a node (connection point) is equal to the current leaving the node (from Kirchhoff's Current Law). Therefore

$$I = I_1 + I_2 + I_3$$

Substituting the values derived for  $I_1$  and  $I_2$  gives us

$$I = \frac{V}{R_1} + \frac{V}{R_2} + \frac{V}{R_3}$$

But  $I = V/R_{\text{total}}$ . Therefore

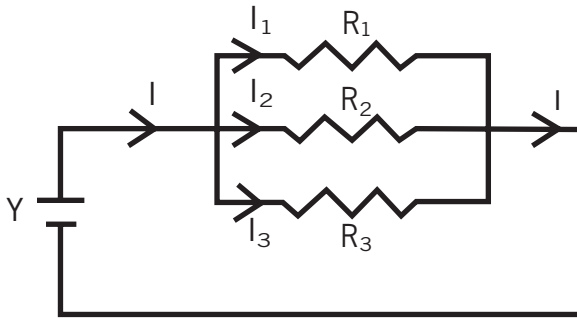
$$\frac{1}{R_{\text{total}}} = \frac{1}{R_1} + \frac{1}{R_2} + \frac{1}{R_3}$$

But if there are two resistors in parallel, the combined resistance is the product of the individual resistances divided by the sum of the resistances. A parallel circuit is a circuit in which the resistors are arranged with their heads connected together, and their tails connected together. The current in a parallel circuit breaks up, with some flowing along each parallel branch and re-combining when the branches meet again. The voltage across each resistor in parallel is the same. The total resistance of a set of resistors in parallel is found by adding up the reciprocals of the resistance values, and then taking the reciprocal of the total.

**NB:**

- There are three paths available for Current. Hence current divides.
- But voltage across the resistors are the same.
- If all the resistors are equal the current will divide equally and the  $R_{\text{Total}}$  will be exactly one third if there are three equal resistors.





A parallel circuit is shown in the diagram above. In this case the current supplied by the battery splits up, and the amount going through each resistor depends on the resistance. If the values of the three resistors are:

$$R_1 = 8 \Omega, R_2 = 8 \Omega \text{ and } R_3 = 4 \Omega$$

The total resistance  $R$  is found by

$$\frac{1}{R} = \frac{1}{8} + \frac{1}{4} + \frac{1}{2} = \frac{5}{8} \Omega$$

$$R = \frac{8}{5} \Omega$$

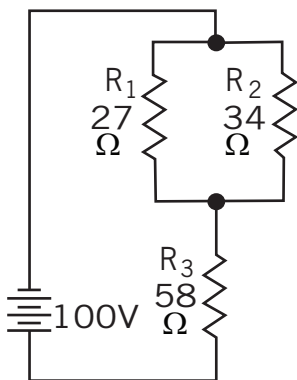
### 13.2.3 Circuits with series and parallel components (In mixture)

If we combined a series circuit with a parallel circuit we produce a Series-Parallel circuit which makes the arrangement of resistors in mixture.

$R_1$  and  $R_2$  are in parallel and  $R_3$  is in series with  $R_1 \parallel R_2$ .

The double lines between  $R_1$  and  $R_2$  are a symbol for parallel.

We need to calculate  $R_1 \parallel R_2$  first before adding  $R_3$ .



Here we can use the shorter product over sum equation as we only have two parallel resistors.

$$\begin{aligned} R_{1 \parallel 2} &= \frac{(R_1 \times R_2)}{(R_1 + R_2)} = \frac{27 \times 34}{27 + 34} \\ &= \frac{918}{61} = 15.049 \Omega \end{aligned}$$

$$\begin{aligned} R_T &= R_{1 \parallel 2} + R_3 = 15.049 \Omega + 58 \Omega \\ &= 73.049 \Omega \end{aligned}$$

Many circuits have a combination of series and parallel resistors. Generally, the total resistance in a circuit like this, is found by reducing

the different series and parallel combinations step-by-step to end up with a single equivalent resistance for the circuit. This allows the current to be determined easily. The current flowing through each resistor can then be found by undoing the reduction process.

General rules for doing the reduction process include:

1. Two (or more) resistors with their heads directly connected together and their tails directly connected together are in parallel, and they can be reduced to one resistor using the equivalent resistance equation for resistors in parallel.
2. Two resistors connected together so that the tail of one is connected to the head of the next, with no other path for the current to take along the line connecting them, are in series and can be reduced to one equivalent resistor.

Finally, remember that for resistors in series, the current is the same for each resistor, and for resistors in parallel, the voltage is the same for each one.

### Checking my progress

1. Three resistors of resistances 2.5, 3.5 and 4.0 ohms are connected in series. What is the effective resistance in such a circuit?
  - (a) 5  $\Omega$
  - (b) 6  $\Omega$
  - (c) 9  $\Omega$
  - (d) 10  $\Omega$
2. The differences between parallel and series connection is;
  - (a) The p.d is always much in series
  - (b) The current is always different in resistors.
  - (c) All resistors in parallel always have the same p.d, but this is not always right for series connection.
  - (d) Resistors in series are always having the same current but this is not necessarily true for parallel connection.
3. When two identical resistors are connected in parallel, the effective resistance is always;
  - (a) Half the sum of the resistors
  - (b) Twice one of the resistors
  - (c) Calculated to know it but you can't mentally know it.
  - (d) Half one of the resistances.

4. Two resistors of resistances  $10\ \Omega$  and  $10\ \text{k}\Omega$ . Which of the two will allow the biggest current to pass through it?

- (a)  $10\ \Omega$
- (b)  $10\ \text{k}\Omega$

### 13.3 Electric potential and electric potential difference



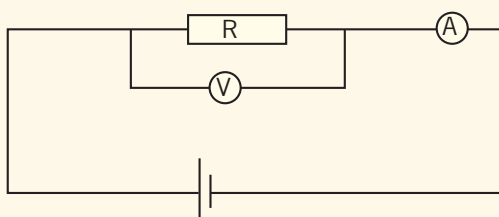
#### Activity 13.5: Investigating electric potential

##### Materials:

- Voltmeter
- Ammeter
- Wire
- Two or three battery cells
- A resistor

##### Procedure:

- Arrange the simple electric circuit, comprising the above materials.
- The Voltmeter should be parallel to the resistor.
- The Ammeter should be in series with the resistor.



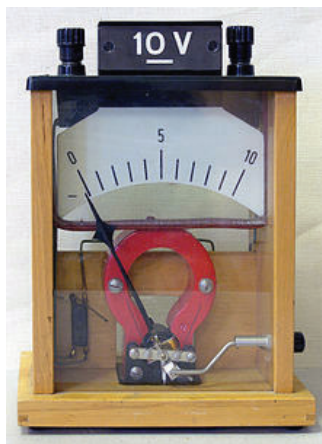
- Use one cell, note and read the value given by the voltmeter.
- Use two cells in series, note and read the value given by the voltmeter.
- Use three cells in series, note and read the value given by the voltmeter.

**Questions:**

1. What do you think the voltmeter is measuring?
2. What is that quantity referred to?
3. Discuss and explain in groups why the number of cells increase as the voltmeter also changes the value.
4. Repeat the procedure given above but arrange cells in parallel then discuss and explain the results obtained.

**Voltage, electric potential difference, electric pressure or electric tension** (formally denoted  $\Delta V$  or  $\Delta U$ , but more often simply as  $V$  or  $U$ , is the difference in electric potential energy between two points per unit electric charge. The voltage between two points is equal to the work done per unit of charge against a static electric field to move the test charge between two points and is measured in units of *volts (V)* (a joule per coulomb).

Voltage can be caused by static electric fields, by electric current through a magnetic field, by time-varying magnetic fields, or some combination of these three.



**Fig. 13.10:** A Voltmeter

A **voltmeter** is used to measure the voltage (or potential difference) between two points in a system; often a common reference potential such as the ground of the system is used as one of the points. A voltage may represent either a source of energy (electromotive force), or lost, used, or stored energy (potential drop).

### Electrical Energy and Electrical Potential

- In order to bring two like charges near each other, **work must be done**.
- In order to separate two opposite charges, **work must be done**.

Remember that whenever work gets done, energy changes form. Electrical potential energy could be measured in Joules just like any other form of energy.

Since the electrical potential energy can change depending on the amount of charge you are moving, it is helpful to describe the electrical potential energy per unit of charge. This is known as electrical potential.

**Note:** This sounds very similar to electrical potential energy, but it is not!

$$\text{Electrical potential} = \frac{\text{Work (or electrical potential energy)}}{\text{unit of charge moved}}$$

As a formula it is written like this:

$$V = \frac{W}{q_{\text{moved}}}$$

The energy per unit of charge is often called voltage so it is symbolised by the capital letter V. Work or energy can be measured in Joules and charge is measured in Coulombs so the electrical potential can be measured in Joules per Coulomb which has been defined as a volt.  $1 \frac{\text{J}}{\text{C}} = 1 \text{ Volt}$

Notice that if we look at the equation again for potential difference but use units of elementary charges (e) and electron volts (eV), we still get units of volts (V) when we are done.

$$V = \frac{W}{q_{\text{moved}}} = \frac{1\text{eV}}{1e} = 1V$$

Remember that:

$$1e = 1.6 \times 10^{-19}\text{C} \text{ this leads us to: } \mathbf{1eV = 1.6 \times 10^{-19}\text{J}}$$

This portion of the unit contains many easy places to develop misunderstandings. They have all been addressed earlier on this page but here is a quick list of them. Please go out of your way to keep these from becoming a misunderstanding for you:

- Electric Potential Energy is **not** the same as Electrical Potential.
- Electrical Potential can also be described by the terms, potential difference, voltage, potential drop, potential rise, electromotive force, and EMF. These terms may differ slightly in meaning depending on the situation.
- The variable we use for potential difference is V and the unit for potential difference is also V (volts). Don't let that confuse you when you see  $V = 1.5V$
- The electron volt is not a smaller unit of the volt, it's a smaller unit of the Joule.

## 13.4 Ohm's law



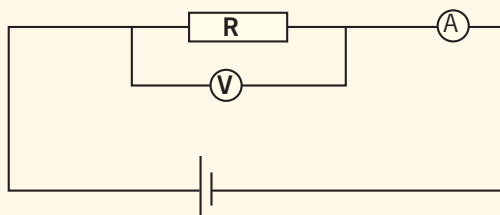
### Activity 13.6: Investigating Ohm's law

#### Materials:

- Voltmeter
- Ammeter
- Wire
- Five battery cells
- A resistor

#### Procedure:

- Arrange the simple electric circuit, comprising the above materials.
- The Voltmeter should be parallel to the resistor.
- The Ammeter should be in series with resistor.



- Use one cell, note and read the value given by the ammeter and voltmeter.
- Use two cells in series, note and read the value given by the voltmeter and the ammeter.
- The Three cells in series then four and then five but each time read and record the different values of current and voltage.
- Record your readings in a table like the one below.

V	I	$\frac{V}{I}$

#### Questions:

1. Discuss and explain in groups why as the number of cells increase, the voltmeter also changes the values and then the reading on the ammeter.
2. Plot a graph of V against I and carefully determine the gradient of the slope of your graph.
3. Compare the value of the gradient of your graph with the values of  $\frac{V}{I}$  in your table. What do you notice?

**Ohm's law** states that the current through a conductor between two points is directly proportional to the voltage across the two points provided temperature and other physical conditions are kept constant. Introducing the constant of proportionality, the resistance, one arrives at the usual mathematical equation that describes this relationship:

$$I = \frac{V}{R}$$

where  $I$  is the current through the conductor in units of amperes,  $V$  is the voltage measured across the conductor in units of volts, and  $R$  is the resistance of the conductor in units of ohms. More specifically, Ohm's law states that the  $R$  in this relation is constant, independent of the current.

The law was named after the German physicist Georg Ohm, who, in a treatise published in 1827, described measurements of applied voltage and current through simple electrical circuits containing various lengths of wire. He presented a slightly more complex equation than the one above (see History section below) to explain his experimental results. The above equation is the modern form of Ohm's law.

### 13.5 Energy and power

Electrical appliances at home transfer energy from the main supply to heat and light our homes as well as to operate our appliances such as TV, Microwave and Computers etc.

The energy used is constant so a TV will use double the amount of energy in two hours as it will in one hour. The power of an electrical appliance tells us how much electrical energy it transfers in a second.

Power,  $P$  is measured in watts (W) where: **1 W = 1 J/s (joule/second)**.

Appliances used for heating have a much higher rating than those used to produce light or sound. The amount of energy transferred from the main appliance depends on the power rating of the appliance and the time for which it is switched on. Energy transferred from electricity is worked out by: Energy = power  $\times$  time

$$E = P \times t$$

Energy,  $E$  is measured in:

- Joules (J) when the power is in watts and the time,  $t$ , is in seconds.
- Kilowatt hours (kWh) when the power is in kilowatts and the time,  $t$ , is in hours.

**Example:** A 800W toaster is switched on for one minute. The energy used is:

$$E = 800 \text{ W} \times 60 \text{ s}$$

$$E = 48000 \text{ J}$$

**Example:** A 1.8 kW kettle used for 5 minutes:

$$E = 1.8 \times \frac{5}{60}$$

$$= 0.15 \text{ kWh}$$

### 13.5.1 Paying for Electricity

The units on an electricity bill, measured by an electricity meter, are kilowatt hours. The cost of each unit of electricity varies. The electricity bill is calculated by working out the number of units used and multiplying by the cost of a unit.

Cost of electrical energy used = power in kW  $\times$  time in hours  $\times$  cost of one unit Or

Cost = number of kWh used  $\times$  cost of one unit

**Example:** The 1kW microwave is used for half an hour and the cost of a unit is 234 Rwf:

$$\text{Cost} = 1\text{kW} \times 0.5 \text{ hours} \times 234 \text{ Rwf/kW h}$$

$$\text{Cost} = 117 \text{ Rwf}$$

### Power, Current and Voltage

The main voltage in the UK is 230V. Electrical power depends on the current and the voltage: Power = current  $\times$  voltage

$$P = I \times V$$

Power is measured in watts (W), current, I, in amps (A) and voltage, V, in volts (V). A torch with a 3.0V battery has a current of 0.4A.

Its power is:  $P = 3.0 \times 0.4 = 1.2\text{W}$



## checking my progress

- Two points A and B in an electric field have potentials of 20V and 120V respectively. What is the potential difference  $V_{AB}$ ?
  - 100V
  - 100V
  - 140V
  - 140V
- Voltmeters are connected in series and ammeters are connected in parallel
  - True
  - False
- The conditions that may make Ohm's law to be invalid are,
  - Changing the length of the wire.
  - Changing the nature of the material of the resistor
  - Applying temperature on the resistor.
  - Adjusting the diameter of the resistor.
- If a 40 watt lamp is turned on for one hour, how many joules of electrical energy have been converted by the lamp?
  - 14,600 joules
  - 14,400 watts
  - 14.400 kJ
  - 14.6kJ

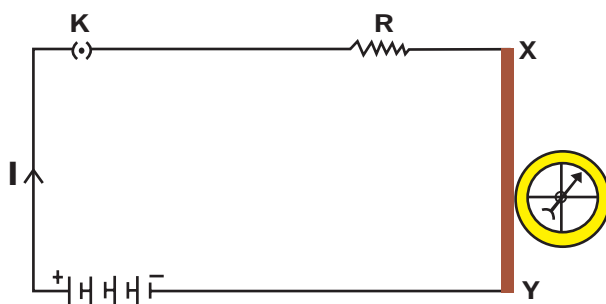
## 13.6 Magnetic effects of electric current

In the previous Chapter on 'Electricity' we learnt about the heating effects of electric current. What could be the other effects of electric current? We know that an electric current-carrying wire behaves like a magnet. Let us perform the following Activity to reinforce it.



### Activity 13.7: Investigation of magnetic effect of electricity

- Take a straight thick copper wire and place it between the points X and Y in an electric circuit, as shown in Fig. 13.11
- Place a small compass near to this copper wire. See the position of its needle.
- Pass the current through the circuit by inserting the key into the plug.
- Observe and discuss the change in the position of the compass needle.



**Fig. 13.11:** The Compass needle is deflected on passing an electric current through a metallic conductor

We see that the needle is deflected. What does it mean? It means that the electric current through the copper wire has produced a magnetic effect. Thus we can say that electricity and magnetism are linked to each other. Then, what about the reverse possibility of an electric effect of moving magnets? In this unit we will study magnetic fields and such electromagnetic effects. We shall also study about electromagnets and electric motors which involve the magnetic effect of electric current, and electric generators which involve the electric effect of moving magnets.

#### Trial activities

- Draw magnetic field lines around a bar magnet.
- List the properties of magnetic lines of force.
- Why don't two magnetic lines of force intersect each other?

We know that the magnetic field produced by a current-carrying wire at a given point depends directly on the current passing through it. Therefore, if there is a circular coil having 'n' turns, the field produced is n times as large as that produced by a single turn. This is because the current in each circular turn has the same direction, and the field due to each turn then just adds up.

## 13.7 The Heating effect of electricity



### Activity 13.8: Investigating the heat effect of an electric current

#### Materials:

- An Electric kettle or electric iron or electric heater.
- Water

#### Procedure:

- Take water in a kettle and connect it on a wall socket. Or,
- Connect the iron on the wall socket, or
- Connect the electric heater and lay it in the bucket of water.

#### Questions:

1. What changes are you observing?
2. Discuss and explain where the heat is coming from.

In our daily life we use many devices where the electrical energy is converted into heat energy, light energy, chemical energy or mechanical energy. When an electric current is passed through a metallic wire like the filament of an electric heater, oven or geyser, the filament gets heated up and here electrical energy is converted into heat energy. This is known as the 'heating effect of current'. Potential difference is a measure of work done in moving a unit charge across a circuit. Current in a circuit is equal to the amount of charge flowing in one second. Therefore, the work done in moving 'Q' charges through a potential difference 'V' in a time 't' is given by: Work done = potential difference x current x time

$$W = V \times I \times t$$

The same can be expressed differently using ohm's law  $V = IR$ .

Therefore work can be expressed as:

$$W = VIt$$

$$\text{or } W = (IR)It = I^2 Rt$$

$$\text{or } W = V \left( \frac{V}{R} \right) t = \frac{V^2}{R} t$$

Thus, heat produced is directly proportional to the resistance, to the time and to the square of the current.

### 13.7.1 Application of the Heating Effect of Current

The heating effect of current is utilised in electrical heating appliances such as the electric iron, room heaters, water heaters, etc. All these heating appliances contain coils of high resistance wire made of nichrome alloy. When these appliances are connected to power supply by insulated copper wires then a large amount of heat is produced in the heating coils because they have high resistance, but a negligible heat is produced in the connecting wires because the wires are made to have low resistance.



**Fig. 13.12:** An Electric fuse and Iron as heat application of current effect

The heating effect of electric current is utilised in electric bulbs for producing light. When electric current passes through a thin high resistance tungsten filament of an electric bulb, the filament becomes white hot and emits light. An 'electric fuse' is an important application of the heating effect of current. When the current drawn in a domestic electric circuit increases beyond a certain value, the fuse wire gets over heated, melts and breaks the circuit. This prevents fire and damage to various electrical appliances.

## 13.8 The Chemical effect of the electric current



### Activity 13.9: Investigating chemical effect of electric current

#### Materials:

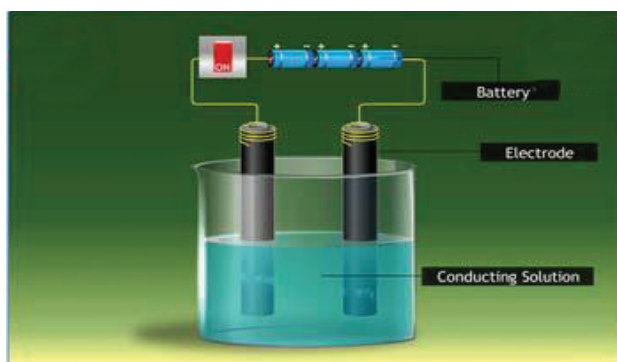
- |                        |                        |
|------------------------|------------------------|
| ● Three battery cells  | ● Water                |
| ● Bulb                 | ● Table salt           |
| ● Switch               | ● Beaker               |
| ● Long conducting wire | ● Two metal electrodes |

**Procedure:**

- Pour water in beaker and mix it with table salt.
- Arrange the circuit as shown in Fig. 13.13
- Switch on and make sure the bulb is lighting (to prove that the current is passing).
- Take like two or three minutes and observe the change on the liquid.

**Questions:**

1. What changes did you observe?
2. Discuss and explain the changes in the liquids.



**Fig. 13.13:** *The Chemical effect of current in electrolysis*

The passage of an electric current through a conducting solution causes chemical reactions. This is known as the chemical effect of electric current. Some of the chemical effects of electric current are the following:

- Formation of bubbles of a gas on the electrodes.
- Deposition of metal on electrodes.
- Change in colour of solutions.

### 13.8.1 Electrolysis

The process of decomposition of a chemical compound in a solution when an electric current passes through it is called **electrolysis**. The solution that conducts electricity due to the presence of ions is called an electrolyte. Two electrodes are inserted in the solution and are connected to the terminals of a battery with a switch in between. This arrangement is called an electrolytic cell. The electrode that is connected to the positive terminal of the battery is called the anode, and the other connected to the negative terminal is called the cathode. The electrolyte contains ions, which are

charged. The positively charged ions are called cations and the negatively charged ions are called anions. Cations, being positively charged, get attracted to the negatively charged cathode and move towards it. On the other hand, anions, being negatively charged, get attracted towards the positively charged anode and move towards it. This is how ions move in an electrolyte and thus conduct electric current. A chemical reaction takes place at the electrodes. The reaction depends on the metals of which the electrodes are made and the electrolyte used. As a result of this reaction, we may observe bubbles at the electrodes due to the production of gases, deposition of metal on the electrodes or change in the colour of the electrolyte.

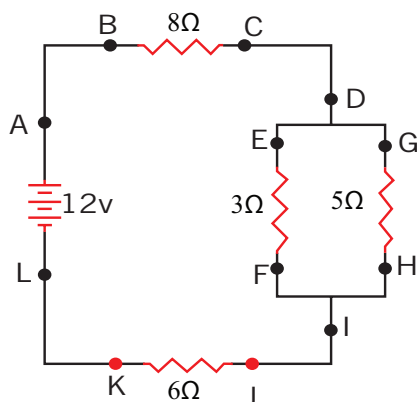
During electrolysis, the concentration of the electrolyte remains unchanged; the number of electrons extracted at the cathode is equal to the number of electrons supplied at the anode; since metal atoms are deposited on the cathode, the mass of the cathode increases and the mass of the anode decreases by an equal amount.

Electrolysis is used in refining and extraction of metals from impure samples. This process is called electro-refining. It is also useful in coating one metal with another. This process is called **electroplating**.

### 13.9 Unit 13 assessment

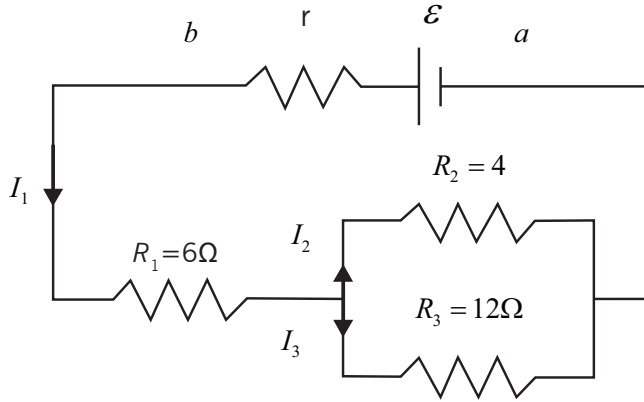
1. Use the diagram above to answer the following questions about electric current.
  - a) The current at location A is \_\_\_\_\_ (greater than, equal to, less than) the current at location B.
  - b) The current at location B is \_\_\_\_\_ (greater than, equal to, less than) the current at location E.
  - c) The current at location G is \_\_\_\_\_ (greater than, equal to, less than) the current at location F.
  - d) The current at location E is \_\_\_\_\_ (greater than, equal to, less than) the current at location G.
  - e) The current at location B is \_\_\_\_\_ (greater than, equal to, less than) the current at location F.
  - f) The current at location A is \_\_\_\_\_ (greater than, equal to, less than) the current at location L.

- g) The current at location H is \_\_\_\_\_ (greater than, equal to, less than) the current at location I.



- h) Use the diagram above to answer the following questions about the electric potential difference. (Assume that the voltage drops in the wires themselves in negligibly small.)
- The electric potential difference (voltage drop) between points B and C is \_\_\_\_\_ (greater than, equal to, less than) the electric potential difference (voltage drop) between points J and K.
  - The electric potential difference (voltage drop) between points B and K is \_\_\_\_\_ (greater than, equal to, less than) the electric potential difference (voltage drop) between points D and I.
  - The electric potential difference (voltage drop) between points E and F is \_\_\_\_\_ (greater than, equal to, less than) the electric potential difference (voltage drop) between points G and H.
  - The electric potential difference (voltage drop) between points E and F is \_\_\_\_\_ (greater than, equal to, less than) the electric potential difference (voltage drop) between points D and I.
  - The electric potential difference (voltage drop) between points J and K is \_\_\_\_\_ (greater than, equal to, less than) the electric potential difference (voltage drop) between points D and I.
  - The electric potential difference between points L and A is \_\_\_\_\_ (greater than, equal to, less than) the electric potential difference (voltage drop) between points B and K.
2. A battery whose emf is 20V and internal resistance of  $1\Omega$  is connected to three resistors according to the diagram in the Figure below. Determine:
- the potential difference to the battery terminals;

- b) the current through each resistor and voltages across each resistor;
- c) the power supplied by the emf;
- d) the power dissipated in each resistor.



3. Use the concept of equivalent resistance to determine the unknown resistance of the identified resistor that would make the circuit's equivalent.

Diagram A

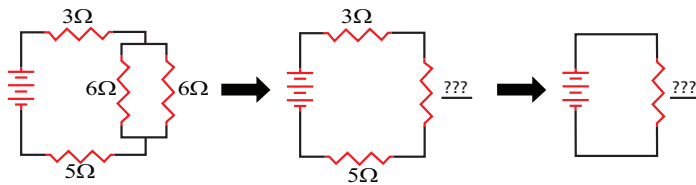


Diagram B

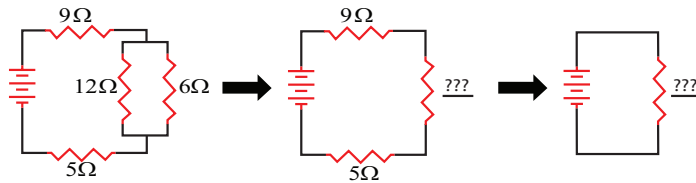
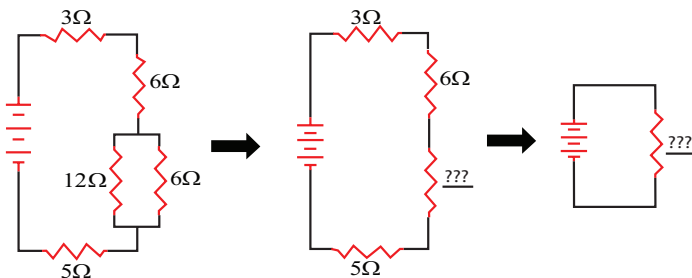
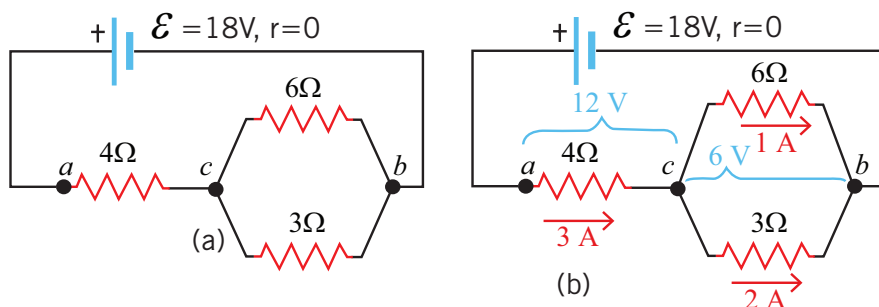


Diagram C

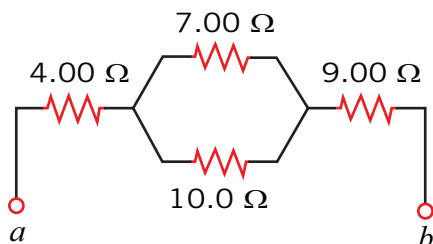




4. A parallel pair of resistance of value of  $3\Omega$  and  $6\Omega$  are together connected in series with another resistor of value  $4\Omega$  and a battery of e.m.f.  $18\text{ V}$  as shown on the fig. (a) below. Calculate the current through each resistor.

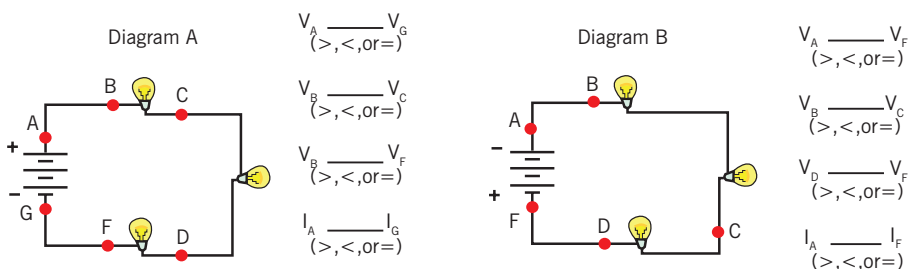


5. (a) Find the equivalent resistance between points  $a$  and  $b$  in the figure below.  
 (b) A potential difference of  $34.0\text{ V}$  is applied between points  $a$  and  $b$ . Calculate the current in each resistor.

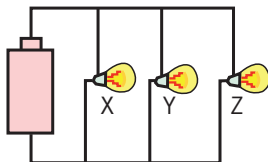


6. Use your understanding of equivalent resistance to complete the following statements:
- Two  $3\Omega$  resistors placed in series would provide a resistance which is equivalent to one  $\_\_\_\Omega$  resistor.
  - Three  $3\Omega$  resistors placed in series would provide a resistance which is equivalent to one  $\_\_\_\Omega$  resistor.
  - Three  $5\Omega$  resistors placed in series would provide a resistance which is equivalent to one  $\_\_\_\Omega$  resistor.
  - Three resistors with resistance values of  $2\Omega$ ,  $4\Omega$  and  $6\Omega$  are placed in series. These would provide a resistance which is equivalent to one  $\_\_\_\Omega$  resistor.
  - Three resistors with resistance values of  $5\Omega$ ,  $6\Omega$  and  $7\Omega$  are placed in series. These would provide a resistance which is equivalent to one  $\_\_\_\_\_\Omega$  resistor.

- f) Three resistors with resistance values of  $12\Omega$ ,  $3\Omega$  and  $21\Omega$  are placed in series. These would provide a resistance which is equivalent to one \_\_\_\_\_  $\Omega$  resistor.
7. As the number of resistors in a series circuit increases, the overall resistance \_\_\_\_\_ (increases, decreases, remains the same) and the current in the circuit \_\_\_\_\_ (increases, decreases, remains the same).
8. Consider the following two diagrams of series circuits. For each diagram, use arrows to indicate the direction of the conventional current. Then, make comparisons of the voltage and the current at the designated points for each diagram.



9. As more and more resistors are added in parallel to a circuit, the equivalent resistance of the circuit \_\_\_\_\_ (increases, decreases) and the total current of the circuit \_\_\_\_\_ (increases, decreases).
10. Which adjustments could be made to the circuit below that would decrease the current in the cell? List all that apply.



- Increase the resistance of bulb X.
- Decrease the resistance of bulb X.
- Increase the resistance of bulb Z.
- Decrease the resistance of bulb Z.
- Increase the voltage of the cell (somehow).
- Decrease the voltage of the cell (somehow).
- Remove bulb Y.

---

**Light**

Reflection

---





# Unit 14

## Reflection of light in curved mirrors

### Key unit competence

---

By the end of this unit I should be able to analyse the applications of reflected light.

### My goals

---

By the end of this unit, I will be able to:

- Identify reflection of light in plane mirrors.
- State the laws of reflection of light in plane mirrors.
- Explain the terms used in curved mirrors.
- Describe the formation of images by spherical mirrors.
- List the applications of spherical mirrors.
- Establish the images formed by curved mirrors.
- Locate by construction images formed in curved mirrors and state their characteristics.
- Perform an experiment to determine the focal length of spherical mirrors.
- Evaluate images formed by curved mirrors.
- Discuss applications of curved mirrors.
- Solve problems related to curved mirrors.
- Recognise and describe the applications of reflection of light in curved mirrors.
- List the applications of plane-curved mirrors.

## Key concepts

1. How do you draw an image formed by a plane mirror?
2. What do you understand by the term spherical/ curved mirror?
3. How to make a ray diagram of an image formed by a curved mirror.
4. Describe the characteristics of an image formed by a curved mirror.
5. What are different applications of curved mirrors in real life?



## Vocabulary

Concave mirror, convex mirror, radius of curvature, focal length, pole, aperture, principal axis, centre of curvature, real and virtual image.



## Reading strategy

As you read this section, pay attention to key words/terms. Align them with diagrams and compare them with real life mirror objects you see in the community. Perform calculations related to the spherical mirror as well as making drawings.

## 14.1 Recall reflection of light in plane mirrors



### Activity 14.1: Bouncing back of light by the mirror

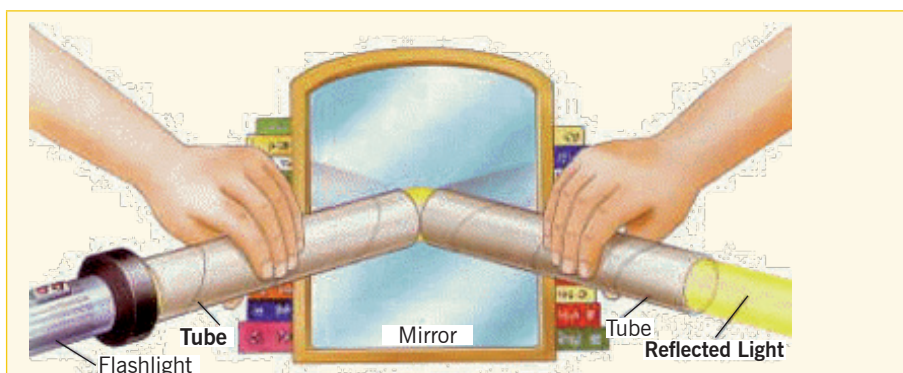
When light hits a smooth surface, it always bounces back at a matching angle. To see how this works, try this test. (Fig.14.1)

#### Materials:

- a large plane mirror,
- two cardboard tubes,
- a flashlight,
- some objects.

#### Procedure:

1. Use some objects like a book, bricks etc to prop the mirror upright.
2. Hold one tube at an angle with the end touching the mirror.
3. Ask a friend to hold the second tube at a matching angle.
4. Shine the flashlight into the tube you are holding.



**Fig. 14.1:** Reflection of light with a mirror

### Questions:

1. Explain and discuss your observations.
2. Where are mirrors useful?

## 14.1.1 Plane Mirrors

Mirrors are smooth reflecting surfaces, usually made of polished metal or glass that has been coated with a metallic substance. As you know, even an uncoated material can act as a mirror, however, when one side of a piece of glass is coated with a compound such as tin or silver, its reflectivity is increased and light is not transmitted through the coating. A mirror may be front coated or back coated depending on the application. A mirror with a flat surface is called a **plane mirror**.

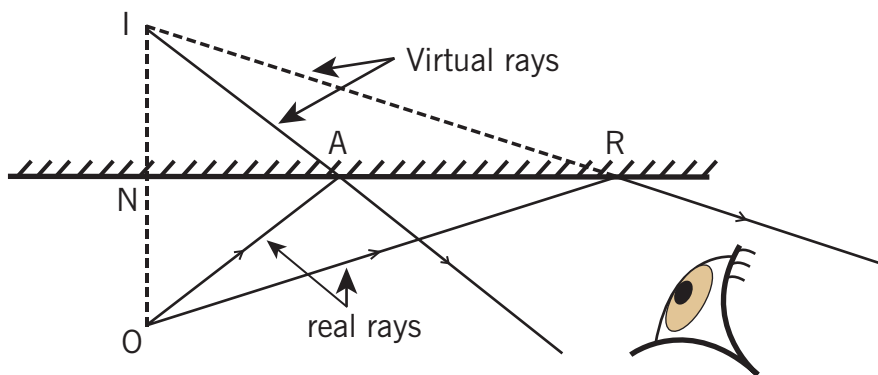
## 14.1.2 Images Formed in Plane Mirrors

When we view an object directly, light comes to our eyes straight from the object. When we view an object with an optical system, our eyes perceive light that seems to come straight from the object but whose path has actually been altered. As a result we see an image that may be different in size, orientation or apparent position from the actual object.

In some cases, light actually comes from the image to our eyes; the image is then called a **real image**. In other cases light only appears to come from the image location; the image is then called a **virtual image**.

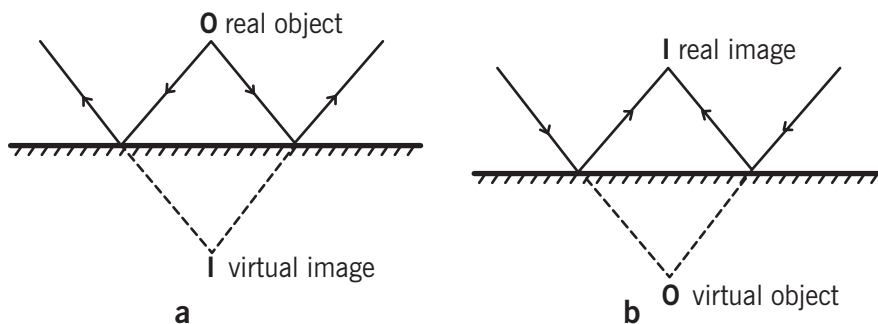
**Note:** A real image is one which can be produced on a screen while a virtual image cannot be formed on a screen.

Rays from the object at O are reflected according to the Laws of reflection so that they appear to come from point I behind the mirror and this is where the observer imagines the image to be. The image at I is called a virtual image because the rays of light do not actually pass through it, they only seem to come from it.



**Fig. 14.2:** Formation of an image on a plane mirror

It is possible for a plane mirror to give a real image. In Fig. 14.3 below, a converging beam is reflected so that the reflected rays actually pass through a point I in front of the mirror. There is a real image at I which can be picked up on a screen. At the point O, towards which the incident beam was converging before it was intercepted by the mirror, there is considered to be a **virtual object**.



**Fig. 14.3:** (a) Shows that converging beams from a big object give a virtual point object O and a real Image I. (b) Shows that a divergent beam from a real point object gives a virtual point image.

The distance of an object from a mirror is called the **object distance** ( $d_o$ ) and the distance the image appears to be behind the mirror is called the **image distance** ( $d_i$ ). By geometry of similar triangles it can be shown that  $d_o = d_i$ . Therefore the image formed by a plane mirror appears to be at a distance behind the mirror that is equal to the distance of the object in front of the mirror. In other words, object and image are equidistant from the mirror.



## 14.2 Curved mirrors



### Activity 14.2: Reflection in spherical mirror

#### Materials:

- Concave mirror (s)
- Convex mirror (s)
- An object like a candle

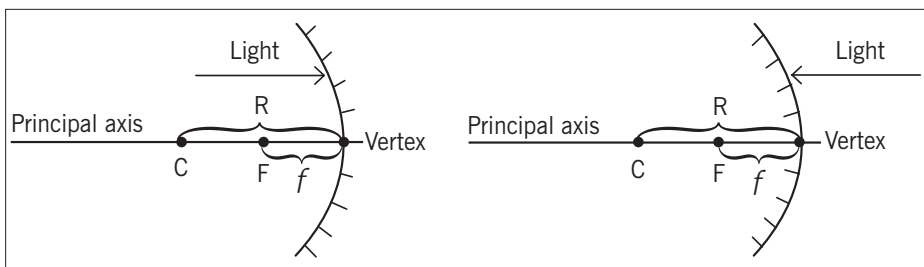
#### Procedures:

- Observe the images of your objects (candle) using given mirrors.
- Move the candle near by the mirror or far from the mirror and observe the changes on its images.

#### Questions:

1. What happens to the image of the candle as it moves near to the curved mirror?
2. What happens to the image of the candle as it moves far from the curved mirror?
3. Discuss other cases where you observe such situations.

We shall consider specifically curved mirrors which have a spherical shape. Such mirrors are called spherical mirrors. Depending on the side coated, front or back, the two types of spherical mirrors are concave and convex,



**Fig. 14.4:** Concave Mirror and Convex Mirror

Spherical mirrors can be thought of as a portion of a sphere which was sliced and then coated on one side to create a reflective surface. Concave mirrors are coated on the outside of the sphere while convex mirrors are coated on the inside of the sphere.

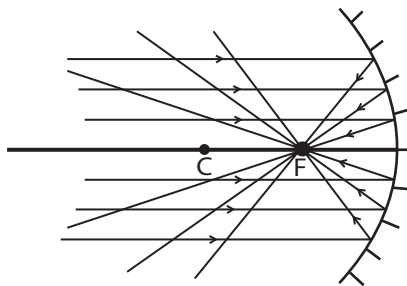
### 14.2.1 Terms and Definitions

- **Centre of curvature (C)** is the point in the centre of the sphere from which the mirror was sliced. For concave mirrors, the centre C, of the sphere is in front of the reflecting surface. For a convex mirror, C is behind the reflecting surface.
- **Vertex** is the point on the mirror surface where the principal axis meets the mirror. The vertex is also known as the **pole**. The vertex is the geometric center of the mirror.
- **Focal point (F)** is the point midway between the vertex and centre of curvature. It is also called the “principal focus”.
- **Radius of curvature (R)** is the distance between the centre of the curvature and the vertex. It is the radius of the sphere from which the mirror was cut.
- **Focal length (f)** is the distance from the mirror to the focal point.
- **Aperture** is the surface of the mirror.

Since the focal point (F) is the mid-point of the line segment joining the vertex and the centre of curvature, the focal length ( $f$ ) would be half the radius of curvature.

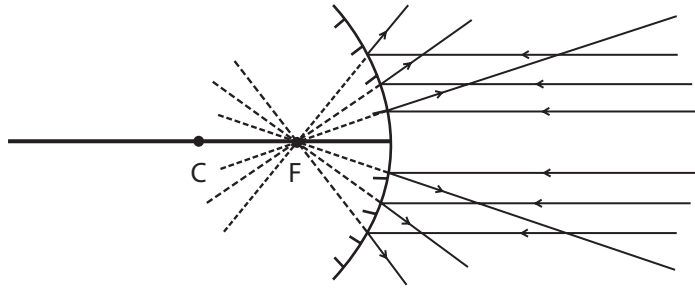
$$i.e. f = \frac{R}{2} \text{ or } R = 2f$$

A narrow beam of rays parallel and near the principal axis is reflected from a concave mirror so that all rays converge on the focal point. Concave mirrors are also known as converging mirrors because of their action on the parallel beams of light.



**Fig. 14.5:** Rays parallel to the principal axis of the concave mirror

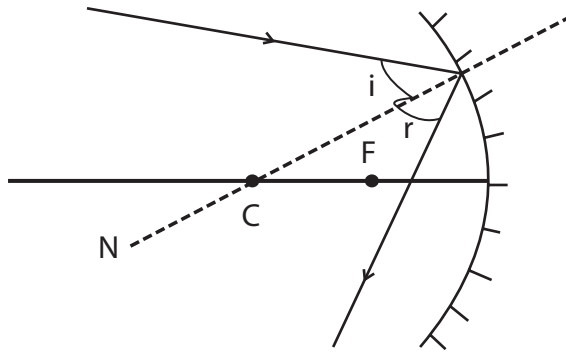
A narrow beam of parallel light rays near the principal axis of a convex mirror are reflected to form a diverging beam which appears to come from the focal point (F) behind the mirror.



**Fig. 14.6:** Rays parallel to the principal axis of a convex mirror

### 14.2.2 Reflection of Light and Image Formation

Light always follows the laws of reflection, whether reflection occurs off a curved surface or flat surface. For a spherical mirror, the normal at the point of incidence on the mirror surface is a line that extends through the centre of curvature. Once the normal is drawn, the angle of incidence can be measured and the reflected ray can be drawn with the same angle.



**Fig. 14.7:** Ray non-parallel to the principal axis of the curved mirror

In general the position of the image formed by spherical mirror and its nature, i.e. whether it is real, virtual (imaginary), inverted, upright, magnified or diminished (reduced), depends on the distance of the object from the mirror. Information about the image can be obtained by either drawing a ray diagram or by calculating using a formula.

### 14.2.3 Ray Diagrams



#### Activity 14.3: Investigating the ray diagram of an image

**Materials:**

- Concave mirror(s)
- Convex mirror(s)
- Candle(s)
- Lens holder
- White cardboard (screen).

**Procedure:**

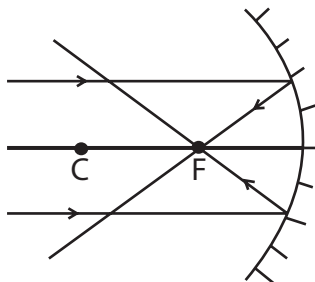
- Fix the concave or the convex mirror in a lens holder.
- Put the lighted candle and distance X (infront of the reflecting surface of the mirror).
- On the same side, put the screen in different positions until you get an image.

**Questions:**

1. Try to note your observations discuss and explain them.
2. What is the nature of the image obtained?
3. Comment and explain where the concave and convex mirrors are used in real life.

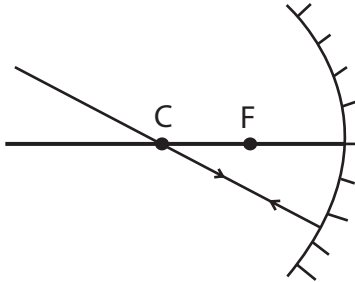
We shall assume that a small object on the principal axis of mirrors of a small aperture are being considered and that all rays are paraxial (i.e. nearly parallel to the axis). Point images will therefore be formed of points on the object. To construct the image, two of the following three rays are drawn from the top of the object:

1. A ray parallel to the principal axis which after reflection actually passes through the focal point or appears to diverge from the focal point.



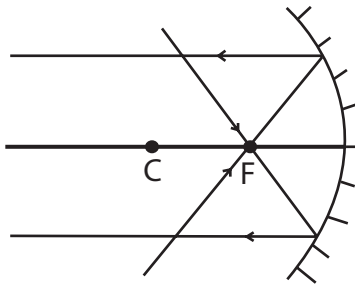
**Fig. 14.8:** Rays reflecting through the main focus

2. A ray through the centre of the curvature which strikes the mirror normally and is reflected along the same path.



**Fig. 14.9:** Rays passing through the center of curvature

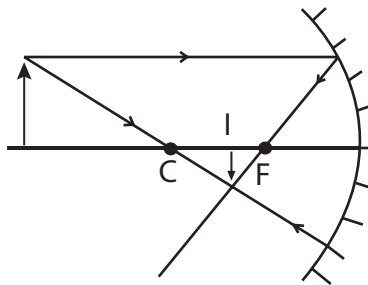
3. A ray through the principal axis at the focal point which is reflected parallel to the principal axis, i.e. a ray taking the reverse path of (1).



**Fig. 14.10:** Rays passing through the main focus

#### 14.2.4 Image characteristics of Concave Mirrors

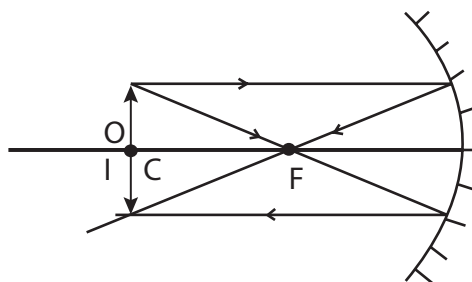
Case 1: The object (O) is located beyond the centre of curvature



**Fig. 14.11:** Image of an object placed beyond C

The image (I) is located between C and F, it is real, inverted and diminished.

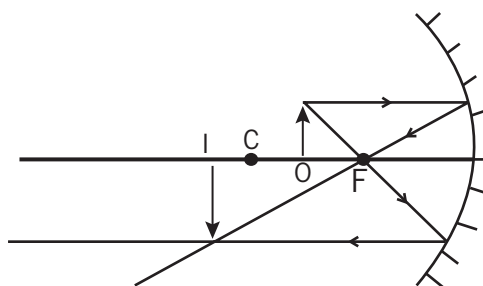
### Case 2: The object (O) is located at the centre of curvature



**Fig. 14.12:** Object placed at C

The image (I) is located at C, it is real, inverted and the same size.

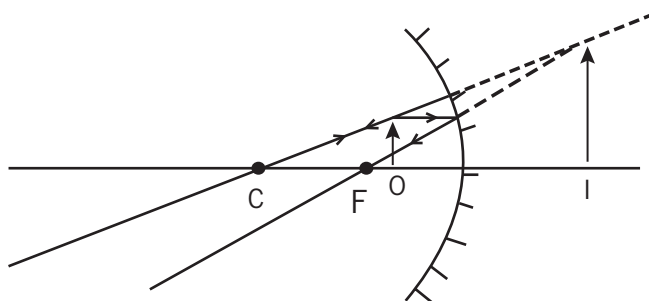
### Case 3: The object (O) is located between C and F.



**Fig. 14.13:** Image of an object placed between C and F

The image (I) is located beyond C, it is real, inverted and magnified.

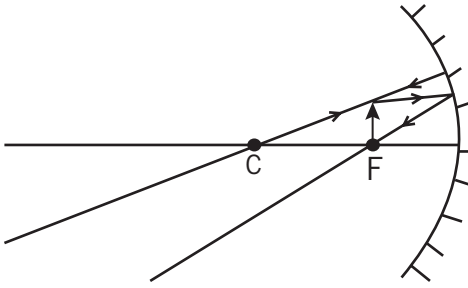
### Case 4: The object (O) is located between the focal point and vertex.



**Fig. 14.14:** Image given by a convex mirror

The image (I) is located behind the mirror, it is virtual, upright and magnified.

### Case 5: The object (O) is located at the focal point.



**Fig. 14.15:** Image of an object placed at F is found at infinity

The image is located at infinity because the reflected rays are parallel.

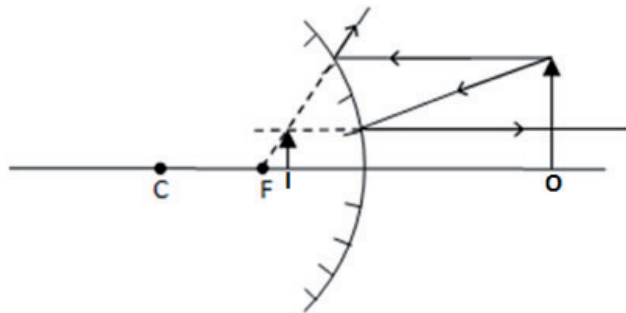
#### Notes:

- (i) In cases 1 and 3, the object and image are interchangeable. Such positions are called conjugate points.
- (ii) C is a self conjugate as case 2 shows the object and image are both at C.
- (iii) An object at infinity, i.e. a long way off, forms a real image at F. Conversely an object at F gives an image at infinity.
- (iv) In all cases the foot of the object is on the principal axis and its image also is on the principal axis.

### 14.2.5 Image characteristics for Convex Mirrors

Consider different positions of the object (O):

The image (I) for the convex mirror is always located between F and the vertex, it is virtual, upright and diminished.



**Fig. 14.16:** Image characteristic for a convex mirror

## 14.3 Uses of spherical mirrors

Concave mirrors are used as reflectors in car headlamps and search lights and are essential components of large telescopes. Convex mirrors give a wider field of view than a plane mirror. Therefore, they are used as car wing mirrors, for safety on sharp bends in the road, for security in shops and on the stairs of double-decker buses. Convex mirrors make the estimation of distances more difficult because large movements of the object result in small movement of the image.

## 14.4 The mirror and magnification equations

Ray diagrams can be used to determine the image location, size, orientation and type of image formed of objects placed at a given location in front of concave and convex mirrors. Ray diagrams provide useful information about the object/image relationships, but do not provide quantitative solutions. To obtain quantitative information it is necessary to use the mirror equation and the magnification equation.

The mirror equation expresses the quantitative relationship between object distance ( $d_o$ ), image distance ( $d_i$ ), and the focal length ( $f$ ). The **mirror equation** is:

$$\frac{1}{f} = \frac{1}{d_o} + \frac{1}{d_i}$$

Since  $R = 2f$ , the mirror equation can be re-written in terms of the radius of the curvature ( $R$ ):

$$\frac{2}{R} = \frac{1}{d_o} + \frac{1}{d_i}$$

The mirror equation can also be re-written as:

$$d_i = \frac{d_o f}{d_o - f}$$

The **magnification equation** relates the ratio of image distance to object distance and the ratio of image height to object height.

$$m = -\frac{d_i}{d_o} = \frac{h_i}{h_o}$$

The minus sign is inserted for a sign convention to indicate orientation of the image.



**Example:**

1. An object is placed at a distance of 15cm from a concave mirror of focal length 10cm. Find the nature of the image formed and size.

**Solution:**

$$d_o = 15\text{cm}$$

$$d_i = ?$$

$$f = 10\text{cm}$$

Using

$$\frac{1}{f} = \frac{1}{d_o} + \frac{1}{d_i}$$

$$\frac{1}{10} = \frac{1}{15} + \frac{1}{d_i} \Rightarrow d_i = +30\text{cm}$$

The positive image distance means that the image is real.

To know the size, we calculate the magnification.

$$m = -\frac{d_i}{d_o} = -\frac{30}{15} = -2$$

The negative sign means that the image is inverted and  $m = 2$  means that the image is two times bigger than the object.

2. A convex mirror forms an image at a distance of 2.5cm of an object at a distance of 5.0cm. Calculate the focal length of this mirror and the properties of the image formed.

**Solution:**

$$d_o = 5.0\text{cm}$$

$$d_i = -2.5\text{cm} \text{ (negative means a virtual image)}$$

$$f = ?$$

Using

$$\frac{1}{f} = \frac{1}{d_o} + \frac{1}{d_i}$$

$$\frac{1}{f} = \frac{1}{5.0} + \frac{1}{-2.5} \Rightarrow f = -5.0\text{cm}$$

(Negative means a convex mirror)

**Properties of the image:**

The image formed by a convex mirror is always virtual, diminished and upright.

Concave Mirror	Convex Mirror	$d_i$	$m$	$M$
$f$ is positive ( $f$ )	$f$ is negative ( $-f$ )	(+) real image	(+) upright	$m > 1$ image magnified
		(-) virtual image	(-) inverted	$m < 1$ image diminished

Notes:

- (i) A real image is on the same side of the mirror as the object.
- (ii) A virtual image is on the opposite side of the mirror from object.
- (iii) When determining whether an image is magnified or diminished do not consider the sign of the magnification. The sign is only used to determine whether the image is upright or inverted (i.e.  $m = -3$  and  $m = 3$  both mean the image is magnified 3 times but  $m = -3$  means the image is inverted ( $-m$ ) and  $m = 3$  means the image is upright ( $+m$ ).



**Activity 14.4: To measure the focal length of a concave mirror**

Make a practical activity related to the Fig. 14.17. The Teacher may assist you to set up such a system.)

**Materials:**

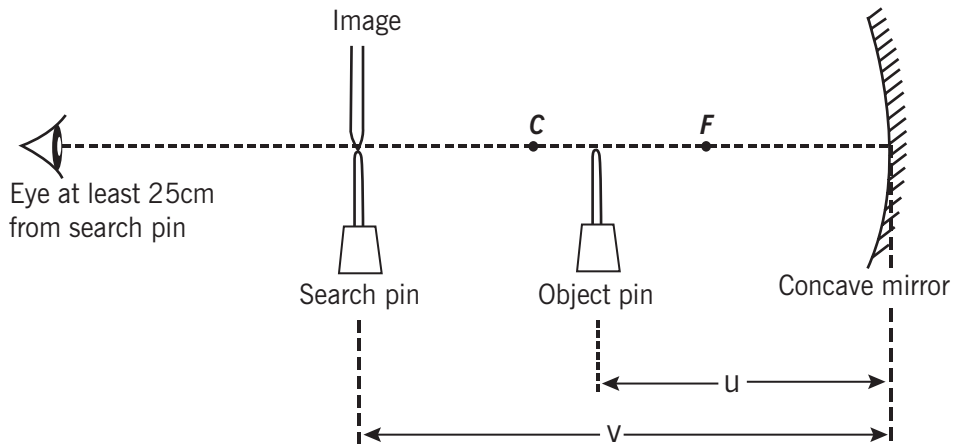
- Concave mirror
- Optical pin (2)

**Learning Outcomes:**

I should understand the following terms:

- Concave mirror
- Focal point
- Radius of curvature

Sometimes the image is a little difficult to find, but this can usually be overcome by making quite sure that the principal axis of the mirror passes through the tip of the object pin. In experiments of this type, one must resist a natural inclination to look into the mirror. The eye should be fixed on the pin, and the image will be seen to move backwards and forwards as the pin is moved to and fro. The pin is halted just when the image is exactly above it. Hence, if  $d_o$  and  $d_i$  are measured, we can calculate  $f$  two pins are required, one to act as an object and the other as a search pin. The object pin is placed in front of the mirror between  $F$  and  $C$  so that a magnified real image is formed beyond  $C$ . The search pin is then placed so that there is no parallax between it and the real image (Fig. 14.17).



**Fig. 14.17:** The  $U$  and  $V$  methods



### Activity 14.5: To find the focal length of a convex mirror using a convex mirror

Make a practical activity related to the Fig. 14.18; The teacher may assist you to set up such a system.

#### Materials:

- Convex mirror
- Optical pin

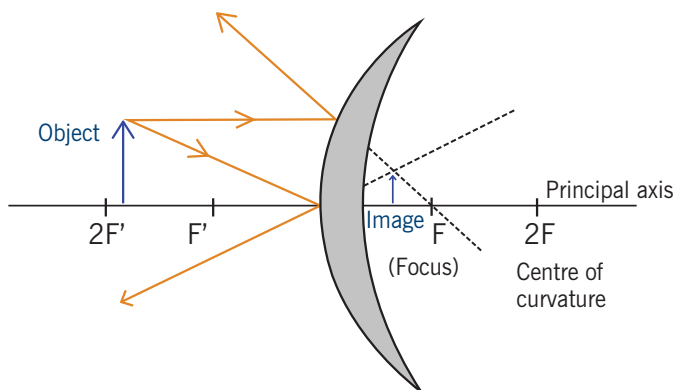
#### Learning Outcomes:

I should understand the following terms:

- Convex mirror
- Focal point
- Radius of curvature

A convex mirror is a curved mirror in which the reflecting surface bulges towards the light source. Convex mirrors reflect light outwards; therefore they are not used to focus light. A convex mirror is also known as a fish eye mirror or diverging mirror.

The image formed by a convex lens is virtual and erect, since the focal point ( $F$ ) and the centre of curvature ( $2F$ ) are both imaginary points "inside" the mirror that cannot be reached. As a result, images formed by these mirrors cannot be projected on a screen, since the image is inside the mirror. Therefore, its focal length cannot be determined directly. The image is smaller than the object, but gets larger as the object approaches the mirror. The ray diagram of a convex mirror is shown below.



**Fig. 14.18:** Measuring the focal length of a convex mirror

The focal length  $f$  of the convex mirror is calculated using the formula,

$$f = \frac{\text{Radius of curvature}}{2} = \frac{R}{2}$$

### Checking my progress

1. Real images are formed by .....intersection of light rays whereas virtual images are formed by .....intersection of light rays.

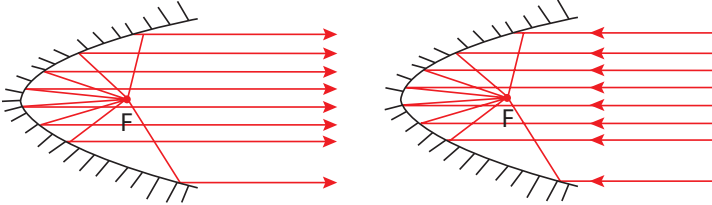
Fill in choosing from these words. (apparent, focal, actual, prolonged)

2. The following are characteristics of images formed by a plane mirror except.
  - (a) Magnified.
  - (b) Same size as the object.
  - (c) Virtual
  - (d) Laterally inverted.
  - (e) Blurred
3. The difference between curved mirrors and plane mirrors is;
  - (a) Curved form magnified images, but plane do not.
  - (b) Plane mirrors are not used in cars, but planes are used there.
  - (c) Plane mirrors are categorized into convex and concave, but curved mirrors are not.
4. The focal length of the convex mirror is always negative (virtual)
  - (a) True
  - (b) False
5. Calculate the focal length of a concave mirror which forms a real image at a distance of 70.0cm, for an object at 17.5cm.
  - (a) 1.4cm
  - (b) 28m
  - (c) 17.5cm
  - (d) 0.14m.

## 14.5 Other types of curved mirrors

### 14.5.1 Parabolic mirrors

A **parabolic mirror (or parabolic reflector)** has a reflective surface used to collect or project light. Its shape is that of a circular paraboloid, that is, the surface generated by a parabola revolving around its axis.



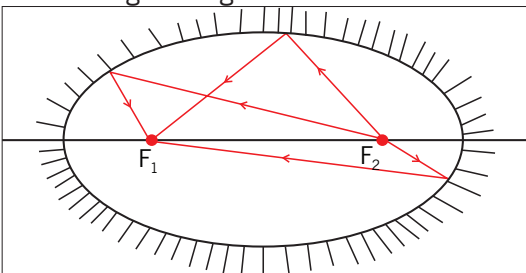
**Fig. 14.19:** Parabolic mirrors

Any incoming ray that is parallel to the axis of the dish will be reflected to the focal point, or “focus”. Because light can be reflected in this way, parabolic reflectors can be used to collect and concentrate light entering the reflector at a particular angle. Similarly, light radiating from the “focus” to the dish can be transmitted outward in a beam that is parallel to the axis of the dish. In contrast with spherical reflectors, which suffer from a spherical aberration, the parabolic reflectors can be made to accommodate beams of any width. However, if the incoming beam makes a non-zero angle with the axis (or if the emitting point source is not placed in the focus), parabolic reflectors suffer from an aberration called coma.

The most common modern applications of the parabolic reflector are in satellite dishes, reflecting telescopes, and many lighting devices such as spotlights, car headlights etc.

### 14.5.2 The Ellipsoidal mirror

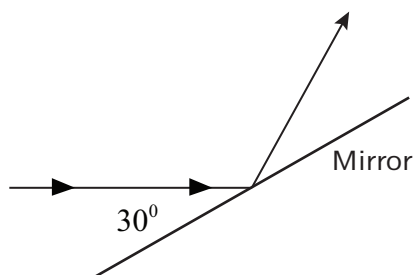
Ellipsoidal mirrors have two conjugate foci (but in this case the focus is a geometric point commonly for any ellipsoid). Light from one focus passes through the other focus after reflection. Ellipsoids collect a much higher fraction of total emitted light than a spherical mirror or conventional lens system. The ellipsoidal mirror is the most efficient optics element of introducing the light that there was from one point into another point.



**Fig. 14.20:** The Ellipsoidal mirror

## 14.6 Unit 14 assessment

1. Consider the diagram at the right. Which one of the angles (A, B, C, or D) is the angle of incidence? \_\_\_\_\_ which one of the angles is the angle of reflection? \_\_\_\_\_

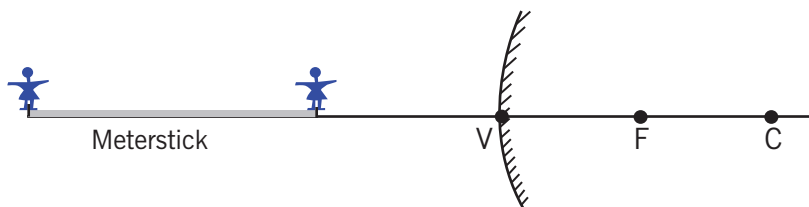


2. A ray of light is incident towards a plane mirror at an angle of  $30^\circ$  with the mirror surface. What will be the angle of reflection?
3. A ray of light is approaching a set of three mirrors as shown in the diagram. The light ray is approaching the first mirror at an angle of  $45^\circ$  with the mirror surface. Trace the path of the light ray as it bounces off the mirror. Continue tracing the ray until it finally exits from the mirror system. How many times will the ray reflect before it finally exits?



4. Draw a ray diagram to show that a vertical mirror need not be 1.60m long in order that a woman 1.60m tall may see a full-length image of herself in it. If the man's eyes are 10cm below the top of her head, find the shortest length of the mirror necessary and the length of its base above floor level.
5. A concave spherical mirror has a focal length of 10.0cm. Locate the image of a pencil that is placed upright 30.0cm from the mirror.
- Find the magnification of the image.
  - Draw a ray diagram to confirm your answer.
6. An upright pencil is placed 10.0cm from a convex spherical mirror with a focal length of 8.00cm. Find the position and the magnification of the image.

7. An object is placed (a) 20cm, (b) 4cm, in front of a concave mirror of focal length 12cm. Find the nature and the position of the image formed in each case.
8. A concave mirror produces a real image 1cm tall of an object 2.5mm tall placed 5cm from the mirror. Find the position of the image and the focal length of the mirror.
9. A convex mirror of focal length 18cm produces an image on its axis, 6cm away from the mirror. Calculate the position of the object.
10. A 1.5cm high diamond ring is placed 20.0cm from a concave mirror whose radius of curvature is 30.0cm. Determine:
  - a) The position of the image, and its size.
  - b) Where the new image will be if the object is placed where the image is.
11. An object of height  $h = 4\text{cm}$  is placed a distance  $p = 15\text{cm}$  in front of a concave mirror of focal length  $f = 20\text{cm}$ .
  - a) What is the height, location, and nature of the image?
  - b) Suppose that the object is moved to a new position a distance  $p = 25\text{cm}$  in front of the mirror. What now is the height, location, and nature of the image?
12. A dental technician uses a small mirror that gives a magnification of 4.0 when it is held 0.60cm from a tooth. What is the radius of the curvature of the mirror?
13. A meter stick lies along the optical axis of a convex mirror of focal length 40cm, with its near end 60cm from the mirror surface. Five-centimeter toy figures stand erect on both the near and far ends of the meter stick.




- a) How long is the virtual image of the meter stick?
  - b) How tall are the toy figures in the image, and are they erect or inverted?
14. How far must an object be placed in front of a convex mirror of radius of curvature  $R = 50\text{cm}$  in order to ensure that the size of the image is ten times less than the size of the object? How far behind the mirror is the image located?

# **Electronics**

Electronic Devices





# Unit 15

## Basic Electronic Components

### Key unit competence

---

By the end of this unit I should be able to explain the working principle of basic electronic devices.

### My goals

---

By the end of this unit, I will be able to:

- Define an electronic device.
- Identify symbols of electronic components.
- Name different electronic components.
- Outline the working principle of basic electronic devices.
- Mention the importance of electronic devices in everyday life.
- Appreciate the important role of electronic devices in life.
- Demonstrate knowledge in analysing and modeling physical processes.

### Key concepts

---

1. What do you understand by the term electronic?
2. How can you differentiate electronics from electricity?
3. Illustrate different electronic components.
4. What is a motherboard?
5. Describe different examples of electronic devices.



### Vocabulary

---

Electronics, motherboard, forwarding bias, reverse bias, transistor, diode, capacitor, inductor, electronic devices.



## Reading strategy

After you read each section, pay attention to the paragraphs that contain definitions of key terms. Use all the information to explain the key terms in your own words and make drawings of different electronic components and their functions and suggest different applications on motherboards.

### 15.1 Definition of electronics



#### Activity 15.1: Investigation about what electronics is.

Take a dictionary and discuss on the following key concepts.

- Electronics
- Conductors
- Electricity
- Semi-conductors

#### Questions:

1. Give the difference between electricity and electronics.
2. Give the difference between conductors and semi-conductors.
3. When listening to the radio, where do you think voices are coming from?
4. When watching a television where do you think images are coming from and how are they coming on your television set?

**Electronics** is the branch of science that deals with the study of **flow and control of electrons** (electricity) and the study of their behaviour and effects in **vacuums, gases, and semi-conductors**, and with devices using such electrons. This control of electrons is accomplished by devices that **resist, carry, select, steer, switch, store, manipulate, and exploit the electron**.

**In fact, Electronics** is the branch of physics that deals with the emission and effects of electrons and with the use of electronic devices. Electronics refers to the flow of charge (moving electrons) through non-metal conductors; mainly semi-conductors, whereas **electrical** refers to the flow of charge through metal conductors. The Difference between Electronics and Electrical is that: Electronics deals with flow of charge (electron) through non-metal conductors (semi-conductors) while Electrical deals with the flow of charge through metal conductors.

**Semi-conductor devices:** This is a conductor made of semi-conducting material. Semi-conductors are made up of a substance with electrical properties intermediate between a good conductor and a good insulator. A semi-conductor device conducts electricity poorly at room temperature, but has increasing conductivity at higher temperatures. Metalloids are usually good semi-conductors.

**Example:** Flow of charge through silicon which is not a metal would come under electronics whereas flow of charge through copper which is a metal would come under electrical.

## 15.2 Illustration of standard symbols of some electronic components



### Activity 15.2: Identifying the electronic devices

Use the provided devices in Figures 15.1 and 15.2 to answer the following questions.



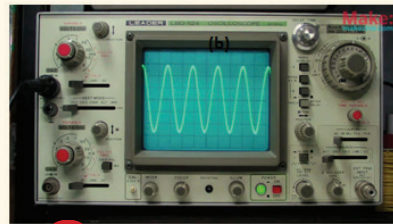
a)



b)

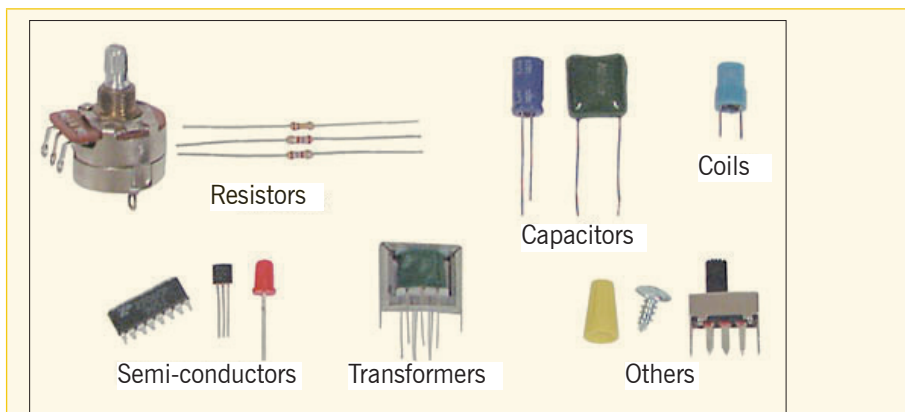


c)



d)

**Fig. 15.1:** Some electronic devices



**Fig. 15.2:** Electronic components

**Questions:**

1. Discuss and write the names of the electronic devices in Fig. 15.1.
2. Discuss the function of each component in Fig. 15.2.
3. Why are devices in Fig. 15.1 recognised to be electronic devices?

Electronic components are basic electronic elements or electronic parts usually packaged in a discrete form with two or more connecting leads or metallic pads. Electronic components are intended to be connected together, usually by soldering to a printed circuit board (PCB), to create an electronic circuit with a particular function (for example an amplifier, radio receiver, computer, oscillator) (see Fig 15.1). Some of the main Electronic components are: resistors, capacitors, semi-conductors (transistor, diode, operational amplifier, etc) transformers and others (See Fig. 15.2).

Electronic Components are of 2 types: Passive and Active



**Activity 15.3: Identification of electronic components**

Search the internet or use a dictionary plus the provided electronic components in table 15.1 to define and depict the function of each component and then answer the following questions.

**Materials:**

Motherboard of an electronic device (such as a radio receiver)

**Questions:**


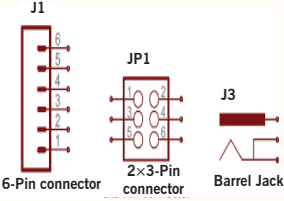

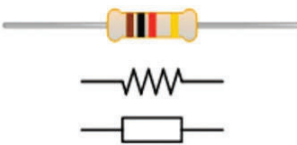

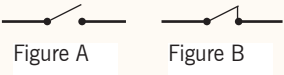


1. Identify and list down the components that are on the motherboard.
2. Draw their symbols and comment on them.
3. Write down in two columns, which ones are passive and which ones are active electronic devices.
4. Take any motherboard to find and identify its electronic components.



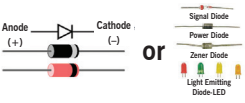
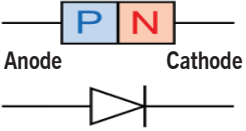


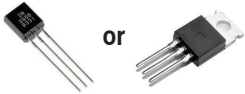
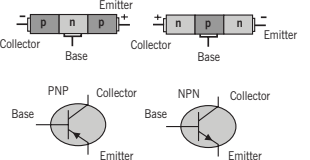

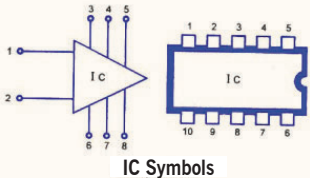
**Passive electronic components** are those that do not have gain or directionality. They are also called Electrical elements or electrical components. E.g. resistors, capacitors, diodes, inductors.

**Active electronic components** are those that have gain or directionality. E.g. transistors.

Here are some of the Electronic Components and their functions in electronics and electrical (Table 15.1 below):

**Table 15.1:** Electronic component

Name	Image	Symbol	Functions
1. Terminals and Connectors		 <p>J1 6-Pin connector</p> <p>JP1 2x3-Pin connector</p> <p>J3 Barrel Jack</p>	Components to make an electrical connection.
2. Resistors			Components used to resist current.
3. Switches		 <p>Figure A</p> <p>Figure B</p>	Components that may be made to either conduct (closed) or not (open).
4. Capacitors			Components that store electrical charge in an electrical field.

Name	Image	Symbol	Functions
<p>5. <b>Magnetic or Inductive Components</b></p>	 <p>INDUCTOR cylindrical</p>		<p>These are Electrical components that use magnetism</p>
<p>6. <b>Ordinary Diodes</b></p>			<p>Components that conduct electricity in only one direction.</p>
<p>7. <b>Zener diode</b></p>			<p>A <b>Zener diode</b> allows current to flow from its anode to its cathode like a normal semi-conductor diode, but it also permits current to flow in the reverse direction when its “Zener voltage” is reached.</p>
<p>8. <b>Transistors</b></p>			<p>A semi-conductor device capable of amplification</p>
<p>9. <b>Integrated Circuits or ICs: A</b></p>			<p>A Microelectronic computer circuit incorporated into a chip or semi-conductor; a whole system rather than a single component.</p>

### 15.2.1 Electronic component name acronyms

**Electronic Component Name Acronyms:** Here is a list of Electronic Component name abbreviations widely used in the electronics industry:

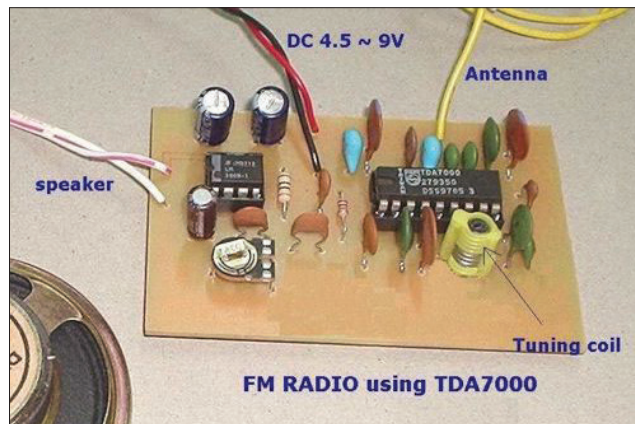
<ul style="list-style-type: none"> <li>▪ <b>AE:</b> Aerial, antenna</li> <li>▪ <b>B:</b> Battery</li> <li>▪ <b>BR:</b> Bridge rectifier</li> <li>▪ <b>C:</b> Capacitor</li> <li>▪ <b>CRT:</b> Cathode ray tube</li> </ul>	<ul style="list-style-type: none"> <li>▪ <b>LCD:</b> Liquid crystal display</li> <li>▪ <b>LDR:</b> Light dependent resistor</li> <li>▪ <b>LED:</b> Light emitting diode</li> <li>▪ <b>LS:</b> Speaker</li> <li>▪ <b>M:</b> Motor</li> <li>▪ <b>MCB:</b> Circuit breaker</li> </ul>
<ul style="list-style-type: none"> <li>▪ <b>D or CR:</b> Diode</li> <li>▪ <b>F:</b> Fuse</li> <li>▪ <b>GDT:</b> Gas discharge tube</li> <li>▪ <b>IC:</b> Integrated circuit</li> <li>▪ <b>J:</b> Wire link</li> </ul>	<ul style="list-style-type: none"> <li>▪ <b>Mic:</b> Microphone</li> <li>▪ <b>Ne:</b> Neon lamp</li> <li>▪ <b>OP:</b> Operational Amplifier</li> <li>▪ <b>JFET:</b> Junction gate field-effect transistor</li> <li>▪ <b>L:</b> Inductor</li> </ul>

### 15.3 Electronic components on a motherboard



#### Activity 15.4: Identifying electronic components on a motherboard

Take the mother board of a radio receiver and try to identify the different electronic components in Fig. 15.3.



**Fig. 15.3:** Motherboard

Alternatively referred to as the **mb**, **mainboard**, **mobo**, **mobd**, **backplane board**, **base board**, **main circuit board**, **planar board**, **system board**, or a **logic board** on Apple computers, the **motherboard** is a printed circuit board that is the foundation of any electronic device. For a computer, it is located at the bottom of the computer case. It allocates power to the CPU, RAM, and all other computer hardware components. Most importantly, the motherboard allows hardware components to communicate with one another.



### 15.3.1 Ordinary diode



#### Activity 15.5: Different types of diodes

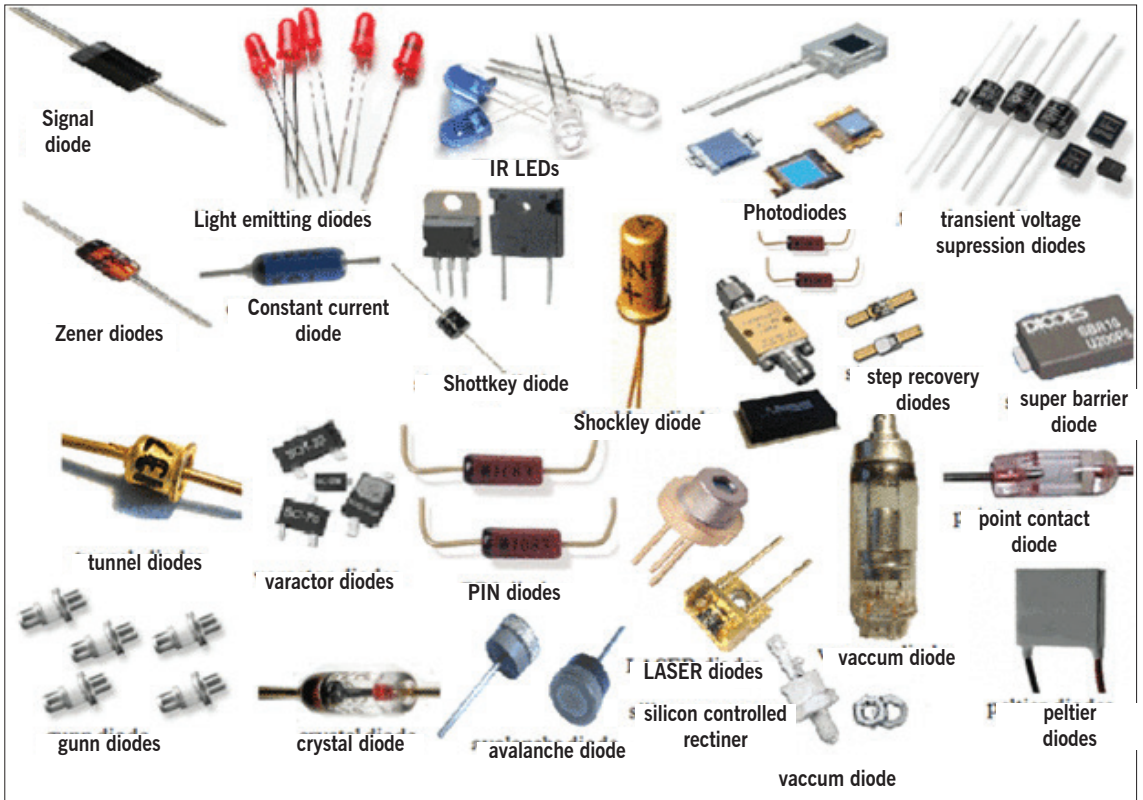
Using a dictionary and the internet, plus the provided diodes in Fig 15.4, define and depict the function of each type of diode and answer the following questions.

**Materials:**

Motherboard of an electronic device (such as a computer).

**Questions:**

1. Write down the application of each type of diode.
2. Take any motherboard to find and identify different types of diodes on it.



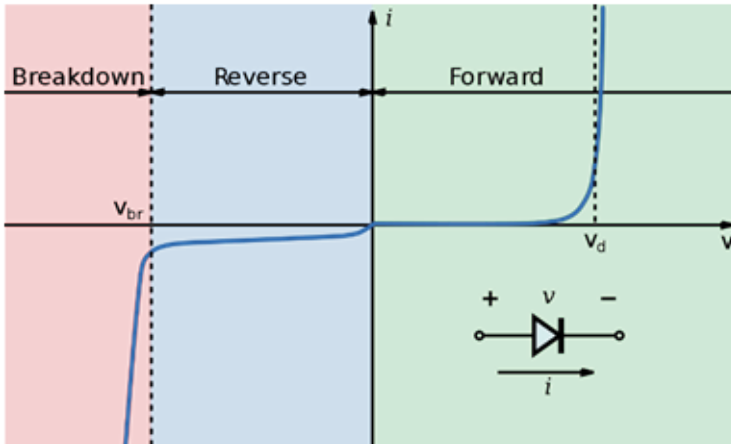
**Fig. 15.4:** Types of diodes

In electronics, a **diode** is a two-terminal electronic component that conducts primarily in one direction (asymmetric conductance); it has low (ideally zero) resistance to the flow of current in one direction, and high



(ideally infinite) resistance in the other. A **semi-conductor diode**, the most common type today, is a crystalline piece of semi-conductor material with a p–n junction connected to two electrical terminals. A vacuum tube diode has two electrodes, a plate (anode) and a heated cathode. Semi-conductor diodes were the first semi-conductor electronic devices.

## 15.4 Current–voltage characteristic



**Fig. 15.5:** *I-V (current vs. voltage) characteristics of a p-n junction diode*

A semi-conductor diode's behaviour in a circuit is given by its current–voltage characteristic, or I–V graph (Fig. 15.5). The shape of the curve is determined by the transport of charge carriers through the so-called *depletion layer* or *depletion region* that exists at the p–n junction between differing semi-conductors. When a p–n junction is first created, conduction-band (mobile) electrons from the N-doped region diffuse into the P-doped region where there is a large population of holes (vacant places for electrons) with which the electrons “recombine”.

### 15.4.1 Forwarding and reverse biasing

If an external voltage is placed across the diode with the same polarity as the built-in potential, the depletion zone continues to act as an insulator, preventing any significant electric current flow (unless electron–hole pairs are actively being created in the junction by, for instance, light (LEDs); this is called the **reverse bias** phenomenon. However, if the polarity of the external voltage opposes the built-in potential, recombination can once again proceed, resulting in a substantial electric current through the p–n junction (i.e. substantial numbers of electrons and holes recombine at the junction). Thus, if an external voltage greater than and opposite to the built-in voltage is applied, a current will flow and the diode is said to be “turned on” as it has been given an external **forward bias**. The diode is commonly said to have a forward “**threshold**” voltage, above which it conducts and below which conduction stops. However, this is only an approximation as the forward characteristic is according to the Shockley equation absolutely smooth (see Fig. 15.6)

### 15.4.2 Rectifications



#### Activity 15.6: Defining rectifier

Use a dictionary and search the internet to identify the meaning of rectifier and its function.

#### Materials

A telephone charger

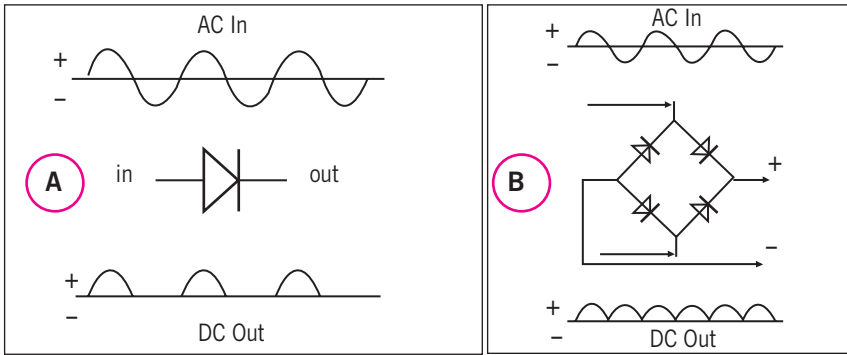
An AC to DC converter

#### Procedure:

Open the charger and identify the component of the motherboard inside it.

#### Question:

1. When charging a phone why does it require a specific charger plug?
2. Describe and explain different components found on that motherboard.
3. Discuss and comment on the importance of rectifiers.

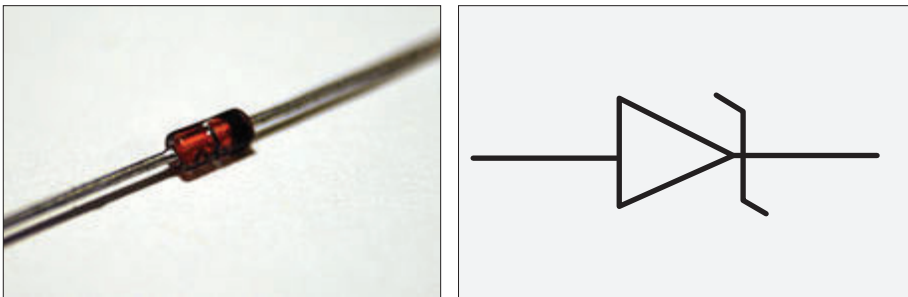


**Fig. 15.6:** Half wave rectifier and full wave rectifier

The non-symmetric behaviour is due to the detailed properties of the p-n junction. The diode acts like a one-way valve for current and this is a very useful characteristic. One application is to convert alternating current (AC), which changes polarity periodically, into direct current (DC), which always has the same polarity. Normal household power is AC while batteries provide DC; and converting from AC to DC is called rectification. Diodes are used so commonly for this purpose that they are sometimes called **rectifiers**, although there are other types of rectifying devices. Fig. 15.6 (a) shows the input and output current for a simple half-wave rectifier. The circuit gets its name from the fact that the output is just the positive half of the input waveform.

Fig. 15.6 (b) shows a full-wave rectifier circuit which uses four diodes arranged so that both polarities of the input waveform can be used at the output. The full-wave circuit is more efficient than the half-wave one.

### 15.4.3 Zener Diode

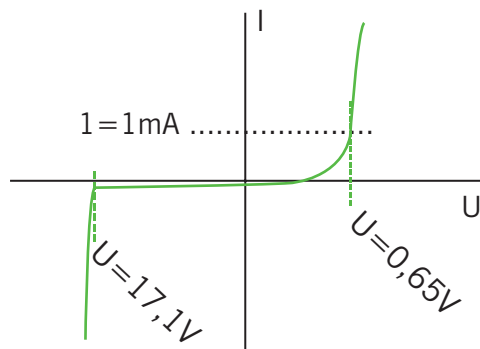


**Fig. 15.7:** Zener diode and its symbol

A **Zener diode (Fig. 15.7)** allows current to flow from its anode to its cathode like a normal semi-conductor diode, but it also permits current to flow in the reverse direction when its “Zener voltage” is reached. Zener diodes have a highly doped, p-n junction. Normal diodes will also break down with a reverse voltage but the voltage and sharpness of the knee are not as well defined as for a Zener diode. Also normal diodes are not designed to operate in the breakdown region, but Zener diodes can reliably operate in this region.

### Operation (voltage regulator)

Consider the current-voltage characteristic of a Zener diode with a breakdown voltage of 17 volts. Notice the change of voltage scale between the forward biased (positive) direction and the reverse biased (negative) direction, as shown in the Fig. 15.8 below.



**Fig. 15.8:** *I-V curve for Zener diode*

A conventional solid-state diode allows significant current if it is reverse-biased above its reverse breakdown voltage. When the reverse bias breakdown voltage is exceeded, a conventional diode is subject to high current due to avalanche breakdown. Unless this current is limited by circuitry, the diode may be permanently damaged due to overheating. A Zener diode exhibits almost the same properties, except the device is specially designed so as to have a reduced breakdown voltage, the so-called Zener voltage. By contrast with the conventional device, a reverse-biased Zener diode exhibits a controlled breakdown and allows the current to keep the voltage across the Zener diode close to the Zener **breakdown voltage**. For example, a diode with a Zener breakdown voltage of 3.2V exhibits a voltage drop of nearly 3.2V across a wide range of reverse currents. The Zener diode is therefore ideal for applications such as the generation of a reference voltage (e.g. for an amplifier stage), or as a voltage stabilizer for low-current applications.

## 15.4.6 Transistors



### Activity 15.7: Identifying a transistor

#### Materials

Motherboard of a radio receiver

#### Procedure:

Identify transistors from the motherboard among many electronic components on it.

#### Question:

1. According to its position, try to discern its function there.
2. Where else in other components is a transistor useful?
3. Comment and discuss the further use of a transistor.

A **transistor** is a semi-conductor device used to amplify or switch electronic signals and electrical power. It is composed of semi-conductor material with at least three terminals for connection to an external circuit. A voltage or current applied to one pair of the transistor's terminals changes the current through another pair of terminals. Because the controlled (output) power can be higher than the controlling (input) power, a transistor can amplify a signal. Today, some transistors are packaged individually, but many more are found embedded in integrated circuits.

#### Simplified operation

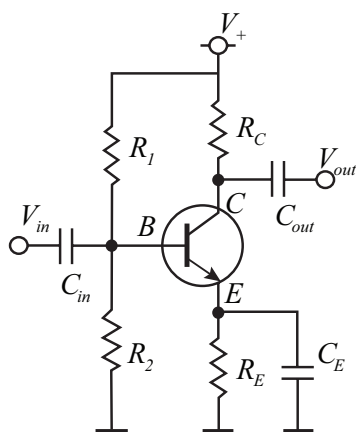
The essential usefulness of a transistor comes from its ability to use a small signal applied between one pair of its terminals to control a much larger signal at another pair of terminals. This property is called **gain**. It can produce a stronger output signal, a voltage or current, which is proportional to a weaker input signal; that is, it can act as an amplifier. Alternatively, the transistor can be used to turn current on or off in a circuit as an electrically controlled switch, where the amount of current is determined by other circuit elements.

There are two types of transistors, which have slight differences in how they are used in a circuit. A *bipolar transistor* has terminals labeled **base**, **collector**, and **emitter**.

A small current at the base terminal (that is, flowing between the base and the emitter) can control or switch a much larger current between the

collector and emitter terminals. For a *field-effect transistor*, the terminals are labeled **gate**, **source**, and **drain**, and a voltage at the gate can control a current between source and drain.

### Transistor as an amplifier



The common-emitter amplifier is designed so that a small change in voltage ( $V_{in}$ ) changes the small current through the base of the transistor; the transistor's current amplification combined with the properties of the circuit mean that small swings in  $V_{in}$  produce large changes in  $V_{out}$ .

Various configurations of a single transistor amplifier are possible, with some providing current gain, some voltage gain, and some both.

**Fig. 15.9:** Amplifier circuit, common-emitter configuration with a voltage-divider bias circuit

Modern transistor audio amplifiers of up to a few hundred watts are common and relatively inexpensive.

### Checking my progress

1. The examples of semi-conductors include the following except.
  - (a) Germanium
  - (b) Silicon
  - (c) Arsenic
  - (d) Zinc
2. Computers and radios are all semi-conductor devices.
  - (a) True
  - (b) False
3. Active devices control current flowing in the circuit, but passive devices do not control current flowing in the circuit.
  - (a) True
  - (b) False
4. The examples of passive devices are the following except.
  - (a) Battery
  - (b) Transistor
  - (c) Inductor
  - (d) Capacitor
  - (e) SCR

## 15.5 An example of electronic devices



### Activity 15.8: Visiting an Electronic repair workshop

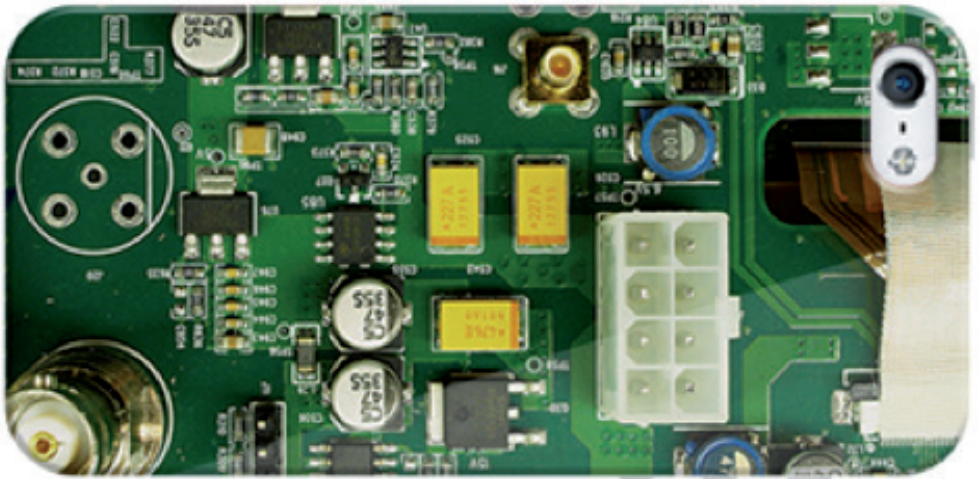
Use any available computer or phone visit a computer or phone repair workshops to identify different components of a telephone and computer.

#### Question:

Discuss and explain the components such as diodes, resistors, capacitors, transistors and the function of:

1. A telephone.
2. A computer.
3. A radio receiver.

### 15.6.1 Mobile phone



**Fig. 15.10:** Mobile phone motherboard

All mobile phones have a number of features in common, but manufacturers also try to differentiate their own products by implementing additional functions to make them more attractive to consumers. This has led to great innovation in mobile phone development over the past 20 years.

## 15.5.2 Computers

The motherboard is the main component of a computer. It is a large rectangular board with integrated circuitry that connects the other parts of the computer including the CPU, the RAM, the disk drives (CD, DVD, hard disk, or any others) as well as any peripherals connected via the ports or the expansion slots.

Components directly attached to or part of the motherboard include:

- The **CPU** (Central Processing Unit), which performs most of the calculations which enable a computer to function, and is sometimes referred to as the brain of the computer. It is usually cooled by a heatsink and fan, or water-cooling system. Most newer CPUs include an on-die Graphics Processing Unit (GPU). The clock speed of CPUs governs how fast it executes instructions, and is measured in GHz; typical values lie between 1 GHz and 5 GHz. Many modern computers have the option to overclock the CPU which enhances performance at the expense of greater thermal output and thus a need for improved cooling.
- The **chipset**, which includes the north bridge, mediates communication between the CPU and the other components of the system, including main memory.
- **Random-Access Memory** (RAM), which stores the code and data that are being actively accessed by the CPU. RAM usually comes on DIMMs in the sizes 2GB, 4GB, and 8GB, but can be much larger.
- **Read-Only Memory** (ROM), which stores the BIOS that runs when the computer is powered on or otherwise begins execution, a process known as Bootstrapping, or “booting” or “booting up.” The **BIOS** (Basic Input Output System) includes boot firmware and power management firmware. Newer motherboards use Unified Extensible Firmware Interface (UEFI) instead of BIOS.
- **Buses** connect the CPU to various internal components and to expand cards for graphics and sound.
- The CMOS battery, which powers the memory for date and time in the BIOS chip. This battery is generally a watch battery.
- The **video card** (also known as the graphics card), which processes computer graphics. More powerful graphics cards are better suited to handle strenuous tasks, such as playing intensive video games.



### 15.5.3 Watches



#### Activity 15.9: Identifying the component of a digital watch

Take a digital wrist watch as in Fig. 15.11 and open it to see components inside on the motherboard. Discuss and explain functions of different components you have observed on the motherboard.



**A quartz watch** is a watch that uses an electronic oscillator that is regulated by a quartz crystal to keep time. An **electronic oscillator** is an electronic circuit that produces a periodic, oscillating electronic signal, often a sine wave or a square wave. They are widely used in many electronic devices.

**Fig. 15.11:** *Electronic digital watch*

Common examples of signals generated by oscillators include signals broadcast by radio and television transmitters, clock signals that regulate computers and quartz watches, and the sounds produced by electronic beepers. This crystal oscillator creates a signal with very precise frequency, so that quartz clocks are at least an order of magnitude more accurate than mechanical clocks.

#### Checking my progress

1. Circle the types of diodes from the list below.
  - (a) Zener
  - (b) P-n Junction
  - (c) Laser
  - (d) Photo
  - (e) LED
2. Transistors are used for ..... as resistors are used for .....  
Place these words appropriately in the spaces. (switching, storing energy, increasing current, reducing current, amplifying)

3. Capacitors are used to store electrical energy.
  - (a) True
  - (b) False
4. Why are many watches nowadays called electronic watches? (Choose the correct statement)
  - (a) They contain a circuit where current flows through semi-conductors.
  - (b) They use direct current flowing through their circuit.
  - (c) They use alternating current flowing through them.
  - (d) They operate the same way as a computer.

## 15.6 Working principle of basic electronic devices

*Principles of Electronics* presents a broad spectrum of topics, such as atomic structure, Kirchhoff's laws, energy, power, introductory circuit analysis techniques, Thevenin's theorem, the maximum power transfer theorem, electric circuit analysis, magnetism, resonance, control relays, relay logic, semi-conductor diodes, electron current flow, and much more. Smoothly integrate the flow of material in a non-mathematical format without sacrificing depth of coverage or accuracy to help readers grasp more complex concepts and gain a more thorough understanding of the principles of electronics. This includes many practical applications, problems and examples emphasising **troubleshooting, design, and safety to provide a solid foundation in the field of electronics.**

In general, troubleshooting is the identification of the diagnosis of "trouble" in the management flow of a corporation or a system caused by a failure of some kind. The problem is initially described as symptoms of malfunction; and troubleshooting is the process of determining and remedying the causes of these symptoms. A system can be described in terms of its expected, desired or intended behaviour (usually, for artificial systems, its purpose). Events or inputs to the system are expected to generate specific results or outputs. (For example selecting the "print" option from various computer applications is intended to result in a hardcopy emerging from some specific device). Any unexpected or undesirable behaviour is a symptom. Troubleshooting is the process of isolating the specific cause or causes of the symptom. Frequently the symptom is a failure of the product or process to produce any results (nothing was printed, for example). Corrective action can then be taken to prevent further failures of a similar kind.

## 15.7 Unit 15 assessment

1. A semi-conductor is formed by ..... bonds.
  - A. Covalent
  - B. Electrovalent
  - C. Co-ordinate
  - D. None of the above
2. A semi-conductor has ..... temperature coefficient of resistance.
  - A. Positive
  - B. Zero
  - C. Negative
  - D. None of the above
3. The most commonly used semi-conductor is .....
  - A. Germanium
  - B. Silicon
  - C. Carbon
  - D. Sulphur
4. A semi-conductor has generally ..... valence electrons.
  - A. 2
  - B. 3
  - C. 6
  - D. 4
5. When a pure semi-conductor is heated, its resistance .....
  - A. Goes up
  - B. Goes down
  - C. Remains the same
  - D. Can't say
6. Addition of pentavalent impurity to a semi-conductor creates many .....
  - A. Free electrons
  - B. Holes
  - C. Valence electrons
  - D. Bound electrons
7. A pentavalent impurity has ..... Valence electrons.
  - A. 3
  - B. 5
  - C. 4
  - D. 6
8. Addition of trivalent impurity to a semi-conductor creates many .....
  - E. Holes
  - F. Free electrons
  - G. Valence electrons
  - H. Bound electrons

9. A hole in a semi-conductor is defined as .....
  - A. A free electron
  - B. The incomplete part of an electron pair bond
  - C. A free proton
  - D. A free neutron
10. In a semi-conductor, current conduction is due to .....
  - A. Only holes
  - B. Only free electrons
  - C. Holes and free electrons
  - D. None of the above
11. What is the basis for classifying a material as a conductor, semi-conductor?
12. Differentiate semi-conductors, conductors and insulators on the basis of band gap.
13. Is a hole a fundamental particle in an atom?
14. Define a hole in a semi-conductor.
15. Why is it that silicon and germanium are the two widely used semi-conductor materials?
16. Which of the two semi-conductor materials Si or Ge has larger conductivity at room temperature? Why?
17. Why does a pure semi-conductor behave like an insulator at absolute zero temperature?
18. What is the main factor for controlling the thermal generation and recombination?
19. In which bands do the movement of electrons and holes take place?
20. Discuss the mechanism by which conduction takes place inside the semi-conductor?

## Hypertext book

---

1. <http://www.mkpublishers.com>
2. [http://en.wikibooks.org/w/index.php?title=Physics\\_Exercises/Kinematics](http://en.wikibooks.org/w/index.php?title=Physics_Exercises/Kinematics)
3. [http://en.wikipedia.org/wiki/Newton%27s\\_laws\\_of\\_motion](http://en.wikipedia.org/wiki/Newton%27s_laws_of_motion)
4. <http://fr.wikipedia.org/wiki/kinemarics>
5. <http://fr.wikipedia.org/wiki/phys#Recherche-d>
6. <http://pstc.aapt.org>
7. <http://www.answers.com/Topic/Physics>
8. <http://www.answers.com/topic/temperature-conversion>
9. <http://www.answers.com/Topic/Thermometer>
10. <http://www.glenbrook.k12.il.us/GBSSCI/PHYS/Class/newtlaws>
11. <Http://www.howstuffworks.com/pulley.htm>
12. [http://www.newworldencyclopedia.org/entry/Freezing\\_point](http://www.newworldencyclopedia.org/entry/Freezing_point)
13. <http://www.school-for-champions.com/science/matterstates>
14. [www.iop.org](http://www.iop.org)
15. [www.physicscentral.com](http://www.physicscentral.com)
16. [www.sciam.com](http://www.sciam.com)
17. [www.worldofteaching.com](http://www.worldofteaching.com)
18. <http://www.dynamicscience.com.au/tester/solutions1/chemistry/atomic%20structure/>
19. <https://www.boundless.com/physics/textbooks/boundless-physics-textbook>
20. <http://www.electronicandyou.com/index.html#sthash.ZoDTLzgP.dpuf>

# Bibliography

1. ABBOT A.F, JOHN COCKCROFT, 1989, *Physics*, Fifth Edition, Heinemann Educational Publishers.
2. Cunningham, William P, 2001, *Environmental science*, Mc Graw-Hill, 6<sup>th</sup> Ed.
3. HEWITT P.G, SUCHOCKI J., HEWITT L.A., 1999, *Conceptual Physical Science*, Second edition, Addison Wesley Longman
4. Holt, Rinehart and Winstone, 1999, *Physics*
5. MINEDUC, 2006, *Ordinary level science curriculum (Biology, Chemistry, Physics)*, NCDC, Kigali,
6. PATRICK T., 2004, *Mathematics standard level*, 3rd Edition, Ibid Press, Victoria,
7. SILVER Burdett, GINN Inc, 1990, *Physical Science*, United States of America,
8. WABWIRE S.H, KASIRYE S., 2007, *MK secondary Physics*, student's book 1, MK Publishers LTD, Kampala-Uganda.